

CR-H, CRE-H

Horizontal end-suction multistage centrifugal pumps
60 Hz



Contents

Product data

Introduction	4
Performance range - CR-H	5
Applications	6
Product range	7
Pump	8
Motor	8
Electrical data and approvals	8
Optional motors	8
Motor protection	8
Terminal box positions	9
Ambient temperature	9
Viscosity	9

Product data for E-pumps

Examples of E-pump applications	10
---------------------------------	----

Control of E-pumps

Control options of E-pumps	11
Control modes for E-pumps	11

Construction

CR 1s, 1, 3, 5, 10, 15 and 20 H	13
CR 32, 45, 64, and 90 H	13

Type key and codes

Type key	14
Codes	14

Operating and inlet pressure

Maximum operating pressure and temperature range	15
Operating range of the shaft seal	16
Maximum inlet pressure	17

Selection and sizing

Selection of pumps	18
Minimum inlet pressure - NPSHA	22

How to read the curve charts

Guidelines to the curve charts	23
CR 1s H	24

Curve charts/technical data

CR, CRE 1 H	26
CR, CRE 3 H	28
CR, CRE 5 H	30
CR, CRE 10 H G22	32
CR, CRE 10 H GA/G05	34

CR, CRE 15 H G22	37
CR, CRE 15 H GA/G05	39
CR, CRE 15 H GB	42
CR, CRE 20 H G22	44
CR, CRE 20 H GA/G05	46
CR, CRE 20 H GB	49
CR, CRE 32 H G22	51
CR, CRE 32 H GA/G05	53
CR, CRE 32 H GB/G50	56
CR, CRE 32 H GC/G10/G60	59
CR, CRE 45 H G33	63
CR, CRE 45 H GB/G20/G50	65
CR, CRE 45 H GC/G10/G30/G60	69
CR, CRE 64 H G44	74
CR, CRE 64 H GC/G10/G30/G60	76
CR, CRE 64 H G20/G50	81
CR, CRE 64 H G40/G70	84
CR 90 H G44	87
CR 90 H G20	89
CR 90 H G30/G60	91
CR 90 H G40/G70	94

Motor data

Motors for CR-H, CRE-H pumps	97
------------------------------	----

Pumped liquids

Pumped liquids	100
List of pumped liquids	100

Accessories

Grundfos CR-H baseplate	102
Baseplate selection	103
Baseplate dimensions and weight	104
Pipework connection	106
Sensors for CRE-H	107
Gauges for CR-H, CRE-H	107
MP 204 motor protector	108

Submittal data sheet

Submittal data	109
----------------	-----

Quotation text

CR-H, CRE-H	110
-------------	-----

Further product documentation

WebCAPS	111
WinCAPS	112

- It is our mission - the basis of our existence - to successfully develop, produce and sell high-quality pumps and pumping systems world-wide, contributing to a better quality of life and a healthy environment



Bjerringbro, Denmark



Fresno, California



Olathe, Kansas



Monterrey, Mexico



Allentown, Pennsylvania



Oakville, Ontario

- One of the 3 largest pump companies in the world
- The second largest manufacturer of submersible motors in the world
- World headquarters in Denmark
- North American headquarters in Kansas City - Manufacturing in Fresno, California
- 80 companies in 45 countries
- More than 16 million motors and pumps produced annually worldwide
- North American companies operating in USA, Canada and Mexico
- Continuous reinvestment in growth and development enables the company to **BE** responsible, **THINK** ahead, and **INNOVATE**

Introduction

This data booklet deals with CR-H horizontal end suction pumps as well as CRE-H pumps.

CR-H



TM04 3882

Fig. 1 CR-H pumps

CR-H pumps are horizontal end suction pumps typically mounted on baseplates. The end suction design enables the pump to be installed horizontally in traditional, end suction design piping where the pump has an axial suction port and a radial center line discharge port. This design allows “back pull-out” capability. This means the pump usually can be easily serviced without removing the volute from the pipe system.

Grundfos CR-H pumps come with various pump sizes and various numbers of stages to provide the flow and the pressure required.

CR-H pumps are suitable for a variety of applications from pumping of potable water to pumping of chemicals. The pumps are therefore used in a wide variety of pumping systems where the performance and material of the pump meet specific demands.

The CR-H pumps consist of three main components: the motor, the pump unit, and the baseplate.

The pump unit consists of optimized hydraulics, various flange connections, a pump head, and an end suction volute.

CR-H pumps are available in various material versions according to the pumped liquid.

CR-H pumps can be selected that meet ASME B73.1 dimensional standards for suction and discharge piping as well as many of the baseplate dimensional standards. **CR-H pumps do not fully comply with the ASME B73.1 specification.** There is also a full range of CR-H pumps with standard Grundfos connection sizes that are optimized to give greater performance and efficiency.

CRE-H



TM04-4177 0909

Fig. 1 CRE-H pumps

CRE-H pumps are built on the basis of CR-H pumps. CRE-H pumps belong to the so-called E-pump family and are referred to as E-pumps.

The difference between the CR-H and the CRE-H pump range is the motor. CRE-H pumps are fitted with an E-motor with built-in frequency control.

The CRE-H pump has a Grundfos MLE motor.

Frequency control enables continuously variable control of motor speed, which makes it possible to set the pump to operation at any duty point. The aim of continuously variable control of the motor speed is to adjust the performance to a given requirement.

CRE-H pumps are available with an attached pressure sensor connected to a frequency control.

The pump materials are the same as those of the CR-H.

Selecting a CRE-H pump

Select a CRE-H pump if:

- controlled operation is required, i.e. consumption fluctuates.
- constant pressure is required.
- communication with the pump is required.

Adaptation of performance through frequency-controlled speed control offers obvious advantages:

- energy savings
- increased comfort
- control and monitoring of the pump performance.

See pages 10 - 12 for more information about E-pumps.

Performance range - CR-H

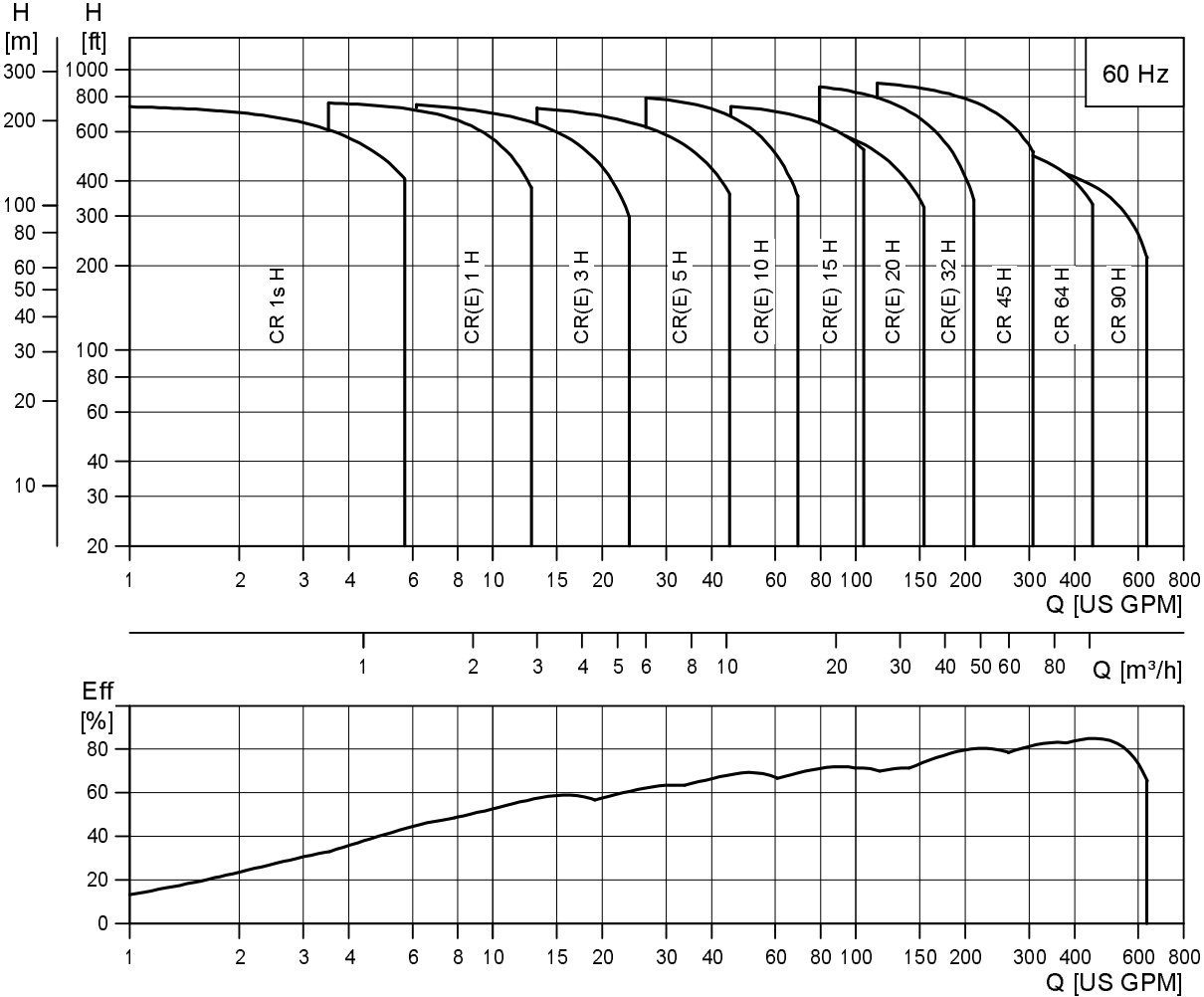

TM04-4552-1609

Applications

Application	CR-H	CRE-H
Water supply		
Filtration and transfer at waterworks	●	●
Distribution from waterworks	●	●
Pressure boosting in mains	●	●
Pressure boosting in high-rise buildings, hotels, etc.	●	●
Pressure boosting for industrial water supply	●	●
Industry		
Pressure boosting in...		
process water systems	●	●
washing and cleaning systems	●	○
vehicle washing tunnels	●	●
fire fighting systems	●	
Liquid transfer in...		
cooling and air-conditioning systems (refrigerants)	●	●
boiler feed and condensate systems	●	●
machine tools (cooling lubricants)	●	●
aquafarming	●	
Transfer of...		
oils and alcohols	●	●
glycol and coolants	●	●
Water treatment		
Separators	●	●
Irrigation		
Field irrigation (flooding)	●	
Sprinkler irrigation	●	●
Drip-feed irrigation	●	

● Recommended version.

○ Alternative version.

Product range

Range	CR, CRE 1s H	CR, CRE 1 H	CR, CRE 3 H	CR, CRE 5 H	CR, CRE 10 H	CR, CRE 15 H	CR, CRE 20 H	CR, CRE 32 H	CR, CRE 45 H	CR, CRE 64 H	CR, CRE 90 H	
Nominal flow rate [US GPM]	4.5	8.5	15	30	55	95	110	140	220	340	440	
Temperature range [°F]						-4 to +250		-22 to +250				
Temperature range [°F] — on request						-40 to +356		-40 to +356				
Max. working pressure [psi]	360	360	360	360	360	360	360	435	435	435	435	
Max. pump efficiency [%]	35	49	59	64	70	72	72	73	80	82	85	
CR-H pumps												
CR: Flow range [US GPM]	0.5 - 5.7	1 - 12.8	1.5 - 23.8	3 - 45	5.5 - 70	9.5 - 125	11 - 155	14 - 210	22 - 310	34 - 450	44 - 630	
CR: Max. pump pressure (H[ft])	745	785	785	780	810	760	675	935	930	590	570	
CR: Motor power [Hp]	0.33 - 2.0	0.33 - 3.0	0.33 - 5.0	0.75 - 7.5	0.75 - 15	2.0 - 25	3.0 - 25	3.0 - 40	7.5 - 60	7.5 - 60	15 - 60	
CRE-H pumps												
CRE: Flow range [US GPM]	0 - 5.7	0 - 12.8	0 - 23.8	0 - 45	0 - 70	0 - 125	0 - 155	0 - 210	0 - 310	0 - 450	-	
CRE: Max. pump pressure (H[ft])	745	785	785	780	670	385	270	225	120	100	-	
CRE: Motor power [Hp]	0.33 - 2.0	0.33 - 3.0	0.33 - 5.0	0.75 - 7.5	0.75 - 10	2.0 - 10	3.0 - 10	3.0 - 10	7.5	7.5	-	
Version												
CR-H, CRE-H: Cast iron and stainless steel AISI 304	•	•	•	•	•	•	•	•	•	•	•	
CR-H, CRE-H pipe connection												
ANSI connection type	GA	GA	GA	GA	G22*	G22*	G22*	G22*	G33*	G44*	G44*	
ANSI flange class [lb]	125/ 250	125/ 250	125/ 250	125/ 250	125/ 250	125/ 250	125/ 250	125/ 250	125/ 250	125/ 250	125/ 250	
Pipe connection - inlet x discharge x impeller size reference												
GA	ANSI 1.5" x 1" x 6", 1.5" x 1" x 8"	•	•	•	•	•	•	•	•			
G05	ANSI 2" x 1" x 10"				•	•	•	•				
GB	ANSI 3" x 1.5" x 6", 3" x 1.5" x 8"					•	•	•	•			
GC	ANSI 3" x 2" x 6"							•	•	•		
G10	ANSI 3" x 2" x 6"							•	•	•		
G50	ANSI 3" x 1.5" x 8", 3" x 1.5" x 10"							•	•	•		
G60	ANSI 3" x 2" x 8", 3" x 2" x 10"							•	•	•	•	
G20	ANSI 3" x 1.5" x 13"								•	•	•	
G30	ANSI 3" x 2" x 13"								•	•	•	
G70	ANSI 4" x 3" x 8", 4" x 3" x 10"									•	•	
G40	ANSI 4" x 3" x 10", 4" x 3" x 13"									•	•	
G22	ANSI 2" x 2"				•	•	•	•				
G33	ANSI 3" x 3"							•	•			
G44	ANSI 4" x 4"									•	•	

• Available

* There are a variety of flange size options available for this size CR-H (see list below). Selection should be based on replacement size or choose listed size for new installations.

Pump

The CR-H pump is a non-self-priming, horizontal, end suction, multistage centrifugal pump with enclosed impellers. The pumps are available with a Grundfos standard motor (CR-H pumps) or a frequency-controlled motor (CRE-H pumps).

The pump consists of a volute and a pump head. The chamber stack and the outer sleeve are secured between the pump head and the volute by means of staybolts. The volute has an end suction port and vertical centerline discharge port.

All pumps are equipped with a maintenance-free mechanical shaft seal of the cartridge type.

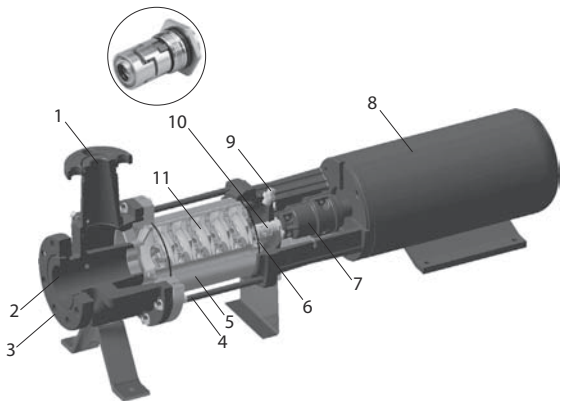

Fig. 2 CR-H pump

CR-H components

Pos.	Designation	Pos.	Designation
1	Discharge	7	Coupling
2	Suction	8	Motor
3	Flange	9	Priming plug
4	Staybolts	10	Shaft seal
5	Outer sleeve	11	Impellers
6	O-ring		

Motor

Grundfos standard motors - ML and Baldor® motors

CR-H pumps are fitted with a Grundfos specified motor. The motors are all heavy-duty 2-pole, NEMA C-face motors. Three-phase motors greater than .75 hp are energy efficient at minimum.

Frequency-controlled motors - MLE motors

CRE-H pumps are fitted with a totally enclosed, fan-cooled, 2-pole frequency-controlled motor with integrated variable frequency drive.

From 0.5 Hp to 1.5 Hp Grundfos offers pumps fitted with single-phase MLE motors (1 x 208-230 V). From 1.0 Hp to 10 Hp Grundfos offers pumps fitted with three-phase MLE motors (3 x 460-480 V). From 1.5 Hp to 7.5 Hp Grundfos offers pumps fitted with three-phase MLE motors (3 x 208-230 V).

Electrical data and approvals

Mounting designation	NEMA
Insulation class	F & B
Efficiency class*	Standard efficiency - single phase Energy efficient / EPC - three phase Baldor motors Premium efficiency - three phase ML motors (>.75 hp)
Enclosure class	TEFC - Totally Enclosed Fan Cooled (Grundfos standard) ODP - Open Drip Proof - on request
60 Hz Standard voltages	1 x 115/208-230 V 3 x 208-230/460 V 3 x 575 V

Approvals  Baldor  ML/MLE  

* Premium efficiency three phase Baldor motors - on request.

Optional motors

The Grundfos standard range of motors covers a wide variety of application demands. However, for special applications or operating conditions, custom-built motor solutions can be provided.

For special applications or operating conditions, Grundfos offers custom-built motors such as:

- explosion proof motors
- motors with anti-condensation heating unit
- low-noise motors
- energy efficient and premium efficiency motors
- motors with thermal protection.

Motor protection

Single-phase Grundfos specified motors up to 7.5 hp have a built-in thermal overload switch.

Three-phase motors **must** be connected to a motor starter in accordance with local regulations.

Terminal box positions

As standard the terminal box is mounted as shown in fig. 3.

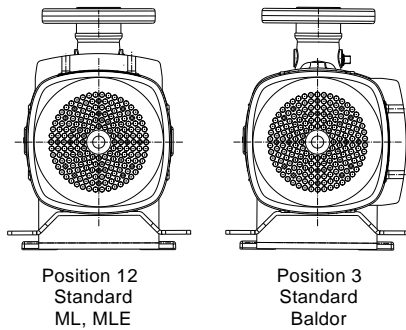

Fig. 3 Terminal box positions

TM02 18 05 2001

Ambient temperature

If the ambient temperature exceeds the maximum temperature limits of the motor or the pump is installed at an altitude exceeding the altitude values in the chart below, the motor must not be fully loaded due to the risk of overheating.

Overheating may result from excessive ambient temperatures or the low density and consequently low cooling effect of the air at high altitudes. In such cases, it may be necessary to use a motor with a higher rated output (P_2).

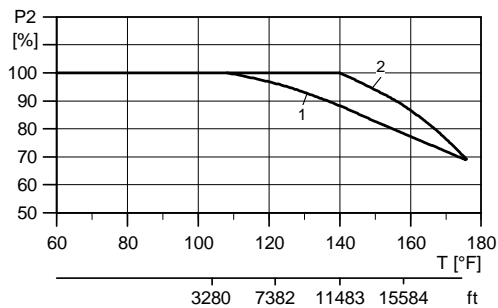

Fig. 4 Relationship between motor output (P_2) and ambient temperature/altitude

TM03 4272 2006

Example: From fig. 4 it appears that P_2 must be reduced to 88 % when a pump with a NEMA Premium efficiency, ML motor is installed 15,584 feet above sea level. At an ambient temperature of 167 °F, P_2 of a standard efficiency motor must be reduced to 74 % of rated output.

Viscosity

The pumping of liquids with densities or kinematic viscosities higher than those of water will cause a considerable pressure drop, a drop in the hydraulic performance and a rise in the power consumption.

In such situations the pump should be equipped with a larger motor. For selection you may utilize Grundfos WinCAPS/WebCAPS. If in doubt, contact Grundfos.

Legend

Pos.	Description
1	NEMA energy efficient motors (EPAct)
2	NEMA Premium efficiency motors

Examples of E-pump applications

CRE-H pumps are the ideal solution in a number of applications characterized by a need for variable flow at constant pressure. The pumps are suited for water supply systems and pressure boosting, but also industrial applications.

Depending on the nature of the application, the pumps offer energy-savings, increased comfort or improved processing.

E-pumps in the service of industry

Industry uses a large number of pumps in many different applications. Demands on pumps in terms of pump performance and mode of operation make speed control a must in many applications.

Below are mentioned some of the applications in which E-pumps are often used.

Constant pressure

- Water supply
- washing and cleaning systems
- distribution from waterworks
- humidifying systems
- water treatment systems
- process boosting systems, etc.

Example: Within industrial water supply, E-pumps with integrated pressure sensors are used to ensure a constant pressure in the piping network. From the sensor, the E-pump receives inputs about changes of pressure as a result of changes in the consumption. The E-pump responds to the input by adjusting the flow until the pressure is equalized. As a result, the constant pressure is stabilized once more on the basis of a preset setpoint.

Constant temperature

- Air-conditioning systems at industrial plants
- industrial cooling systems
- industrial freezing systems
- casting and molding tools, etc.

Example: In industrial freezing systems, E-pumps with temperature sensors increase comfort and lower operating costs compared with pumps without temperature sensors.

An E-pump continuously adapts its performance to the changing demands reflected in the differences in temperature of the liquid circulating in the freezing system. Thus, the lower the demand for cooling, the smaller the quantity of liquid circulated in the system and vice versa.

Constant flow or level

- Steam boiler systems
- condensate systems
- sprinkler irrigation systems
- chemical industry, etc.

Example: In a steam boiler, it is important to be able to monitor and control pump operation to maintain a constant level of water in the boiler.

By using an E-pump with level sensor mounted in the boiler, it is possible to maintain a constant water level. A constant water level ensures optimum and cost-efficient operation as a result of a stable steam production.

Dosing

- Chemical industry (i.e. control of pH-values)
- petrochemical industry
- degreasing systems
- bleaching systems, etc.

Example: In the petrochemical industry, E-pumps with pressure sensors are used as dosing pumps. The E-pumps help to ensure that the correct mixture ratio is achieved when more liquids are combined.

E-pumps functioning as dosing pumps improve processing and offer energy-savings.

E-pumps in commercial building services

Commercial building services use E-pumps to maintain a constant pressure or a constant temperature based on a variable flow.

E-pumps are used in applications such as:

Constant pressure

- Water supply in high-rise buildings i.e. office buildings, hotels, etc.

Example: E-pumps with pressure sensors are used for water supply in high-rise buildings to ensure a constant pressure even at the highest draw-off point. As the consumption pattern and thus the pressure changes during the day, the E-pump continuously adapts its performance until the pressure is equalized.

Constant temperature

- Air-conditioning systems in hotels, schools, etc.
- building cooling systems, etc.

Example: E-pumps are an excellent solution in buildings where constant temperature is essential. E-pumps keep the temperature constant in air-conditioned, high-rise glass buildings, irrespective of the seasonal fluctuations of the out-door temperature and various heat impacts inside the building.

Control options of E-pumps

Communication with CRE-H pumps is possible by means of the following interfaces:

- a central management system
- remote control (Grundfos R100) or
- a control panel.

The purpose of controlling an E-pump is to monitor and control the pressure, temperature, flow and liquid level of the system.

Central management system

Communication with the E-pump is possible even though the operator is not present near the E-pump. Communication is enabled by having the E-pump connected to a central management system allowing the operator to monitor and change control modes and setpoint settings of the E-pump.

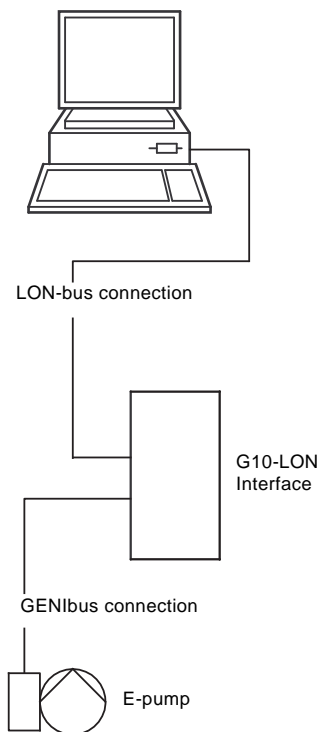

Fig. 5 Structure of a central management system

TM02 6592 1103

Remote control

The R100 remote control produced by Grundfos is available as an accessory.

The operator communicates with the E-pump by pointing the IR-signal transmitter at the control panel of the E-pump terminal box.

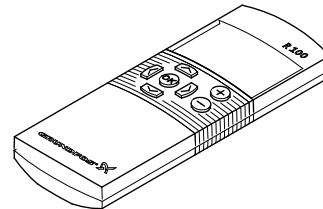

TM00 4498 2802

Fig. 6 R100 remote control

The R100 enables monitoring and changing of control modes and settings of the E-pump.

Control panel

The control panel of the E-pump terminal box makes it possible to change the setpoint settings manually.

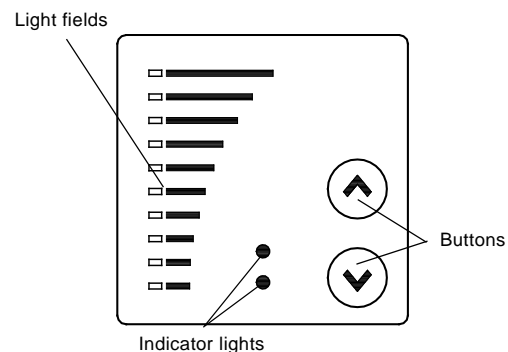

TM00 7600 1196

Fig. 7 Control panel on CRE-H pump

Control modes for E-pumps

Grundfos offers CRE-H pumps in two different variants:

- CRE-H with integrated pressure sensor
- CRE-H without sensor.

CR-H with integrated pressure sensor

CRE-H pumps with integrated pressure sensor are suitable for applications where you want to control the pressure after the pump, irrespective of the flow. See the section *Examples of E-pump applications* on page 10 for further information.

Signals of pressure changes in the piping system are transmitted continuously from the sensor to the pump.

The pump responds to the signals by adjusting its performance up or down to compensate for the pressure difference between the actual and the desired pressure. As this adjustment is a continuous process, a constant pressure is maintained in the piping system.



Fig. 8 CRE-H pump

A CRE-H pump with integrated pressure sensor facilitates installation and commissioning. CRE-H pumps with integrated pressure sensor can be set to:

- constant-pressure mode (factory setting) or
- constant-curve mode.

In **constant-pressure** mode, the pump maintains a preset pressure after the pump, irrespective of the flow. See fig. 9.

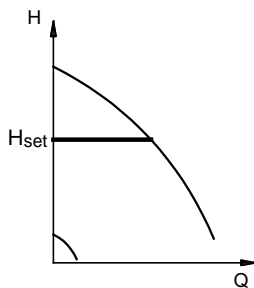

Fig. 9 Constant pressure mode

In **constant-curve** mode, the pump is not controlled. It can be set to pump according to a preset pump characteristic within the range from min. curve to max. curve. See fig. 10.

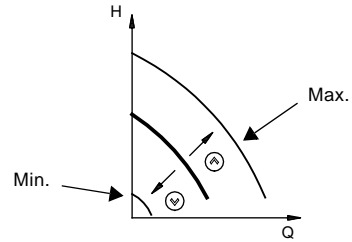

Fig. 10 Constant curve mode

CRE-H without sensor

CRE-H pumps without sensors are suitable for applications where:

- uncontrolled operation is required
- you want to fit another sensor later in order to control the flow, temperature, differential temperature, liquid level, pH value, etc at some arbitrary point in the system.

CRE-H pumps without sensor can be set to:

- controlled-operation mode or
- uncontrolled-operation mode (factory-setting).

In **controlled**-operation mode, the pump adjusts its performance to the desired setpoint. See fig. 11.

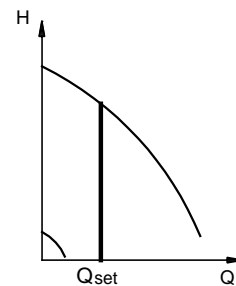

Fig. 11 Constant flow mode

In **uncontrolled**-operation mode, the pump operates according to the constant curve set. See fig. 12.

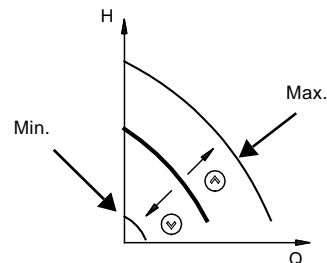

Fig. 12 Constant curve mode

CRE-H pumps can be fitted with sensor types listed on page 107.

TM04 4177 0909

TM00 9322 4796

TM00 9323 4796

TM02 7264 2803

TM00 9323 4796

CR 1s, 1, 3, 5, 10, 15 and 20 H



TM04 4524 1509

Fig. 13 Product photo

CR 32, 45, 64, and 90 H



TM04 4525 1509

Fig. 15 Product photo

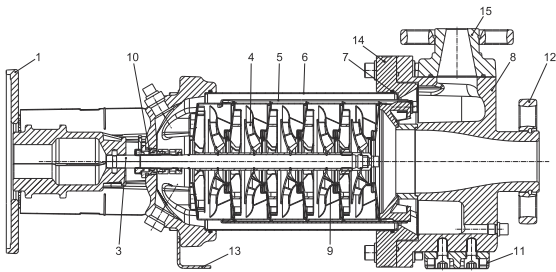

TM04 4269 1009

Fig. 14 Sectional drawing

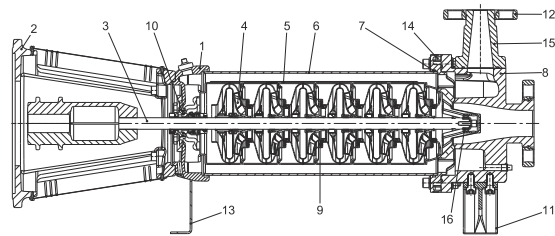

TM04 4270 1009

Fig. 16 Sectional drawing

Materials: CR-H

Pos.	Designation	Materials	AISI/ASTM
1	Pump head	Cast iron	A 48-30 B
3	Shaft	Stainless steel	AISI 316 ¹⁾ AISI 431 ²⁾
4	Impeller	Stainless steel	AISI 304
5	Chamber	Stainless steel	AISI 304
6	Outer sleeve	Stainless steel	AISI 304
7	O-ring for outer sleeve	EPDM or FKM	
8	Suction-discharge housing	Ductile iron	A 80-55-06
9	Neck ring	PTFE	
10	Shaft seal	Cartridge type	
	Bearing rings	Silicon carbide	
	Rubber parts	EPDM or FKM	
11	Foot	Ductile iron	A 80-55-06
12	Flange	Ductile iron ³⁾	A 80-55-06
13	Support bracket	Stainless steel	AISI 304
14	Sleeve flange ⁵⁾	Stainless steel	CF 8M ⁴⁾
15	Discharge port	Ductile iron	A 80-55-06

¹⁾ CR-H, CRE-H 1s, 1, 3, 5

²⁾ CR-H, CRE-H 10, 15, 20

³⁾ Stainless steel available on request (not all sizes).

⁴⁾ CF 8M is cast equivalent of AISI 316 stainless steel.

⁵⁾ CR-H, CRE-H 10, 15, 20 only; CR-H, CRE-H 1s, 1, 3, 5 do not have a sleeve flange.

Materials: CR(E)-H

Pos.	Designation	Materials	AISI/ASTM
1	Pump head	Ductile iron	A 80-55-06
2	Motor stool	Cast iron	A 48-30 B
3	Shaft	Stainless steel	AISI 431
4	Impeller	Stainless steel	AISI 304
5	Chamber	Stainless steel	AISI 304
6	Outer sleeve	Stainless steel	AISI 304
7	O-ring for outer sleeve	EPDM or FKM	
8	Suction-discharge housing	Ductile iron	A 80-55-06
9	Neck ring	Acoflon 215	
10	Shaft seal	Cartridge type	
	Bearing ring	Bronze	
11	Foot	Ductile iron	A 80-55-06
	Rubber parts	EPDM or FKM	
12	Flange	Ductile iron ³⁾	A 80-55-06
13	Support bracket	Stainless steel	AISI 304
14	Sleeve flange	Stainless steel	CF 8M ⁴⁾
15	Discharge port	Ductile iron	A 80-55-06
16	Bottom bearing ring	Tungsten carbide/ Tungsten carbide	

Type key

CR-H, CRE-H

Example	CR	E	5	s	-4	-2	H	-GA	-G	-E	HQQE
Type range											
Pump with integrated frequency control											
Rated flow rate [m ³ /h]											
All impellers with reduced diameter (applies only to CR, CRE 1s H)											
Number of impellers											
Number of reduced diameter impellers (applies only to CR, CRE 32, 45, 64, 90 H)											
Code for pump version											
Code for pipe connection											
Code for materials											
Code for rubber parts											
Code for shaft seal											

Codes

Example	H	-GA	-A	-E	-H	QQ	E
Pump version							
A Basic version ¹⁾							
B Oversize motor							
E Certificate/approval							
F CR pump for high temperatures (air cooled top assembly)							
H Horizontal version							
I Different pressure rating							
J Pump with different max speed							
K Pump with low NPSH							
N Fitted with sensor							
P Undersize motor							
T Over size motor							
X Special version ¹⁾							

Example	H	-GA	-A	-E	-H	QQ	E
Pipe connection (inlet x discharge x impeller size reference)²⁾							
GA ANSI 1.5" x 1" x 6", 1.5" x 1" x 8"							
G05 ANSI 2" x 1" x 10"							
GB ANSI 3" x 1.5" x 6", 3" x 1.5" x 8"							
GC ANSI 3" x 2" x 6"							
G10 ANSI 3" x 2" x 6"							
G50 ANSI 3" x 1.5" x 8", 3" x 1.5" x 10"							
G60 ANSI 3" x 2" x 8", 3" x 2" x 10"							
G20 ANSI 3" x 1.5" x 13"							
G30 ANSI 3" x 2" x 13"							
G70 ANSI 4" x 3" x 8", 4" x 3" x 10"							
G40 ANSI 4" x 3" x 10", 4" x 3" x 13"							
G22 ANSI 2" x 2"							
G33 ANSI 3" x 3"							
G44 ANSI 4" x 4"							
Materials							
A Basic version							
D Carbon-graphite filled PTFE (bearings)							
K Bronze (bearings)							
S SiC bearings + PTFE neck rings							
X Special version							
Code for rubber parts							
E EPDM							
F FXM							
K FFKM							
V FKM							
Shaft seal							
H Balanced cartridge seal with O-ring							
K Metal bellows cartridge seal							
O Double seal, back-to-back							
P Double seal, tandem							
X Special version							
B Carbon, synthetic resin-impregnated							
H Cemented tungsten carbide, embedded (hybrid)							
Q Silicon carbide							
U Cemented tungsten carbide							
X Other ceramics							
E EPDM							
F FXM							
K FFKM							
V FKM							

¹⁾ If a pump incorporates more than two pump versions, the code for the pump version is X. X also indicates special pump versions not listed above.

²⁾ The pipe connection code designates the pump as a **CR horizontal end-suction** pump.

Maximum operating pressure and temperature range

ANSI flanged

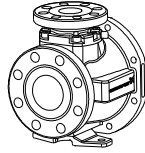

TM04 4039 0609

Pump type	Operating pressure	Liquid temperature range
CR(E) 1s-2 H → 1s-17 H	232 psi (16 bar)*	(-4°F to +248°F) (-20°C to +120°C)
CR(E) 1s-19 H → 1s-27 H	362 psi (25 bar)	
CR(E) 1-2 H → 1-17 H	232 psi (16 bar)*	
CR(E) 1-19 H → 1-27 H	362 psi (25 bar)	
CR(E) 3-2 H → 3-15 H	232 psi (16 bar)*	
CR(E) 3-17 H → 3-25 H	362 psi (25 bar)	
CR(E) 5-2 H → 5-15 H	232 psi (16 bar)*	
CR(E) 5-16 H → 5-24 H	362 psi (25 bar)	
CR(E) 10-1 H → 10-10 H	232 psi (16 bar)*	
CR(E) 10-12 H → 10-17 H	362 psi (25 bar)	
CR(E) 15-1 H → 15-8 H	232 psi (16 bar)*	
CR 15-9 H → 15-12 H	362 psi (25 bar)	
CR(E) 20-1 H → 20-7 H	232 psi (16 bar)*	
CR 20-8 H → 20-10 H	362 psi (25 bar)	
CR(E) 32-1-1 H → 32-5 H	232 psi (16 bar)*	(-22°F to +248°F) (-30°C to +120°C)
CR 32-6-2 H → 32-11-2 H	435 psi (30 bar)	
CR(E) 45-1-1 H → 45-4 H	232 psi (16 bar)*	
CR 45-5-2 H → 45-8-1 H	435 psi (30 bar)	
CR(E) 64-1-1 H → 64-3 H	232 psi (16 bar)*	
CR 64-4-2 H → 64-5-2 H	435 psi (30 bar)	
CR 90-1-1 H → 90-3 H	232 psi (16 bar)*	
CR 90-4-2 H → 90-4-1 H	435 psi (30 bar)	

* These pumps come standard with 125 lb. ANSI flanges.
High pressure versions are available which will raise the operating pressure to the next rating.

Operating range of the shaft seal

The operating range of the shaft seal depends on operating pressure, pump type, type of shaft seal and liquid temperature. The following curves apply to clean water and water with anti-freeze liquids. For selecting the right shaft seal, see *List of pumped liquids* on page 100.

CR 1s H to CR 20 H

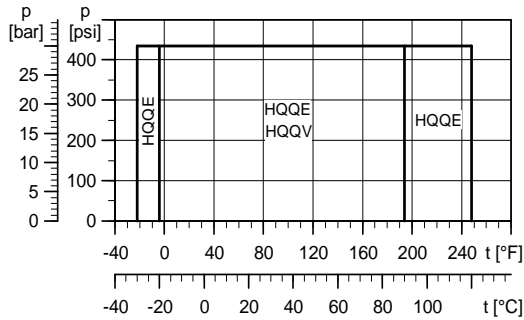

Fig. 17 Operating range of standard shaft seals for CR 1s H to CR 20 H

CR 32 H to CR 90 H

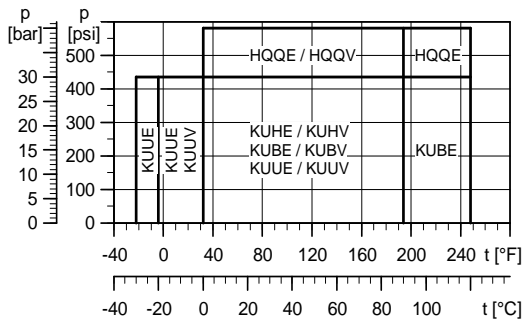

Fig. 18 Operating range of standard shaft seals for CR 32 H to CR 90 H

Shaft seal	Description	Max. temperature range [°F (C°)]
HQQE	O-ring (balanced cartridge seal), SiC/SiC, EPDM	- 22 °F to + 248 °F (- 30 °C to + 120 °C)
HQQV	O-ring (balanced cartridge seal), SiC/SiC, FKM	- 4 °F to + 194 °F (- 30 °C to + 90 °C)
HUBE	O-ring (balanced cartridge seal), TC/carbon, EPDM	+ 32 °F to + 248 °F (0 °C to + 120 °C)
HUBV	O-ring (balanced cartridge seal), TC/carbon, FKM	+ 32 °F to + 194 °F (0 °C to + 90 °C)
KUBE	Metal bellows (balanced cartridge seal), TC/carbon, EPDM	+ 32 °F to + 248 °F (0 °C to + 120 °C)
KUBV	Metal bellows (balanced cartridge seal), TC/carbon, FKM	+ 32 °F to + 194 °F (0 °C to + 90 °C)
KUHE	Metal bellows (balanced cartridge seal), TC/carbon with embedded TC, EPDM	+ 32 °F to + 194 °F (0 °C to + 90 °C)
KUHV	Metal bellows (balanced cartridge seal), TC/carbon with embedded TC, FKM	+ 32 °F to + 194 °F (0 °C to + 90 °C)
KUUE	Metal bellows (balanced cartridge seal), TC/TC, EPDM	- 22 °F to + 194 °F (-30 °C to + 90 °C)
KUUV	Metal bellows (balanced cartridge seal), TC/TC, FKM	- 4 °F to + 194 °F (- 30 °C to + 90 °C)

TC = tungsten carbide.

The pumping of liquids above 248 °F (120 °C) may result in periodical noise and reduced pump life. CR-H pumps are not suitable for the pumping of liquids above 248 °F (120 °C) for long periods.

Maximum inlet pressure

The following table shows the maximum permissible inlet pressure. However, the current inlet pressure + the pressure against closed valve **must** always be lower than the maximum permissible operating pressure.

If the maximum permissible operating pressure is exceeded, the bearing in the motor may be damaged and the life of the shaft seal reduced.

Max. inlet pressure CR-H	
CR 1s H	
CR 1s-2 H → CR 1s-27 H	145 psi (10 bar)
CR 1 H	
CR 1-2 H → CR 1-25 H	145 psi (10 bar)
CR 1-27 H	217 psi (15 bar)
CR 3 H	
CR 3-2 H → CR 3-15 H	145 psi (10 bar)
CR 3-17 H → CR 3-25 H	217 psi (15 bar)
CR 5 H	
CR 5-2 H → CR 5-9 H	145 psi (10 bar)
CR 5-10 H → CR 5-24 H	217 psi (15 bar)
CR 10 H	
CR 10-1 H → CR 10-5 H	116 psi (8 bar)
CR 10-6 H → CR 10-17 H	145 psi (10 bar)
CR 15 H	
CR 15-1 H → CR 15-2 H	116 psi (8 bar)
CR 15-3 H → CR 15-12 H	145 psi (10 bar)
CR 20 H	
CR 20-1 H	116 psi (8 bar)
CR 20-2 H → CR 20-10 H	145 psi (10 bar)
CR 32 H	
CR 32-1-1 H → CR 32-2 H	58 psi (4 bar)
CR 32-3-2 H → CR 32-6 H	145 psi (10 bar)
CR 32-7-2 H → CR 32-11-2 H	217 psi (15 bar)
CR 45 H	
CR 45-1-1 H → CR 45-1 H	58 psi (4 bar)
CR 45-2-2 H → CR 45-3 H	145 psi (10 bar)
CR 45-4-2 H → CR 45-8-1 H	217 psi (15 bar)
CR 64 H	
CR 64-1-1 H	58 psi (4 bar)
CR 64-1 H → CR 64-2-1 H	145 psi (10 bar)
CR 64-2 H → CR 64-5-2 H	217 psi (15 bar)
CR 90 H	
CR 90-1-1 H → CR 90-2-2 H	145 psi (10 bar)
CR 90-2-1 H → CR 90-4-1 H	217 psi (15 bar)

Example of operating and inlet pressures

The values for operating and inlet pressures shown in the tables must not be considered individually but must always be compared; see the following examples:

Example 1:

The following pump type has been selected:
CR 5-20 H-GA-A-E

Max. operating pressure: **362 psi (25 bar)**

Max. inlet pressure: **217 psi (15 bar)**

Discharge pressure against closed valve:

282 psi (652 ft). See page 30.

This pump is not allowed to start at an inlet pressure of 217 psi, but at an inlet pressure of:

$362 - 282 = 80 \text{ psi (5.5 bar)}$.

Example 2:

The following pump has been selected:

CR 10-2 H-G05-A-E

Max. operating pressure: **232 psi (16 bar)**

Max. inlet pressure: **116 psi (8 bar)**

Discharge pressure against closed valve:

42 psi (97 ft). See page 32.

This pump is allowed to start at an inlet pressure of 116 psi (8 bar), as the discharge pressure is only 42 psi (2.9 bar), which results in an operating pressure of $116 + 42 = 158 \text{ psi (11 bar)}$. On the contrary, the max. operating pressure of this pump is limited to 158 psi (11 bar), as a higher operating pressure will require an inlet pressure of more than 116 psi (77 bar).

Selection of pumps

Selection of pumps should be based on:

- duty point of the pump
- sizing data such as pressure loss as a result of height differences, friction loss in the pipework, pump efficiency etc.
- pump materials
- piping dimensions
- shaft seal
- inlet pressure and operating pressure.

1. Duty point of the pump

From a duty point it is possible to select a pump on the basis of the curve charts in the section *Curve charts/ technical data* starting on page 26.

- NPSH value.

For calculation of the NPSH value, see *Minimum inlet pressure - NPSHA* on page 22.

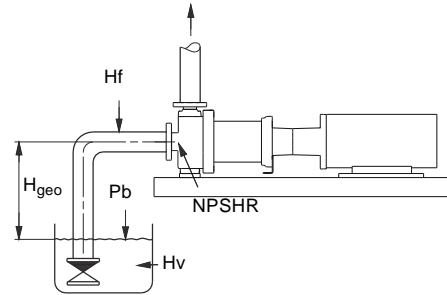
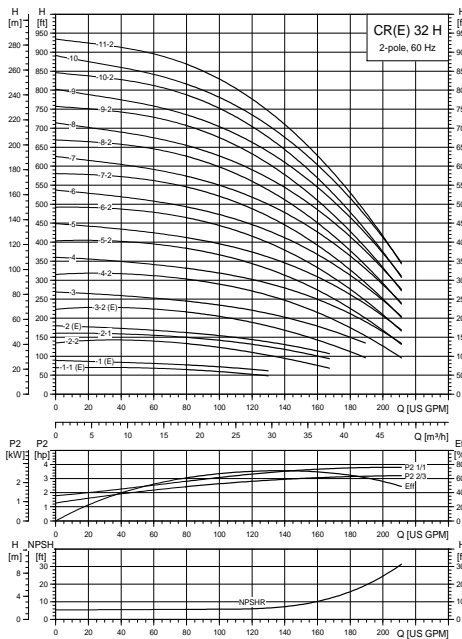

Fig. 20 Sizing data

TM04 3689 4804

Efficiency

Before determining the point of best efficiency, the operating pattern of the pump must be identified. If the pump is expected to operate in the same duty point, then select a CR pump which is operating in a duty point corresponding to the best efficiency of the pump.



TM04 4551 1609

Fig. 19 Example of a curve chart

2. Sizing data

When sizing a pump the following must be taken into account.

- Required flow and pressure at the point of use.
- Pressure loss as a result of height differences (H_{geo}).
- Friction loss in the pipework (H_f).
It may be necessary to account for pressure loss in connection with long pipes, bends or valves, etc.
- Best efficiency at the estimated duty point.

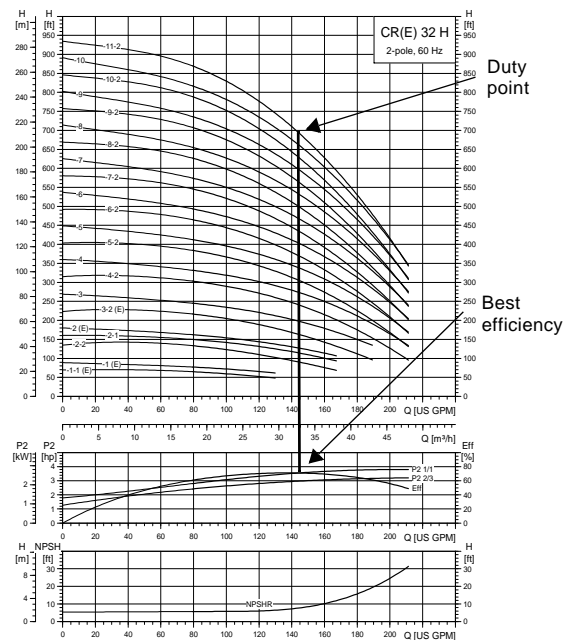

TM02 0039 1303

Fig. 21 Example of a CR pump's duty point

As the pump is sized on the basis of the highest possible flow, it is important to always have the duty point to the right of the optimum efficiency point (see fig. 22, range with check mark). This must be considered in order to keep efficiency high when the flow drops.

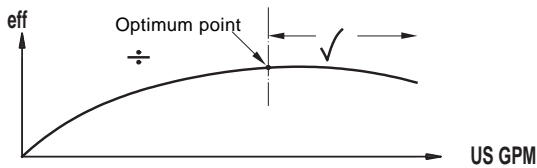

Fig. 22 Best efficiency

Normally, E-pumps are used in applications characterized by a variable flow. Consequently, it is not possible to select a pump that is constantly operating at optimum efficiency.

In order to achieve optimum operating economy, the pump should be selected on the basis of the following criteria:

- The max. required duty point should be as close as possible to the QH curve of the pump.
- The required duty point should be positioned so that P2 is close to the max. point of the 100 % curve.

Between the min. and max. performance curve E-pumps have an infinite number of performance curves each representing a specific speed. Therefore it may not be possible to select a duty point close to the 100 % curve.

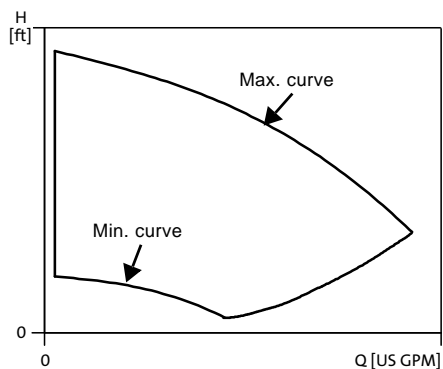

Fig. 23 Min. and max. performance curves

In situations where it is not possible to select a duty point close to the 100 % curve, the affinity equations to the right can be used. The head (H), the flow (Q) and the input power (P) are all the appropriate variables for the motor speed (n).

Note:

The approximate formulas apply on condition that the system characteristic remains unchanged for n_n and n_x , and that it is based on the formula $H = k \times Q^2$, where k is a constant.

The power equation implies that the pump efficiency is unchanged at the two speeds. In practice this is **not** correct.

Finally, it is worth noting that the efficiencies of the frequency converter and the motor **must** be taken into account if a precise calculation of the power saving resulting from a reduction of the pump speed is wanted.

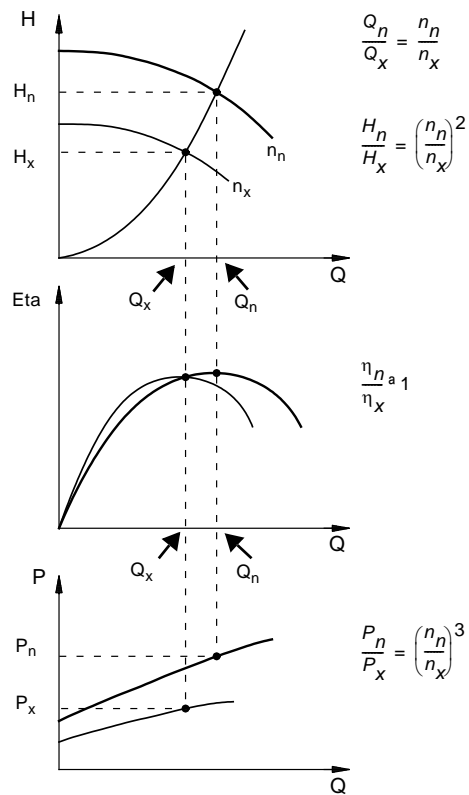

Fig. 24 Affinity equations

Legend

H_n	Rated head in feet
H_x	Current head in feet
Q_n	Rated flow in US gpm
Q_x	Current flow in US gpm
n_n	Rated motor speed in min^{-1} ($n_n = 3500 \text{ min}^{-1}$)
n_x	Current motor speed in min^{-1}
η_n	Rated efficiency in %
η_x	Current efficiency in %

WinCAPS and WebCAPS

Grundfos offers the two selection programs WinCAPS and WebCAPS.

The two programs make it possible to calculate an E-pump's specific duty point and energy consumption.

By entering the sizing data of the pump, WinCAPS and WebCAPS can calculate the exact duty point and energy consumption. For further information see page 111 and page 112.

3. Pump materials

The material variant CR-H, CRE-H should be selected based on the liquid to be pumped. The product range covers one basic type.

- The CR-H, CRE-H pump types are suitable for clean, non-aggressive liquids such as potable water, oils, some chemicals, etc.

4. Piping dimensions

CR-H, CRE-H pumps can be selected to comply with ANSI/ASME B73.1 piping and most baseplate dimensions based on the ANSI/ASME B73.1.

CR-H, CRE-H pumps can also be selected with Grundfos end-suction piping dimensions (GA is the only connector type available for CR, CRE 1s, 1, 3, 5 H pumps. See chart on page 7 for G22, G33, and G44 availability). When selecting your pump, please note:

	Pipe connection (inlet x discharge x impeller size reference)
GA	ANSI 1.5" x 1" x 6", 1.5" x 1" x 8"
G05	ANSI 2" x 1" x 10"
GB	ANSI 3" x 1.5" x 6", 3" x 1.5" x 8"
GC	ANSI 3" x 2" x 6"
G10	ANSI 3" x 2" x 6"
G50	ANSI 3" x 1.5" x 8", 3" x 1.5" x 10"
G60	ANSI 3" x 2" x 8", 3" x 2" x 10"
G20	ANSI 3" x 1.5" x 13"
G30	ANSI 3" x 2" x 13"
G70	ANSI 4" x 3" x 8", 4" x 3" x 10"
G40	ANSI 4" x 3" x 10", 4" x 3" x 13"
G22	ANSI 2" x 2"
G33	ANSI 3" x 3"
G44	ANSI 4" x 4"

5. Shaft seal

As standard, the CR-H, CRE-H range is fitted with a Grundfos shaft seal (cartridge type) suitable for the most common applications. See fig. 27.

The following three key parameters **must** be taken into account, when selecting the shaft seal:

- type of pumped liquid
- liquid temperature
- maximum pressure.

Grundfos offers a wide range of shaft seal variants to meet specific demands. See *List of pumped liquids* on page 100.

6. Inlet pressure and operating pressure

Do **not** exceed the limit values stated on pages 15 and 17 as regards these pressures:

- maximum inlet pressure
- maximum operating pressure.

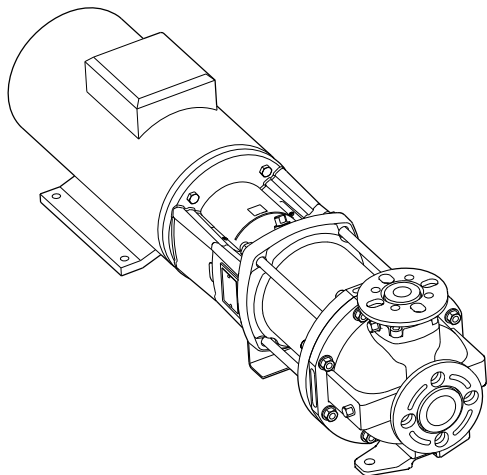

TM04 4539 1609

Fig. 25 CR-H pump

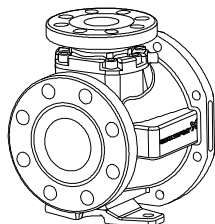

TM04 4039 0609

Fig. 26 Pump connections

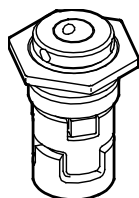

TM02 0538 4800

Fig. 27 Shaft seal (cartridge type)

Minimum inlet pressure - NPSHA

Calculation of the inlet pressure "H" is recommended in these situations:

- The liquid temperature is high.
- The flow is significantly higher than the rated flow.
- Water is drawn from depths.
- Water is drawn through long pipes.
- Inlet conditions are poor.

To avoid cavitation, make sure that there is a minimum pressure on the suction side of the pump. The maximum suction lift "H" in feet can be calculated as follows:

$$H = p_b - \text{NPSHR} - H_f - H_v - H_s$$

P_b = Barometric pressure in feet absolute.
(Barometric pressure can be set to 33.9 feet at sea level. In closed systems, p_b indicates system pressure in feet.)

NPSHR = Net Positive Suction Head Required in feet.
(To be read from the NPSHR curve at the highest flow the pump will be delivering.)

H_f = Friction loss in suction pipe in feet.
(At the highest flow the pump will be delivering.)

H_v = Vapor pressure in feet.
(To be read from the vapor pressure scale. " H_v " depends on the liquid temperature " T_m ".)

H_s = Safety margin = minimum 2.0 feet.

If the "H" calculated is positive, the pump can operate at a suction lift of maximum "H" feet.

If the "H" calculated is negative, an inlet pressure of minimum "H" feet is required.

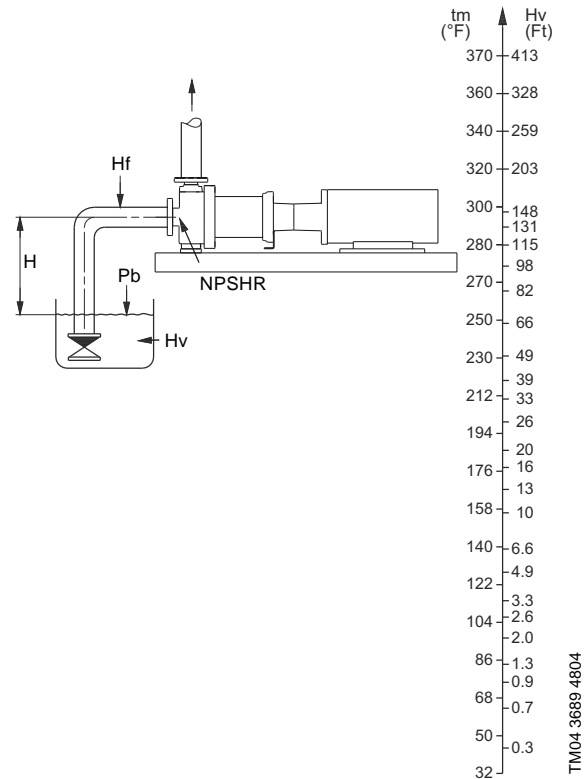

Fig. 28 Minimum inlet pressure - NPSHR

Note: In order to avoid cavitation **never** select a pump whose duty point lies too far to the right on the NPSHR curve.

Always check the NPSHR value of the pump at the highest possible flow. The NPSHR curves can be found in the curve charts on pages 26 to 54.

Maximum inlet pressure

The table on page 17 states the maximum permissible inlet pressure. However, the actual inlet pressure + maximum pump pressure (at no flow) must always be lower than the values stated in the table on page 15.

The pumps are pressure-tested at a pressure of 1.5 times the values stated on page 15.

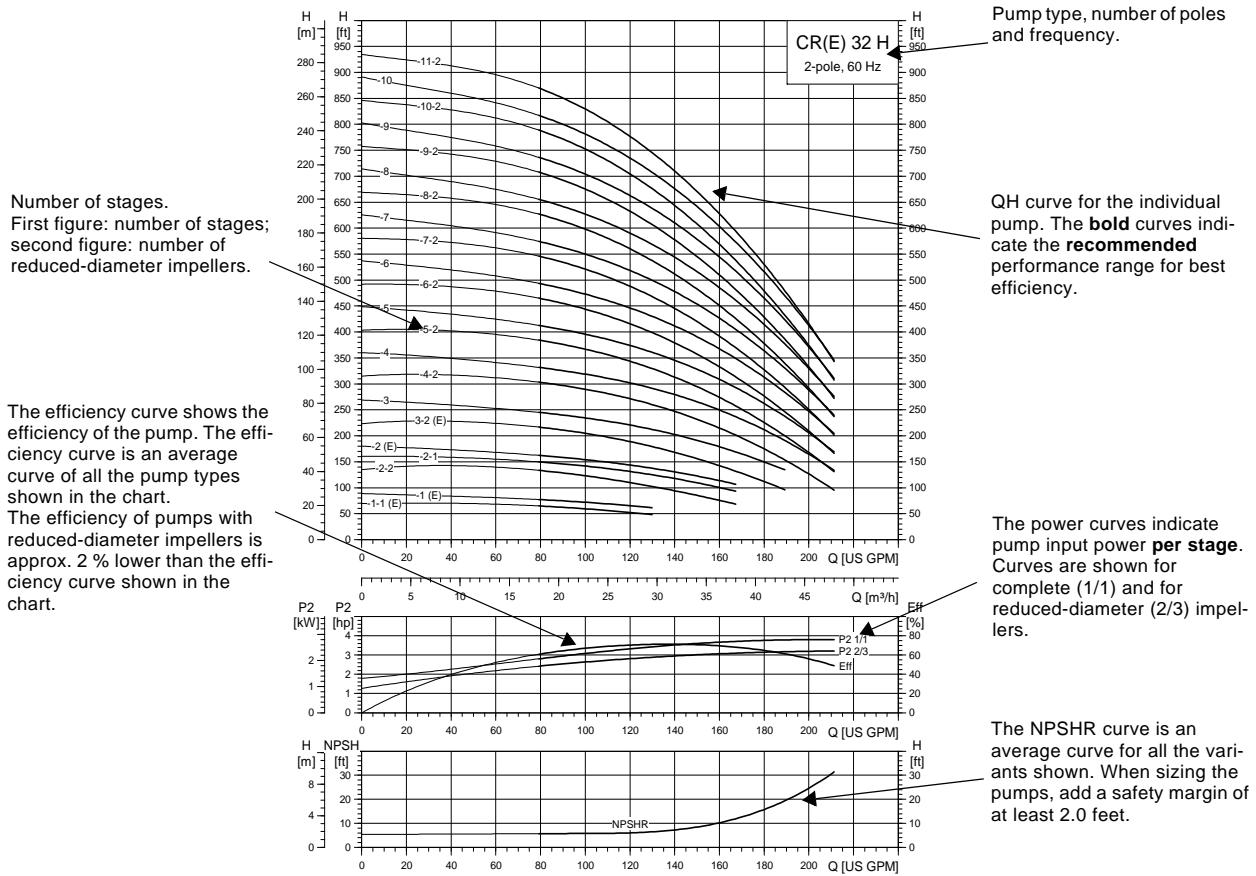

Fig. 29 How to read the curve charts

Guidelines to the curve charts

The guidelines below apply to the curves shown on the following pages:

- The motors used for the measurements are standard motors (TEFC or MLE).
- Measurements have been made with airless water at a temperature of 68 °F (20 °C).
- The curves apply to a kinematic viscosity of $\nu = 1 \text{ mm}^2/\text{s}$ (1 cSt).
- Due to the risk of overheating, the pumps should not be used at a flow below the minimum flow rate.
- The QH curves apply to actual speed with the motor types mentioned at 60 Hz.

The curve below shows the minimum flow rate as a percentage of the rated flow rate in relation to the liquid temperature. The dotted line shows a CR-H pump fitted with an air-cooled top assembly.

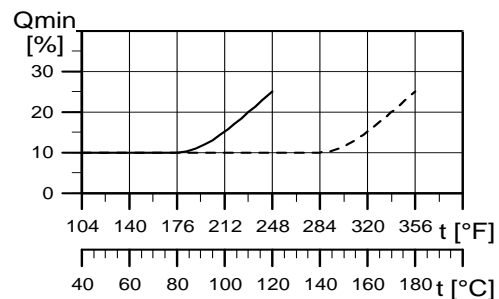
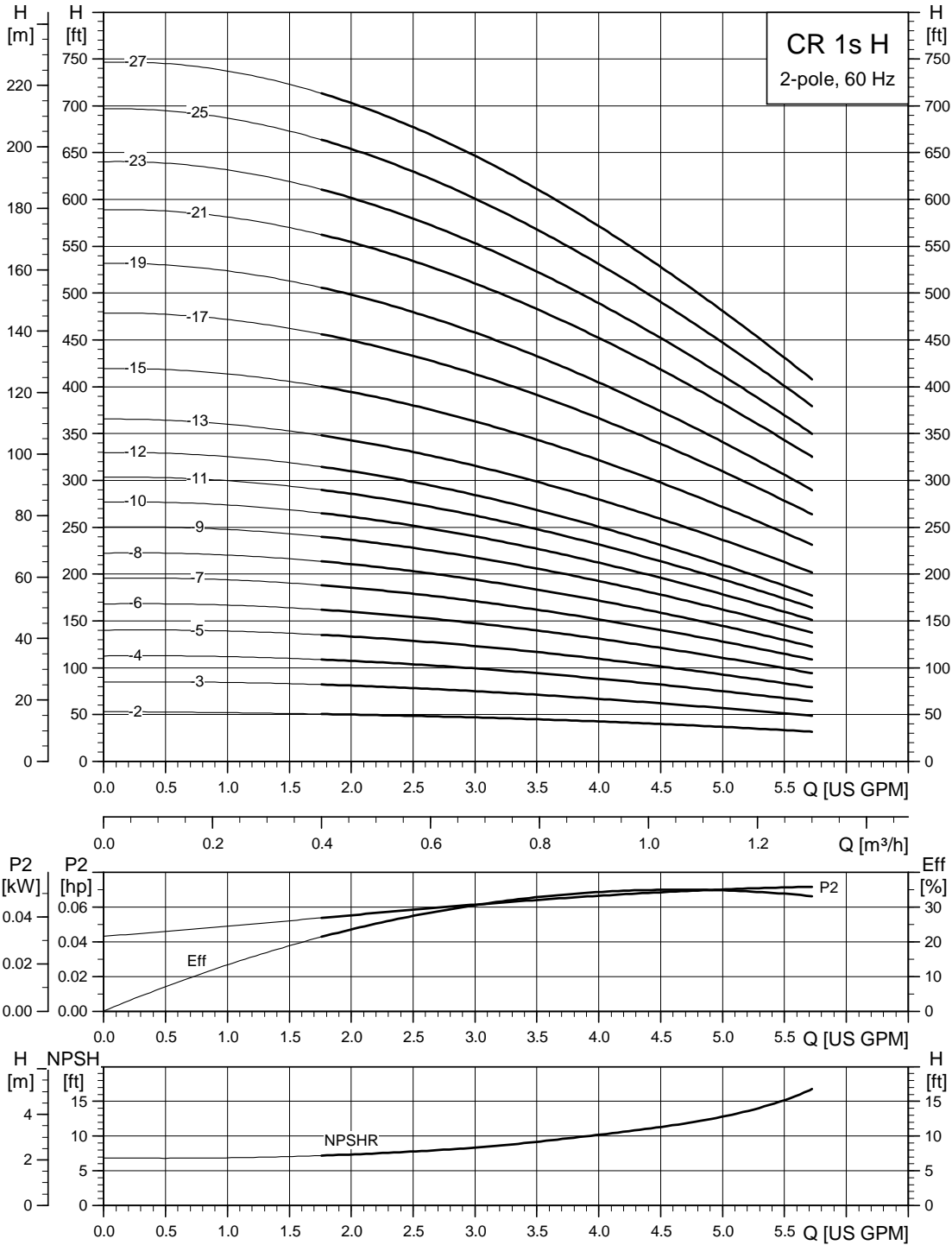

Fig. 30 Minimum flow rate

TM04 4551 1609

TM02 7538 3703

CR 1s H



TM04 4545 1609

Dimensional sketches GA (1.5" x 1" x 6", 1.5" x 1" x 8")

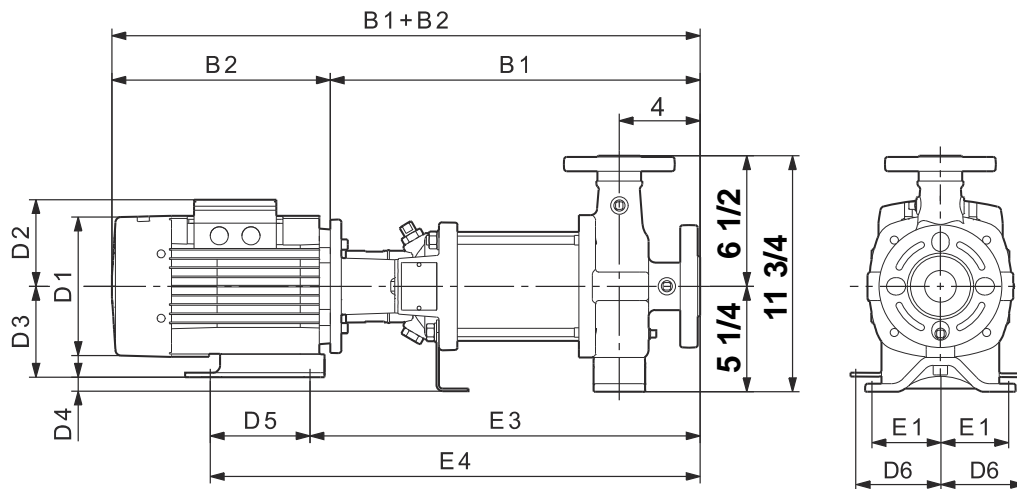

TM04 4642 0510

Dimensions and weights GA (1.5" x 1" x 6", 1.5" x 1" x 8")

Pump type	Power [hp]	Ph	Dimensions [inches]											Ship. weight [lbs]
			TEFC											
			B1	B1+B2	E1	E3	E4	D1	D2	D3	D4	D5	D6	
CR 1s-2 H	0.33	1	13.13	22.38	3.00	15.75	18.75	6.25	5.25	3.50	1.75	3.00	2.44	—
		3	13.13	20.75	3.00	15.75	18.75	5.63	4.63	3.50	1.75	3.00	2.44	—
CR 1s-3 H	0.33	1	13.13	22.38	3.00	15.75	18.75	6.25	5.25	3.50	1.75	3.00	2.44	—
		3	13.13	20.75	3.00	15.75	18.75	5.63	4.63	3.50	1.75	3.00	2.44	—
CR 1s-4 H	0.33	1	13.88	23.13	3.00	16.50	19.50	6.25	5.25	3.50	1.75	3.00	2.44	—
		3	13.88	21.50	3.00	16.50	19.50	5.63	4.63	3.50	1.75	3.00	2.44	—
CR 1s-5 H	0.33	1	14.50	23.88	3.00	17.13	20.13	6.25	5.25	3.50	1.75	3.00	2.44	—
		3	14.50	22.13	3.00	17.13	20.13	5.63	4.63	3.50	1.75	3.00	2.44	—
CR 1s-6 H	0.5	1	15.25	24.50	3.00	17.88	20.88	6.25	5.25	3.50	1.75	3.00	2.44	—
		3	15.25	22.88	3.00	17.88	20.88	5.63	4.63	3.50	1.75	3.00	2.44	—
CR 1s-7 H	0.5	1	16.00	25.25	3.00	18.63	21.63	6.25	5.25	3.50	1.75	3.00	2.44	—
		3	16.00	23.63	3.00	18.63	21.63	5.63	4.63	3.50	1.75	3.00	2.44	—
CR 1s-8 H	0.5	1	16.63	26.00	3.00	19.25	22.25	6.25	5.25	3.50	1.75	3.00	2.44	—
		3	16.63	24.25	3.00	19.25	22.25	5.63	4.63	3.50	1.75	3.00	2.44	—
CR 1s-9 H	0.75	1	17.38	27.25	3.00	20.00	23.00	6.25	5.25	3.50	1.75	3.00	2.44	—
		3	17.38	25.00	3.00	20.00	23.00	5.63	4.63	3.50	1.75	3.00	2.44	—
CR 1s-10 H	0.75	1	18.13	28.00	3.00	20.75	23.75	6.25	5.25	3.50	1.75	3.00	2.44	—
		3	18.13	25.75	3.00	20.75	23.75	5.63	4.63	3.50	1.75	3.00	2.44	—
CR 1s-11 H	0.75	1	18.75	28.75	3.00	21.38	24.38	6.25	5.25	3.50	1.75	3.00	2.44	—
		3	18.75	26.38	3.00	21.38	24.38	5.63	4.63	3.50	1.75	3.00	2.44	—
CR 1s-12 H	0.75	1	19.50	29.38	3.00	22.13	25.13	6.25	5.25	3.50	1.75	3.00	2.44	—
		3	19.50	27.13	3.00	22.13	25.13	5.63	4.63	3.50	1.75	3.00	2.44	—
CR 1s-13 H	1	1	20.25	31.38	3.00	22.88	25.88	6.25	5.25	3.50	1.75	3.00	2.44	—
		3	20.25	27.88	3.00	22.88	25.88	5.63	4.63	3.50	1.75	3.00	2.44	—
CR 1s-15 H	1	1	21.63	32.88	3.00	24.25	27.25	6.25	5.25	3.50	1.75	3.00	2.44	—
		3	21.63	29.25	3.00	24.25	27.25	5.63	4.63	3.50	1.75	3.00	2.44	—
CR 1s-17 H	1.5	1	23.00	34.75	3.00	25.63	28.63	7.25	5.75	3.50	1.75	3.00	2.44	—
		3	23.00	31.88	3.00	25.63	28.63	5.63	4.63	3.50	1.75	3.00	2.44	—
CR 1s-19 H	1.5	1	24.50	36.13	3.00	27.13	30.13	7.25	5.75	3.50	1.75	3.00	2.44	—
		3	24.50	33.25	3.00	27.13	30.13	5.63	4.63	3.50	1.75	3.00	2.44	—
CR 1s-21 H	1.5	1	25.88	37.63	3.00	28.50	31.50	7.25	5.75	3.50	1.75	3.00	2.44	—
		3	25.88	34.75	3.00	28.50	31.50	5.63	4.63	3.50	1.75	3.00	2.44	—
CR 1s-23 H	1.5	1	27.25	39.00	3.00	29.88	32.88	7.25	5.75	3.50	1.75	3.00	2.44	—
		3	27.25	36.13	3.00	29.88	32.88	5.63	4.63	3.50	1.75	3.00	2.44	—
CR 1s-25 H	2	1	28.75	41.25	3.00	31.38	34.38	7.25	5.75	3.50	1.75	3.00	2.44	—
		3	28.75	40.13	3.00	31.38	34.38	7.13	4.38	3.50	1.75	3.00	2.44	—
CR 1s-27 H	2	1	30.13	42.75	3.00	32.75	35.75	7.25	5.75	3.50	1.75	3.00	2.44	—
		3	30.13	41.63	3.00	32.75	35.75	7.13	4.38	3.50	1.75	3.00	2.44	—

Note: Terminal box is on top of motor on 3-phase up to 10 hp. All other motors have terminal box on the side. Reference D2 dimension.

CR, CRE 1 H

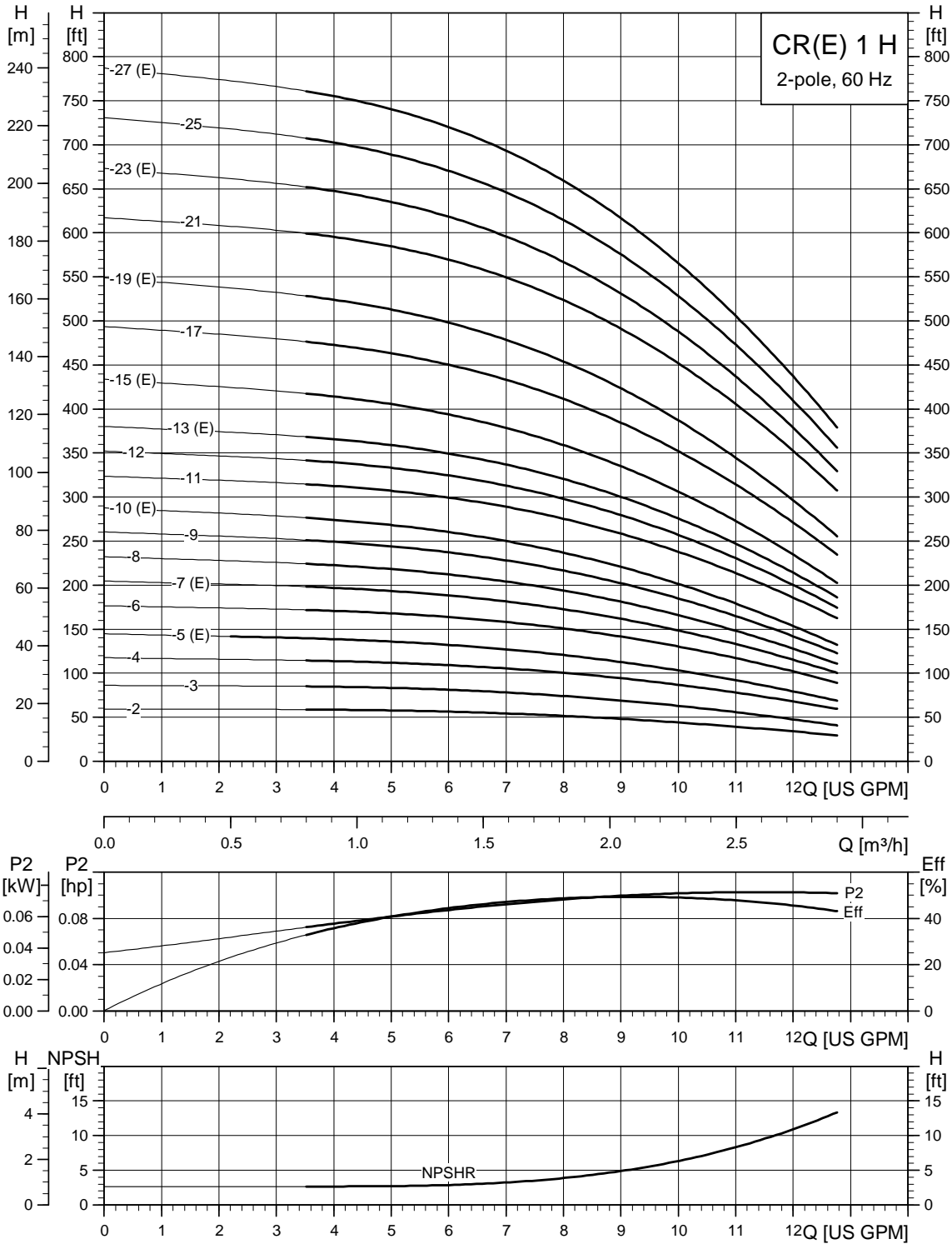

TM04 4546 1609

Dimensional sketches GA (1.5" x 1" x 6", 1.5" x 1" x 8")

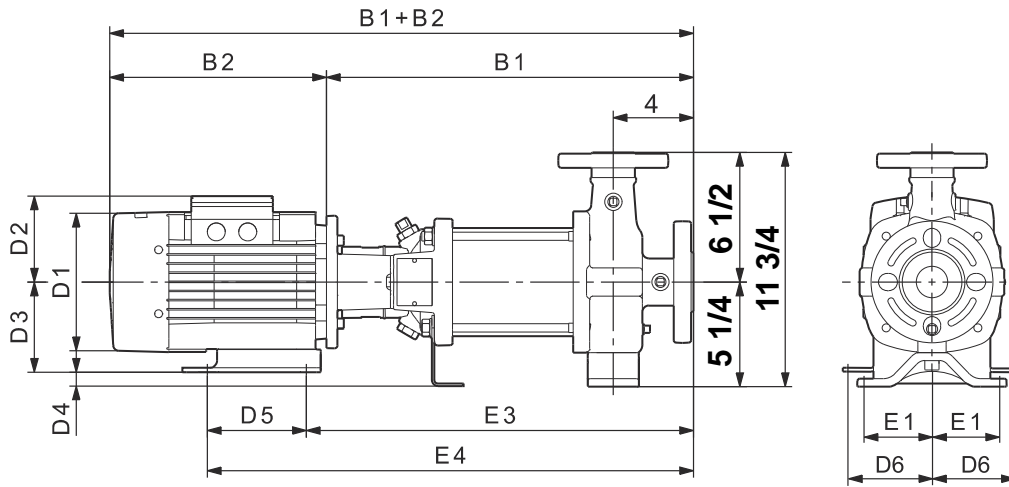

TM04 4642 0310

Dimensions and weights GA (1.5" x 1" x 6", 1.5" x 1" x 8")

Pump type	Power [hp]	Ph	Dimensions [inches]											Ship. weight [lbs]	Dimensions [inches]			Ship. weight [lbs]
			TEFC												MLE			
			B1	B1+B2	E1	E3	E4	D1	D2	D3	D4	D5	D6		D1	D2	B1+B2	
CR 1-2 H	0.33	1	13.13	22.38	3.00	15.75	18.75	6.25	5.25	3.50	1.75	3.00	2.44	—	—	—	—	—
		3	13.13	20.75	3.00	15.75	18.75	5.63	4.63	3.50	1.75	3.00	2.44	—	—	—	—	—
CR 1-3 H	0.33	1	13.13	22.38	3.00	15.75	18.75	6.25	5.25	3.50	1.75	3.00	2.44	—	—	—	—	—
		3	13.13	20.75	3.00	15.75	18.75	5.63	4.63	3.50	1.75	3.00	2.44	—	—	—	—	—
CR 1-4 H	0.5	1	13.88	23.13	3.00	16.50	19.50	6.25	5.25	3.50	1.75	3.00	2.44	—	—	—	—	—
		3	13.88	21.50	3.00	16.50	19.50	5.63	4.63	3.50	1.75	3.00	2.44	—	—	—	—	—
CR(E) 1-5 H	0.5	1	14.50	23.88	3.00	17.13	20.13	6.25	5.25	3.50	1.75	3.00	2.44	—	5.63	5.63	22.13	—
		3	14.50	22.13	3.00	17.13	20.13	5.63	4.63	3.50	1.75	3.00	2.44	—	—	—	—	—
CR 1-6 H	0.75	1	15.25	25.13	3.00	17.88	20.88	6.25	5.25	3.50	1.75	3.00	2.44	—	—	—	—	—
		3	15.25	22.88	3.00	17.88	20.88	5.63	4.63	3.50	1.75	3.00	2.44	—	—	—	—	—
CR(E) 1-7 H	0.75	1	16.00	25.88	3.00	18.63	21.63	6.25	5.25	3.50	1.75	3.00	2.44	—	5.63	5.63	23.50	—
		3	16.00	23.63	3.00	18.63	21.63	5.63	4.63	3.50	1.75	3.00	2.44	—	—	—	—	—
CR 1-8 H	1	1	16.63	27.88	3.00	19.25	22.25	6.25	5.25	3.50	1.75	3.00	2.44	—	—	—	—	—
		3	16.63	24.25	3.00	19.25	22.25	5.63	4.63	3.50	1.75	3.00	2.44	—	—	—	—	—
CR 1-9 H	1	1	17.38	28.63	3.00	20.00	23.00	6.25	5.25	3.50	1.75	3.00	2.44	—	—	—	—	—
		3	17.38	25.00	3.00	20.00	23.00	5.63	4.63	3.50	1.75	3.00	2.44	—	—	—	—	—
CR(E) 1-10 H	1	1	18.13	29.25	3.00	20.75	23.75	6.25	5.25	3.50	1.75	3.00	2.44	—	5.63	5.63	27.25	—
		3	18.13	25.75	3.00	20.75	23.75	5.63	4.63	3.50	1.75	3.00	2.44	—	7.13	6.63	31.00	—
CR 1-11 H	1.5	1	18.75	30.50	3.00	21.38	24.38	7.25	5.75	3.50	1.75	3.00	2.44	—	—	—	—	—
		3	18.75	27.63	3.00	21.38	24.38	5.63	4.63	3.50	1.75	3.00	2.44	—	—	—	—	—
CR 1-12 H	1.5	1	19.50	31.25	3.00	22.13	25.13	7.25	5.75	3.50	1.75	3.00	2.44	—	—	—	—	—
		3	19.50	28.38	3.00	22.13	25.13	5.63	4.63	3.50	1.75	3.00	2.44	—	—	—	—	—
CR(E) 1-13 H	1.5	1	20.25	31.88	3.00	22.88	25.88	7.25	5.75	3.50	1.75	3.00	2.44	—	5.63	5.63	29.38	—
		3	20.25	29.00	3.00	22.88	25.88	5.63	4.63	3.50	1.75	3.00	2.44	—	7.13	6.63	33.13	—
CR(E) 1-15 H	2	1	21.63	34.25	3.00	24.25	27.25	7.25	5.75	3.50	1.75	3.00	2.44	—	—	—	—	—
		3	21.63	33.13	3.00	24.25	27.25	7.13	4.38	3.50	1.75	3.00	2.44	—	7.13	6.63	34.63	—
CR 1-17 H	2	1	23.00	35.63	3.00	25.63	28.63	7.25	5.75	3.50	1.75	3.00	2.44	—	—	—	—	—
		3	23.00	34.50	3.00	25.63	28.63	7.13	4.38	3.50	1.75	3.00	2.44	—	—	—	—	—
CR(E) 1-19 H	2	1	24.50	37.00	3.00	27.13	30.13	7.25	5.75	3.50	1.75	3.00	2.44	—	—	—	—	—
		3	24.50	35.88	3.00	27.13	30.13	7.13	4.38	3.50	1.75	3.00	2.44	—	7.13	6.63	37.38	—
CR 1-21 H	3	1	27.00	41.38	3.00	29.50	34.00	8.63	6.88	4.50	0.75	4.50	3.75	—	—	—	—	—
		3	27.00	40.25	3.00	29.50	34.00	7.13	4.38	4.50	0.75	4.50	3.75	—	—	—	—	—
CR(E) 1-23 H	3	1	28.38	42.75	3.00	30.88	35.38	8.63	6.88	4.50	0.75	4.50	3.75	—	—	—	—	—
		3	28.38	41.63	3.00	30.88	35.38	7.13	4.38	4.50	0.75	4.50	3.75	—	7.13	6.63	41.75	—
CR 1-25 H	3	1	29.88	44.25	3.00	32.38	36.88	8.63	6.88	4.50	0.75	4.50	3.75	—	—	—	—	—
		3	29.88	43.13	3.00	32.38	36.88	7.13	4.38	4.50	0.75	4.50	3.75	—	—	—	—	—
CR(E) 1-27 H	3	1	31.25	45.63	3.00	33.75	38.25	8.63	6.88	4.50	0.75	4.50	3.75	—	—	—	—	—
		3	31.25	44.50	3.00	33.75	38.25	7.13	4.38	4.50	0.75	4.50	3.75	—	7.13	6.63	44.50	—

Note: Terminal box is on top of motor on 3-phase up to 10 hp. All other motors have terminal box on the side. Reference D2 dimension.

CR, CRE 3 H

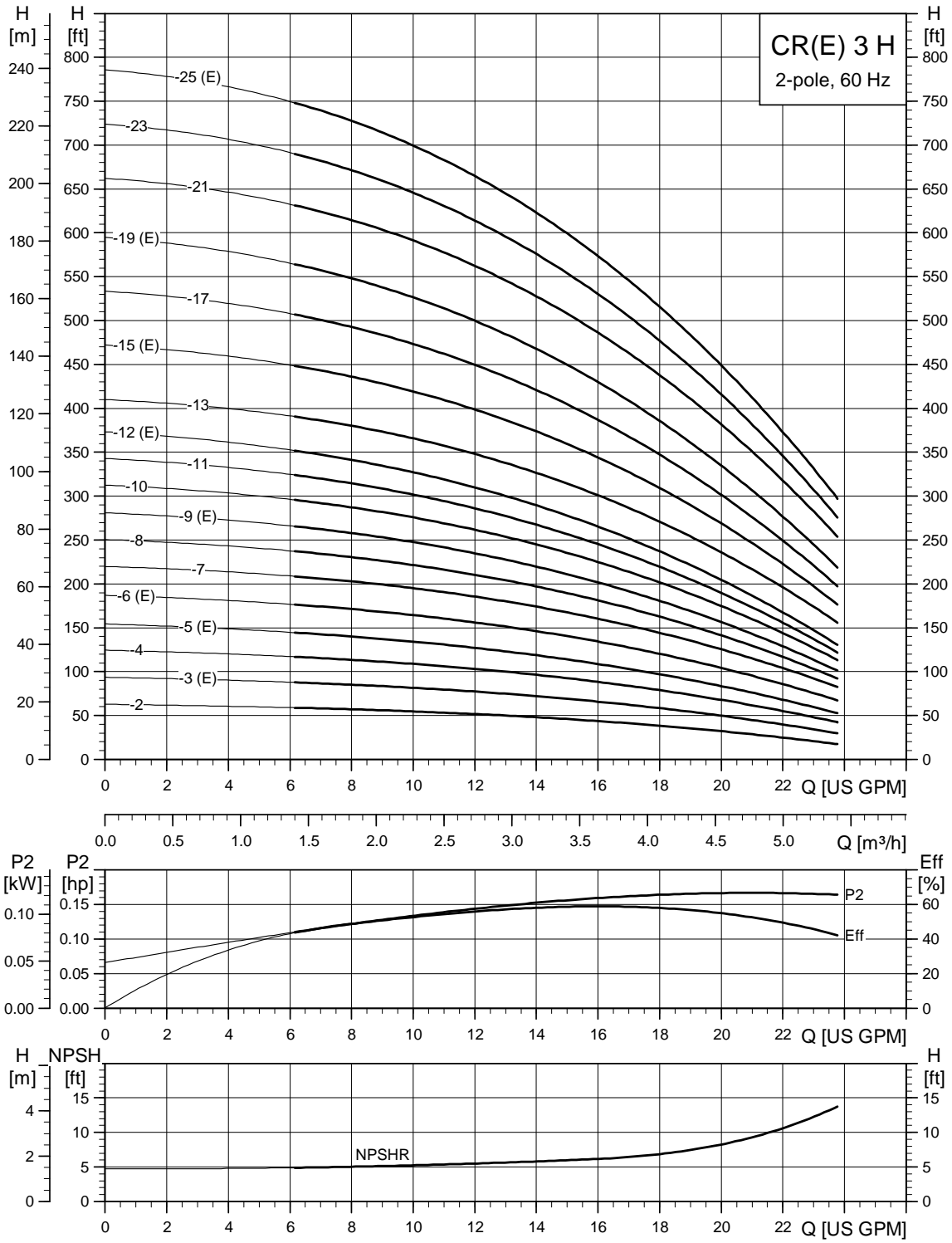

TM044547 1609

Dimensional sketches GA (1.5" x 1" x 6", 1.5" x 1" x 8")

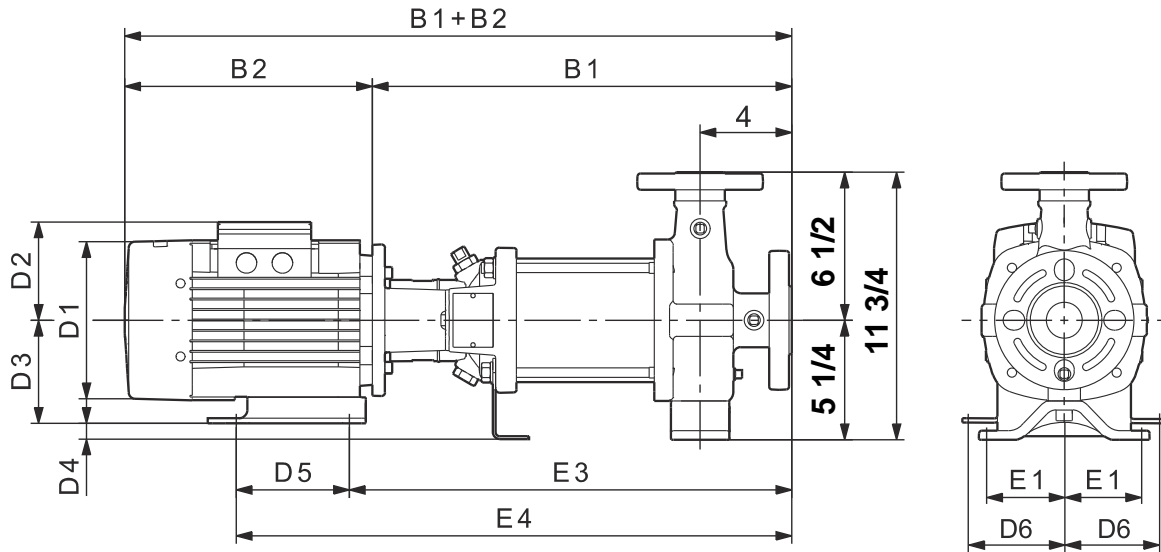

Dimensions and weights GA (1.5" x 1" x 6", 1.5" x 1" x 8")

Pump type	Power [hp]	Ph	Dimensions [inches]											Ship. weight [lbs]	Dimensions [inches]			Ship. weight [lbs]
			TEFC												MLE			
			B1	B1+B	E1	E3	E4	D1	D2	D3	D4	D5	D6		D1	D2	B1+B	
CR 3-2 H	0.33	1	13.13	22.38	3.00	15.75	18.75	6.25	5.25	3.50	1.75	3.00	2.44	—	—	—	—	—
		3	13.13	20.75	3.00	15.75	18.75	5.63	4.63	3.50	1.75	3.00	2.44	—	—	—	—	—
CR(E) 3-3 H	0.5	1	13.13	22.38	3.00	15.75	18.75	6.25	5.25	3.50	1.75	3.00	2.44	—	5.63	5.63	20.63	—
		3	13.13	20.75	3.00	15.75	18.75	5.63	4.63	3.50	1.75	3.00	2.44	—	—	—	—	—
CR 3-4 H	0.75	1	13.88	23.75	3.00	16.50	19.50	6.25	5.25	3.50	1.75	3.00	2.44	—	—	—	—	—
		3	13.88	21.50	3.00	16.50	19.50	5.63	4.63	3.50	1.75	3.00	2.44	—	—	—	—	—
CR(E) 3-5 H	0.75	1	14.50	24.50	3.00	17.13	20.13	6.25	5.25	3.50	1.75	3.00	2.44	—	5.63	5.63	22.13	—
		3	14.50	22.13	3.00	17.13	20.13	5.63	4.63	3.50	1.75	3.00	2.44	—	—	—	—	—
CR(E) 3-6 H	1	1	15.25	26.50	3.00	17.88	20.88	6.25	5.25	3.50	1.75	3.00	2.44	—	5.63	5.63	24.38	—
		3	15.25	22.88	3.00	17.88	20.88	5.63	4.63	3.50	1.75	3.00	2.44	—	7.13	6.63	28.25	—
CR 3-7 H	1.5	1	16.00	27.63	3.00	18.63	21.63	7.25	5.75	3.50	1.75	3.00	2.44	—	—	—	—	—
		3	16.00	24.75	3.00	18.63	21.63	5.63	4.63	3.50	1.75	3.00	2.44	—	—	—	—	—
CR 3-8 H	1.5	1	16.63	28.38	3.00	19.25	22.25	7.25	5.75	3.50	1.75	3.00	2.44	—	—	—	—	—
		3	16.63	25.50	3.00	19.25	22.25	5.63	4.63	3.50	1.75	3.00	2.44	—	—	—	—	—
CR(E) 3-9 H	1.5	1	17.38	29.13	3.00	20.00	23.00	7.25	5.75	3.50	1.75	3.00	2.44	—	5.63	5.63	26.50	—
		3	17.38	26.25	3.00	20.00	23.00	5.63	4.63	3.50	1.75	3.00	2.44	—	7.13	6.63	30.38	—
CR 3-10 H	2	1	18.13	30.63	3.00	20.75	23.75	7.25	5.75	3.50	1.75	3.00	2.44	—	—	—	—	—
		3	18.13	29.50	3.00	20.75	23.75	7.13	4.38	3.50	1.75	3.00	2.44	—	—	—	—	—
CR 3-11 H	2	1	18.75	31.38	3.00	21.38	24.38	7.25	5.75	3.50	1.75	3.00	2.44	—	—	—	—	—
		3	18.75	30.25	3.00	21.38	24.38	7.13	4.38	3.50	1.75	3.00	2.44	—	—	—	—	—
CR(E) 3-12 H	2	1	19.50	32.13	3.00	22.13	25.13	7.25	5.75	3.50	1.75	3.00	2.44	—	—	—	—	—
		3	19.50	31.00	3.00	22.13	25.13	7.13	4.38	3.50	1.75	3.00	2.44	—	7.13	6.63	32.50	—
CR 3-13 H	3	1	21.25	35.75	3.00	23.75	28.25	8.63	6.88	4.50	0.75	4.50	3.75	—	—	—	—	—
		3	21.25	34.50	3.00	23.75	28.25	7.13	4.38	4.50	0.75	4.50	3.75	—	—	—	—	—
CR(E) 3-15 H	3	1	22.75	37.13	3.00	25.25	29.75	8.63	6.88	4.50	0.75	4.50	3.75	—	—	—	—	—
		3	22.75	36.00	3.00	25.25	29.75	7.13	4.38	4.50	0.75	4.50	3.75	—	7.13	6.63	36.00	—
CR 3-17 H	3	1	24.13	38.50	3.00	26.63	31.13	8.63	6.88	4.50	0.75	4.50	3.75	—	—	—	—	—
		3	24.13	37.38	3.00	26.63	31.13	7.13	4.38	4.50	0.75	4.50	3.75	—	—	—	—	—
CR(E) 3-19 H	3	1	25.50	40.00	3.00	28.00	32.50	8.63	6.88	4.50	0.75	4.50	3.75	—	—	—	—	—
		3	25.50	38.75	3.00	28.00	32.50	7.13	4.38	4.50	0.75	4.50	3.75	—	7.13	6.63	38.88	—
CR 3-21 H	5	1	27.00	42.25	3.00	29.50	34.00	10.63	7.50	4.50	0.75	4.50	3.75	—	—	—	—	—
		3	27.00	42.50	3.00	29.50	34.00	8.75	5.38	4.50	0.75	4.50	3.75	—	—	—	—	—
CR 3-23 H	5	1	28.38	43.63	3.00	30.88	35.38	10.63	7.50	4.50	0.75	4.50	3.75	—	—	—	—	—
		3	28.38	43.88	3.00	30.88	35.38	8.75	5.38	4.50	0.75	4.50	3.75	—	—	—	—	—
CR(E) 3-25 H	5	1	29.88	45.13	3.00	32.38	36.88	10.63	7.50	4.50	0.75	4.50	3.75	—	—	—	—	—
		3	29.88	45.38	3.00	32.38	36.88	8.75	5.38	4.50	0.75	4.50	3.75	—	8.75	7.50	45.38	—

Note: Terminal box is on top of motor on 3-phase up to 10 hp. All other motors have terminal box on the side. Reference D2 dimension.

CR, CRE 5 H

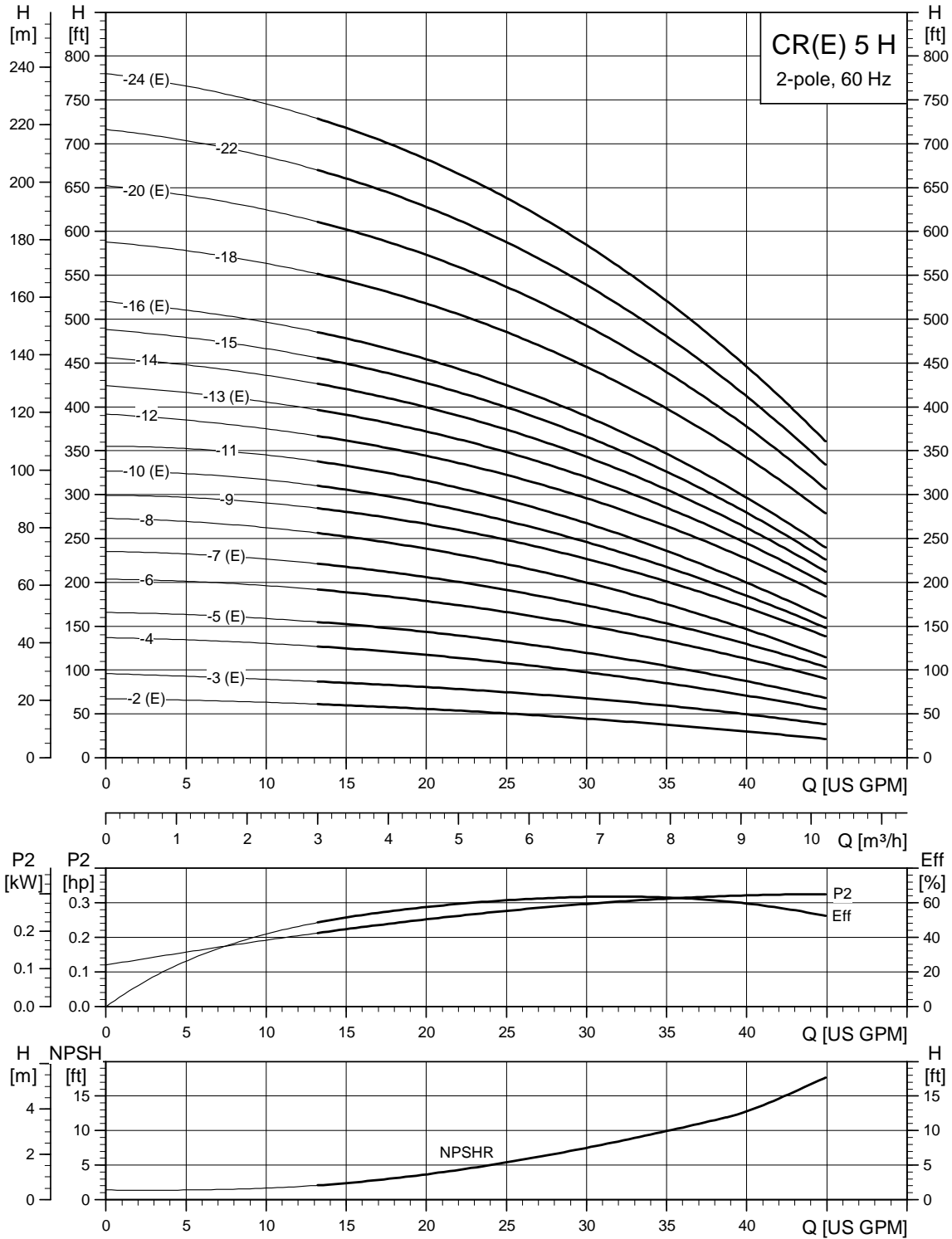

TM04.4544.1609

Dimensional sketches GA (1.5" x 1" x 6", 1.5" x 1" x 8")

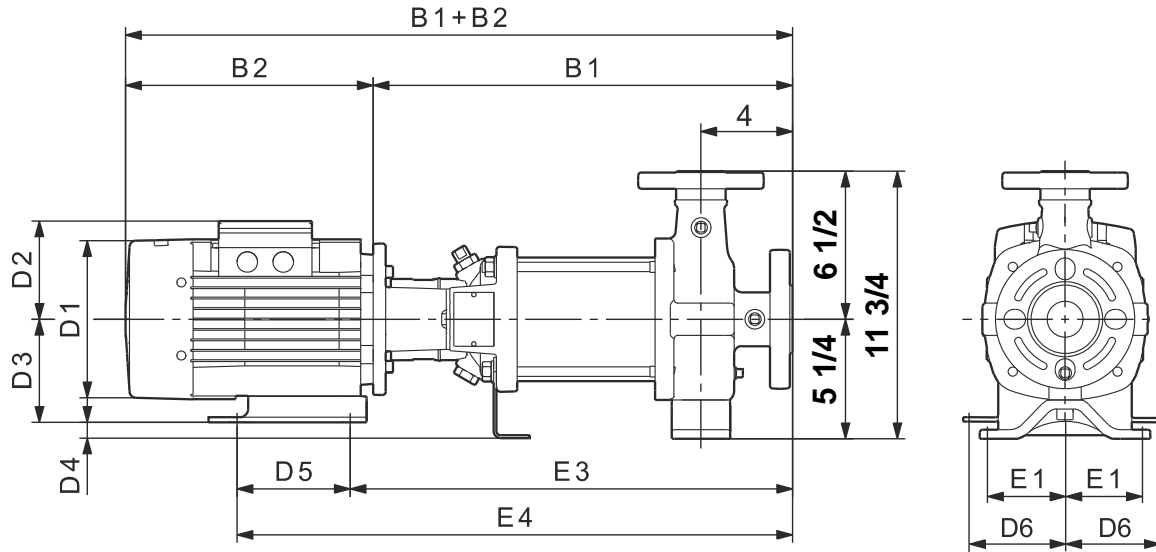

TM04 4642 0310

Dimensions and weights GA (1.5" x 1" x 6", 1.5" x 1" x 8")

Pump type	Power [hp]	Ph	Dimensions [inches]											Ship. weight [lbs]	Dimensions [inches]			Ship. weight [lbs]
			TEFC												MLE			
			B1	B1+B2	E1	E3	E4	D1	D2	D3	D4	D5	D6		D1	D2	B1+B2	
CR(E) 5-2 H	0.75	1	13.13	23	3	15.75	18.75	6.25	5.25	3.5	1.75	3	2.44	—	5.63	5.63	20.63	—
		3	13.13	20.75	3	15.75	18.75	5.63	4.63	3.5	1.75	3	2.44	—	—	—	—	—
CR(E) 5-3 H	1	1	14.25	25.38	3	16.88	19.88	6.25	5.25	3.5	1.75	3	2.44	—	5.63	5.63	23.25	—
		3	14.25	21.88	3	16.88	19.88	5.63	4.63	3.5	1.75	3	2.44	—	7.13	6.63	27.13	—
CR 5-4 H	1.5	1	15.25	27	3	17.88	20.88	7.25	5.75	3.5	1.75	3	2.44	—	—	—	—	—
		3	15.25	24.13	3	17.88	20.88	5.63	4.63	3.5	1.75	3	2.44	—	—	—	—	—
CR(E) 5-5 H	1.5	1	16.38	28	3	19	22	7.25	5.75	3.5	1.75	3	2.44	—	5.63	5.63	25.38	—
		3	16.38	25.13	3	19	22	5.63	4.63	3.5	1.75	3	2.44	—	7.13	6.63	29.25	—
CR 5-6 H	2	1	17.38	30	3	20	23	7.25	5.75	3.5	1.75	3	2.44	—	—	—	—	—
		3	17.38	28.88	3	20	23	7.13	4.38	3.5	1.75	3	2.44	—	—	—	—	—
CR(E) 5-7 H	2	1	18.5	31	3	21.13	24.13	7.25	5.75	3.5	1.75	3	2.44	—	—	—	—	—
		3	18.5	29.88	3	21.13	24.13	7.13	4.38	3.5	1.75	3	2.44	—	7.13	6.63	31.38	—
CR 5-8 H	3	1	20.63	35	3	23.13	27.63	8.63	6.88	4.5	0.75	4.5	3.75	—	—	—	—	—
		3	20.63	33.88	3	23.13	27.63	7.13	4.38	4.5	0.75	4.5	3.75	—	—	—	—	—
CR 5-9 H	3	1	21.63	36.13	3	24.13	28.63	8.63	6.88	4.5	0.75	4.5	3.75	—	—	—	—	—
		3	21.63	34.88	3	24.13	28.63	7.13	4.38	4.5	0.75	4.5	3.75	—	—	—	—	—
CR(E) 5-10 H	3	1	22.75	37.13	3	25.25	29.75	8.63	6.88	4.5	0.75	4.5	3.75	—	—	—	—	—
		3	22.75	36	3	25.25	29.75	7.13	4.38	4.5	0.75	4.5	3.75	—	7.13	6.63	36.00	—
CR 5-11 H	5	1	23.75	39	3	26.25	31.75	10.63	7.5	5.25	0	5.5	3.75	—	—	—	—	—
		3	23.75	39.25	3	26.25	30.75	8.75	5.38	4.5	0.75	4.5	3.75	—	—	—	—	—
CR 5-12 H	5	1	24.88	40.13	3	27.38	32.88	10.63	7.5	5.25	0	5.5	3.75	—	—	—	—	—
		3	24.88	40.38	3	27.38	31.88	8.75	5.38	4.5	0.75	4.5	3.75	—	—	—	—	—
CR(E) 5-13 H	5	1	25.88	41.13	3	28.38	33.88	10.63	7.5	5.25	0	5.5	3.75	—	—	—	—	—
		3	25.88	41.38	3	28.38	32.88	8.75	5.38	4.5	0.75	4.5	3.75	—	8.75	7.50	41.38	—
CR 5-14 H	5	1	27	42.25	3	29.5	35	10.63	7.5	5.25	0	5.5	3.75	—	—	—	—	—
		3	27	42.5	3	29.5	34	8.75	5.38	4.5	0.75	4.5	3.75	—	—	—	—	—
CR 5-15 H	5	1	28	43.38	3	30.5	36	10.63	7.5	5.25	0	5.5	3.75	—	—	—	—	—
		3	28	43.5	3	30.5	35	8.75	5.38	4.5	0.75	4.5	3.75	—	—	—	—	—
CR(E) 5-16 H	5	1	29.13	44.38	3	31.63	37.13	10.63	7.5	5.25	0	5.5	3.75	—	—	—	—	—
		3	29.13	44.63	3	31.63	36.13	8.75	5.38	4.5	0.75	4.5	3.75	—	8.75	7.50	44.63	—
CR 5-18 H	7.5	1	31.63	46.88	3	34.88	40.38	10.25	7.63	5.25	0	5.5	4.25	—	—	—	—	—
		3	31.63	47.13	3	34.88	40.38	8.75	5.38	5.25	0	5.5	4.25	—	—	—	—	—
CR(E) 5-20 H	7.5	1	33.75	49	3	37	42.5	10.25	7.63	5.25	0	5.5	4.25	—	—	—	—	—
		3	33.75	49.25	3	37	42.5	8.75	5.38	5.25	0	5.5	4.25	—	8.75	7.50	49.25	—
CR 5-22 H	7.5	1	35.88	51.13	3	39.13	44.63	10.25	7.63	5.25	0	5.5	4.25	—	—	—	—	—
		3	35.88	51.38	3	39.13	44.63	8.75	5.38	5.25	0	5.5	4.25	—	—	—	—	—
CR(E) 5-24 H	7.5	1	38	53.25	3	41.25	46.75	10.25	7.63	5.25	0	5.5	4.25	—	—	—	—	—
		3	38	53.5	3	41.25	46.75	8.75	5.38	5.25	0	5.5	4.25	—	8.75	7.50	53.50	—

Note: Terminal box is on top of motor on 3-phase up to 10 hp. All other motors have terminal box on the side. Reference D2 dimension.

CR, CRE 10 H G22

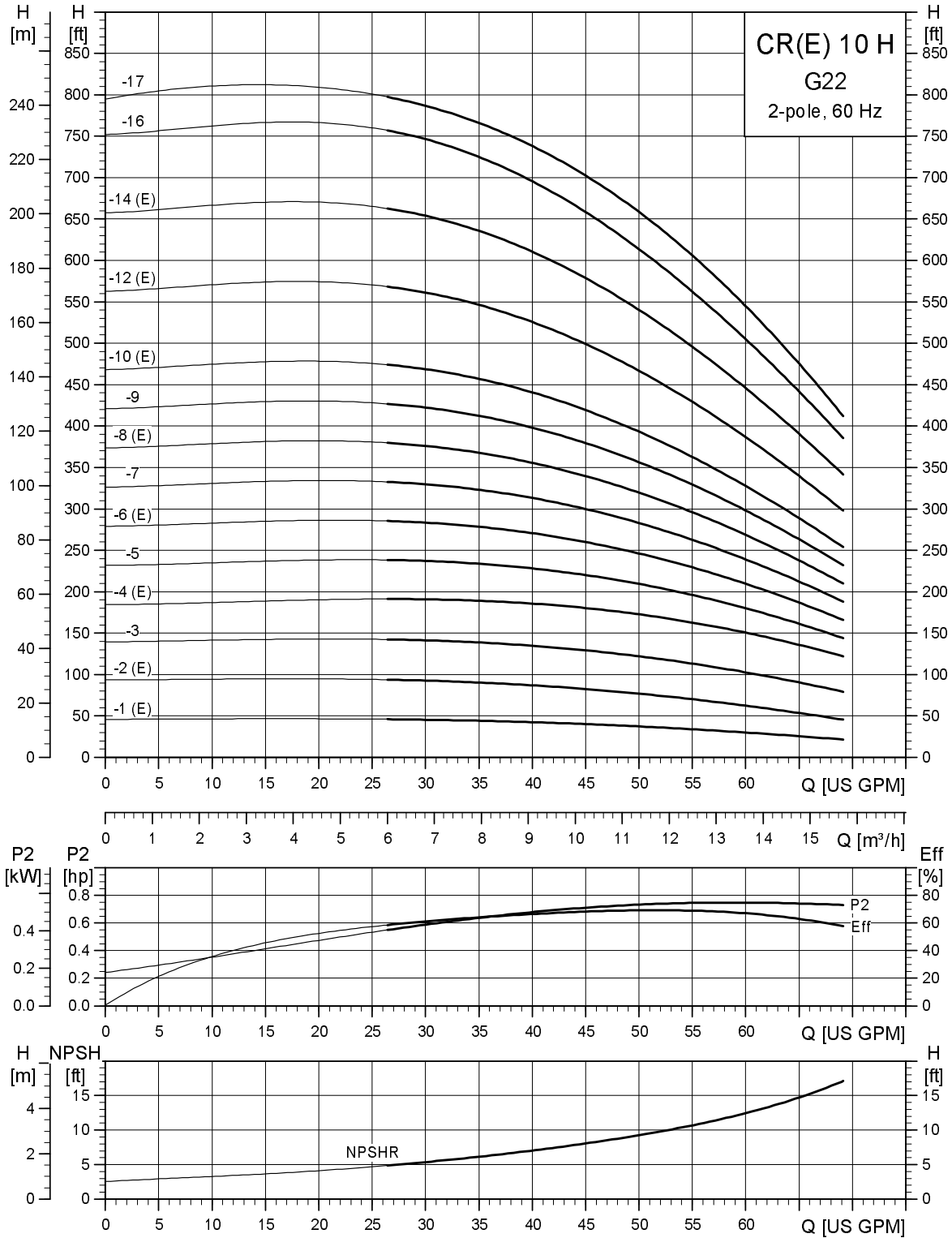

TM04 6285 0310

Dimensional sketches G22 (2" x 2")

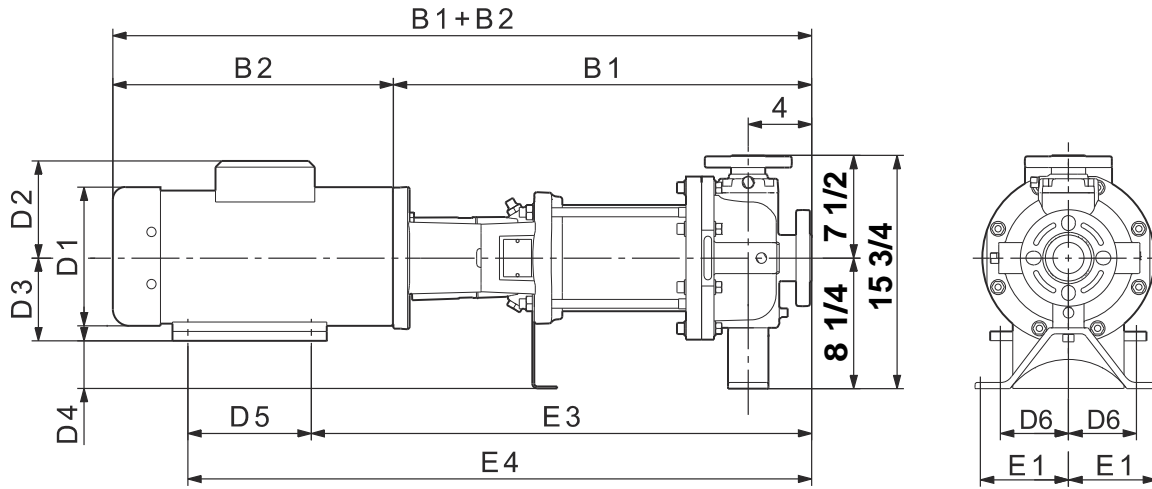

TM04 4871 0310

Dimensions and weights G22 (2" x 2")

Pump type	Power [hp]	Ph	Dimensions [inches]												Ship. weight [lbs]	Dimensions [inches]			Ship. weight [lbs]		
			TEFC										ODP			MLE					
			B1	B1+B2	E1	E3	E4	D1	D2	D3	D4	D5	D6	D1		D2	B1+B2	D1		D2	B1+B2
CR(E) 10-1 H	0.75	1	17.00	26.88	4.88	19.63	22.63	6.25	5.25	3.50	4.75	3.00	2.44	—	—	—	—	5.63	5.63	26.00	—
		3	17.00	24.63	4.88	19.63	22.63	5.63	4.63	3.50	4.75	3.00	2.44	—	—	—	—	—	—	—	—
CR(E) 10-2 H	1.5	1	17.00	28.63	4.88	19.63	22.63	7.25	5.75	3.50	4.75	3.00	2.44	—	—	—	—	5.63	5.63	26.00	—
		3	17.00	25.75	4.88	19.63	22.63	5.63	4.63	3.50	4.75	3.00	2.44	—	—	—	—	7.13	6.63	29.88	—
CR 10-3 H	3	1	20.75	35.13	4.88	23.25	27.75	8.63	6.88	4.50	3.75	4.50	3.75	—	—	—	—	—	—	—	—
		3	20.75	34.00	4.88	23.25	27.75	7.13	4.38	4.50	3.75	4.50	3.75	—	—	—	—	—	—	—	—
CR(E) 10-4 H	3	1	21.88	36.38	4.88	24.38	28.88	8.63	6.88	4.50	3.75	4.50	3.75	—	—	—	—	—	—	—	—
		3	21.88	35.13	4.88	24.38	28.88	7.13	4.38	4.50	3.75	4.50	3.75	—	—	—	—	7.13	6.63	35.25	—
CR 10-5 H	5	1	23.13	38.38	4.88	25.63	30.13	10.63	7.50	4.50	3.75	4.50	3.75	—	—	—	—	—	—	—	—
		3	23.13	38.63	4.88	25.63	30.13	8.75	5.38	4.50	3.75	4.50	3.75	—	—	—	—	—	—	—	—
CR(E) 10-6 H	5	1	24.25	39.50	4.88	26.75	31.25	10.63	7.50	4.50	3.75	4.50	3.75	—	—	—	—	—	—	—	—
		3	24.25	39.75	4.88	26.75	31.25	8.75	5.38	4.50	3.75	4.50	3.75	—	—	—	—	8.75	7.50	39.75	—
CR 10-7 H	5	1	25.50	40.75	4.88	28.00	32.50	10.63	7.50	4.50	3.75	4.50	3.75	—	—	—	—	—	—	—	—
		3	25.50	41.00	4.88	28.00	32.50	8.75	5.38	4.50	3.75	4.50	3.75	—	—	—	—	—	—	—	—
CR(E) 10-8 H	7.5	1	27.13	42.38	4.88	30.38	35.88	10.25	7.63	5.25	3.00	5.50	4.25	—	—	—	—	—	—	—	—
		3	27.13	42.63	4.88	30.38	35.88	8.75	5.38	5.25	3.00	5.50	4.25	—	—	—	—	8.75	7.50	42.63	—
CR 10-9 H	7.5	1	28.25	43.50	4.88	31.50	37.00	10.25	7.63	5.25	3.00	5.50	4.25	—	—	—	—	—	—	—	—
		3	28.25	43.75	4.88	31.50	37.00	8.75	5.38	5.25	3.00	5.50	4.25	—	—	—	—	—	—	—	—
CR(E) 10-10 H	7.5	1	29.50	44.75	4.88	32.75	38.25	10.25	7.63	5.25	3.00	5.50	4.25	—	—	—	—	—	—	—	—
		3	29.50	45.00	4.88	32.75	38.25	8.75	5.38	5.25	3.00	5.50	4.25	—	—	—	—	8.75	7.50	45.00	—
CR(E) 10-12 H	10	1	31.75	47.63	4.88	35.00	40.50	11.50	10.38	5.25	3.00	5.50	4.25	—	—	—	—	—	—	—	—
		3	31.75	47.25	4.88	35.00	40.50	8.75	5.38	5.25	3.00	5.50	4.25	—	—	—	—	8.75	7.50	47.38	—
CR(E) 10-14 H	10	1	34.13	50.00	4.88	37.38	42.88	11.50	10.38	5.25	3.00	5.50	4.25	—	—	—	—	—	—	—	—
		3	34.13	49.63	4.88	37.38	42.88	8.75	5.38	5.25	3.00	5.50	4.25	—	—	—	—	8.75	7.50	49.63	—
CR 10-16 H	15	3	37.25	55.13	4.88	41.25	49.50	10.25	8.75	6.25	2.00	8.25	5.00	10.63	6.88	53.38	—	—	—	—	—
CR 10-17 H	15	3	39.63	57.50	4.88	43.63	51.88	10.25	8.75	6.25	2.00	8.25	5.00	10.63	6.88	55.75	—	—	—	—	—

Note: Terminal box is on top of motor on 3-phase up to 10 hp. All other motors have terminal box on the side. Reference D2 dimension. Weights are based on pump with TEFC motor.

CR, CRE 10 H GA/G05

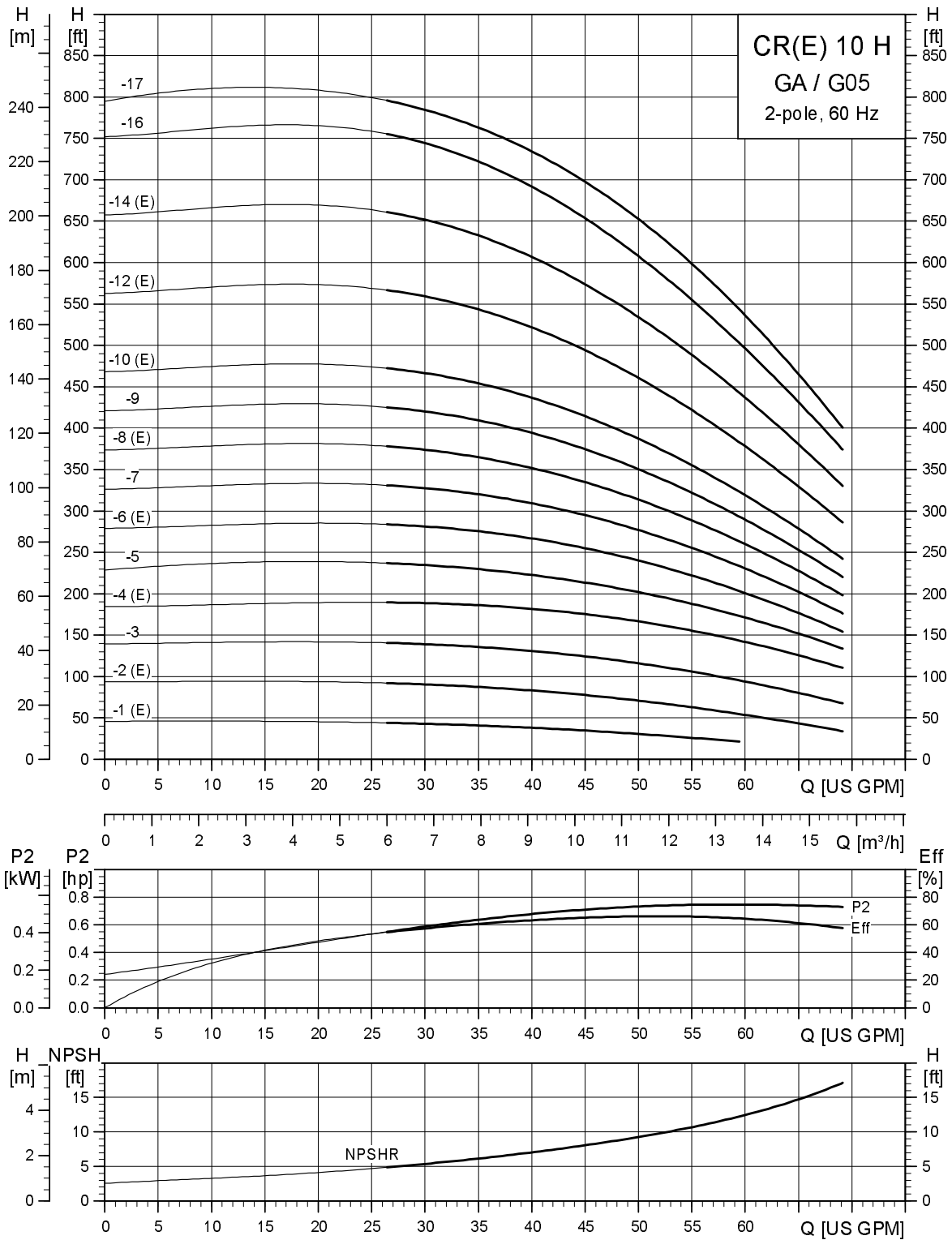

TM04 6284 0310

Dimensional sketches GA (1.5" x 1" x 6", 1.5" x 1" x 8")

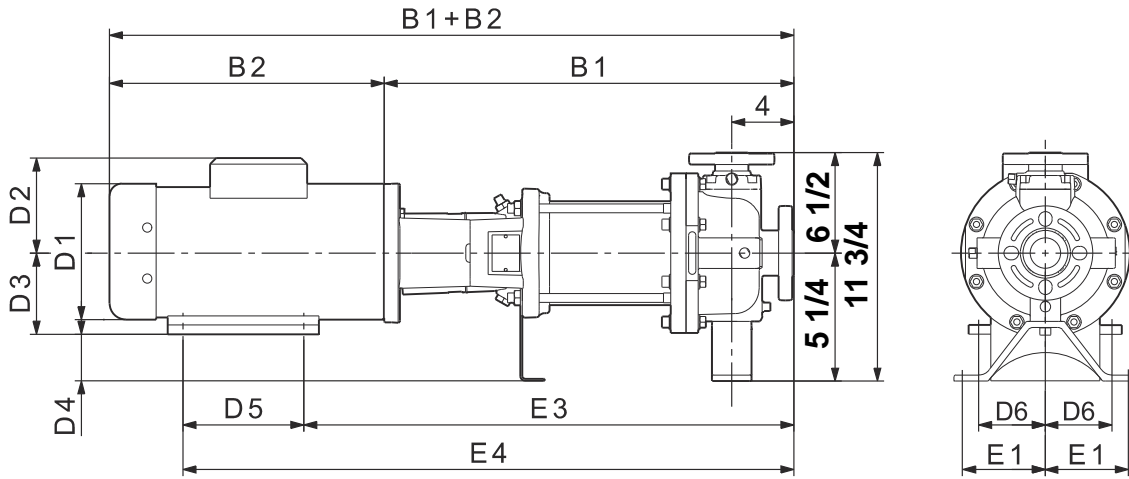

TMO4 4818 0310

Dimensions and weights GA (1.5" x 1" x 6", 1.5" x 1" x 8")

Pump type	Power [hp]	Ph	Dimensions [inches]												Ship. weight [lbs]	Dimensions [inches]			Ship. weight [lbs]			
			TEFC													ODP				MLE		
			B1	B1+B2	E1	E3	E4	D1	D2	D3	D4	D5	D6	D1		D2	B1+B2	D1		D2	B1+B2	
CR(E) 10-1 H	0.75	1	17.00	26.88	3.00	19.63	22.63	6.25	5.25	3.50	1.75	3.00	2.44	—	—	—	—	5.63	5.63	26.00	—	
		3	17.00	24.63	3.00	19.63	22.63	5.63	4.63	3.50	1.75	3.00	2.44	—	—	—	—	—	—	—	—	
CR(E) 10-2 H	1.5	1	17.00	28.63	3.00	19.63	22.63	7.25	5.75	3.50	1.75	3.00	2.44	—	—	—	—	5.63	5.63	26.00	—	
		3	17.00	25.75	3.00	19.63	22.63	5.63	4.63	3.50	1.75	3.00	2.44	—	—	—	—	7.13	6.63	29.88	—	
CR 10-3 H	3	1	20.75	35.13	3.00	23.25	27.75	8.63	6.88	4.50	0.75	4.50	3.75	—	—	—	—	—	—	—	—	
		3	20.75	34.00	3.00	23.25	27.75	7.13	4.38	4.50	0.75	4.50	3.75	—	—	—	—	—	—	—	—	
CR(E) 10-4 H	3	1	21.88	36.38	3.00	24.38	28.88	8.63	6.88	4.50	0.75	4.50	3.75	—	—	—	—	—	—	—	—	
		3	21.88	35.13	3.00	24.38	28.88	7.13	4.38	4.50	0.75	4.50	3.75	—	—	—	—	7.13	6.63	35.25	—	
CR 10-5 H	5	1	23.13	38.38	3.00	25.63	30.13	10.63	7.50	4.50	0.75	4.50	3.75	—	—	—	—	—	—	—	—	
		3	23.13	38.63	3.00	25.63	30.13	8.75	5.38	4.50	0.75	4.50	3.75	—	—	—	—	—	—	—	—	
CR(E) 10-6 H	5	1	24.25	39.50	3.00	26.75	31.25	10.63	7.50	4.50	0.75	4.50	3.75	—	—	—	—	—	—	—	—	
		3	24.25	39.75	3.00	26.75	31.25	8.75	5.38	4.50	0.75	4.50	3.75	—	—	—	—	8.75	7.50	39.75	—	
CR 10-7 H	5	1	25.50	40.75	3.00	28.00	32.50	10.63	7.50	4.50	0.75	4.50	3.75	—	—	—	—	—	—	—	—	
		3	25.50	41.00	3.00	28.00	32.50	8.75	5.38	4.50	0.75	4.50	3.75	—	—	—	—	—	—	—	—	
CR(E) 10-8 H	7.5	1	27.13	42.38	3.00	30.38	35.88	10.25	7.63	5.25	0.00	5.50	4.25	—	—	—	—	—	—	—	—	
		3	27.13	42.63	3.00	30.38	35.88	8.75	5.38	5.25	0.00	5.50	4.25	—	—	—	—	8.75	7.50	42.63	—	
CR 10-9 H	7.5	1	28.25	43.50	3.00	31.50	37.00	10.25	7.63	5.25	0.00	5.50	4.25	—	—	—	—	—	—	—	—	
		3	28.25	43.75	3.00	31.50	37.00	8.75	5.38	5.25	0.00	5.50	4.25	—	—	—	—	—	—	—	—	
CR(E) 10-10 H	7.5	1	29.50	44.75	3.00	32.75	38.25	10.25	7.63	5.25	0.00	5.50	4.25	—	—	—	—	—	—	—	—	
		3	29.50	45.00	3.00	32.75	38.25	8.75	5.38	5.25	0.00	5.50	4.25	—	—	—	—	8.75	7.50	45.00	—	
CR(E) 10-12 H	10	1	31.75	47.63	3.00	35.00	40.50	11.50	10.38	5.25	0.00	5.50	4.25	—	—	—	—	—	—	—	—	
		3	31.75	47.25	3.00	35.00	40.50	8.75	5.38	5.25	0.00	5.50	4.25	—	—	—	—	8.75	7.50	47.38	—	
CR(E) 10-14 H	10	1	34.13	50.00	3.00	37.38	42.88	11.50	10.38	5.25	0.00	5.50	4.25	—	—	—	—	—	—	—	—	
		3	34.13	49.63	3.00	37.38	42.88	8.75	5.38	5.25	0.00	5.50	4.25	—	—	—	—	8.75	7.50	49.63	—	
CR 10-16 H	15	3	37.25	55.13	3.00	41.25	49.50	10.25	8.75	6.25	-1.00	8.25	5.00	10.63	6.88	53.38	—	—	—	—	—	
CR 10-17 H	15	3	39.63	57.50	3.00	43.63	51.88	10.25	8.75	6.25	-1.00	8.25	5.00	10.63	6.88	55.75	—	—	—	—	—	

Note: Terminal box is on top of motor on 3-phase up to 10 hp. All other motors have terminal box on the side. Reference D2 dimension. Weights are based on pump with TEFC motor.

Dimensional sketches G05 (2" x 1" x 10")

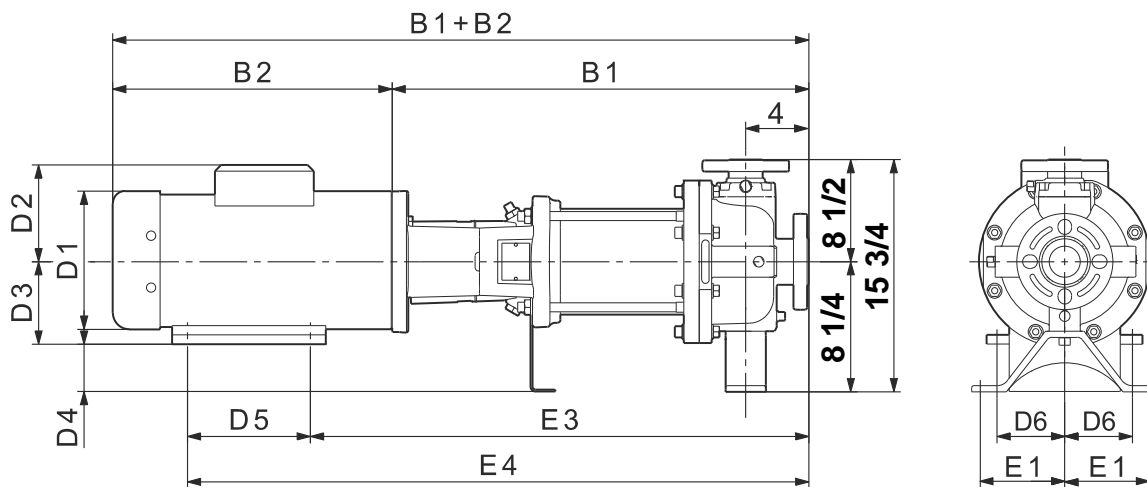

TM04 4643 0310

Dimensions and weights G05 (2" x 1" x 10")

Pump type	Power [hp]	Ph	Dimensions [inches]												Ship. weight [lbs]	Dimensions [inches]			Ship. weight [lbs]		
			TEFC						ODP			MLE									
			B1	B1+B2	E1	E3	E4	D1	D2	D3	D4	D5	D6	D1		D2	B1+B2	D1		D2	B1+B2
CR(E) 10-1 H	0.75	1	18.00	27.88	4.88	20.63	23.63	6.25	5.25	3.50	4.75	3.00	2.44	—	—	—	—	5.63	5.63	27.13	—
		3	18.00	25.63	4.88	20.63	23.63	5.63	4.63	3.50	4.75	3.00	2.44	—	—	—	—	—	—	—	—
CR(E) 10-2 H	1.5	1	18.00	29.63	4.88	20.63	23.63	7.25	5.75	3.50	4.75	3.00	2.44	—	—	—	—	5.63	5.63	27.13	—
		3	18.00	26.75	4.88	20.63	23.63	5.63	4.63	3.50	4.75	3.00	2.44	—	—	—	—	7.13	6.63	31.00	—
CR 10-3 H	3	1	21.75	36.13	4.88	24.25	28.75	8.63	6.88	4.50	3.75	4.50	3.75	—	—	—	—	—	—	—	—
		3	21.75	35.00	4.88	24.25	28.75	7.13	4.38	4.50	3.75	4.50	3.75	—	—	—	—	—	—	—	—
CR(E) 10-4 H	3	1	23.00	37.38	4.88	25.50	30.00	8.63	6.88	4.50	3.75	4.50	3.75	—	—	—	—	—	—	—	—
		3	23.00	36.25	4.88	25.50	30.00	7.13	4.38	4.50	3.75	4.50	3.75	—	—	—	—	7.13	6.63	36.25	—
CR 10-5 H	5	1	24.13	39.38	4.88	26.63	31.13	10.63	7.50	4.50	3.75	4.50	3.75	—	—	—	—	—	—	—	—
		3	24.13	39.63	4.88	26.63	31.13	8.75	5.38	4.50	3.75	4.50	3.75	—	—	—	—	—	—	—	—
CR(E) 10-6 H	5	1	25.38	40.63	4.88	27.88	32.38	10.63	7.50	4.50	3.75	4.50	3.75	—	—	—	—	—	—	—	—
		3	25.38	40.88	4.88	27.88	32.38	8.75	5.38	4.50	3.75	4.50	3.75	—	—	—	—	8.75	7.50	40.88	—
CR 10-7 H	5	1	26.50	41.75	4.88	29.00	33.50	10.63	7.50	4.50	3.75	4.50	3.75	—	—	—	—	—	—	—	—
		3	26.50	42.00	4.88	29.00	33.50	8.75	5.38	4.50	3.75	4.50	3.75	—	—	—	—	—	—	—	—
CR(E) 10-8 H	7.5	1	28.13	43.38	4.88	31.38	36.88	10.25	7.63	5.25	3.00	5.50	4.25	—	—	—	—	—	—	—	—
		3	28.13	43.63	4.88	31.38	36.88	8.75	5.38	5.25	3.00	5.50	4.25	—	—	—	—	8.75	7.50	43.63	—
CR 10-9 H	7.5	1	29.25	44.63	4.88	32.50	38.00	10.25	7.63	5.25	3.00	5.50	4.25	—	—	—	—	—	—	—	—
		3	29.25	44.75	4.88	32.50	38.00	8.75	5.38	5.25	3.00	5.50	4.25	—	—	—	—	—	—	—	—
CR(E) 10-10 H	7.5	1	30.50	45.75	4.88	33.75	39.25	10.25	7.63	5.25	3.00	5.50	4.25	—	—	—	—	—	—	—	—
		3	30.50	46.00	4.88	33.75	39.25	8.75	5.38	5.25	3.00	5.50	4.25	—	—	—	—	8.75	7.50	46.00	—
CR(E) 10-12 H	10	1	32.88	48.63	4.88	36.13	41.63	11.50	10.38	5.25	3.00	5.50	4.25	—	—	—	—	—	—	—	—
		3	32.88	48.38	4.88	36.13	41.63	8.75	5.38	5.25	3.00	5.50	4.25	—	—	—	—	8.75	7.50	48.38	—
CR(E) 10-14 H	10	1	35.25	51.00	4.88	38.50	44.00	11.50	10.38	5.25	3.00	5.50	4.25	—	—	—	—	—	—	—	—
		3	35.25	50.75	4.88	38.50	44.00	8.75	5.38	5.25	3.00	5.50	4.25	—	—	—	—	8.75	7.50	50.75	—
CR 10-16 H	15	3	38.38	56.13	4.88	42.38	50.63	10.25	8.75	6.25	2.00	8.25	5.00	10.63	6.88	54.38	—	—	—	—	—
CR 10-17 H	15	3	40.63	58.50	4.88	44.63	52.88	10.25	8.75	6.25	2.00	8.25	5.00	10.63	6.88	56.75	—	—	—	—	—

Note: Terminal box is on top of motor on 3-phase up to 10 hp. All other motors have terminal box on the side. Reference D2 dimension. Weights are based on pump with TEFC motor.

CR, CRE 15 H G22

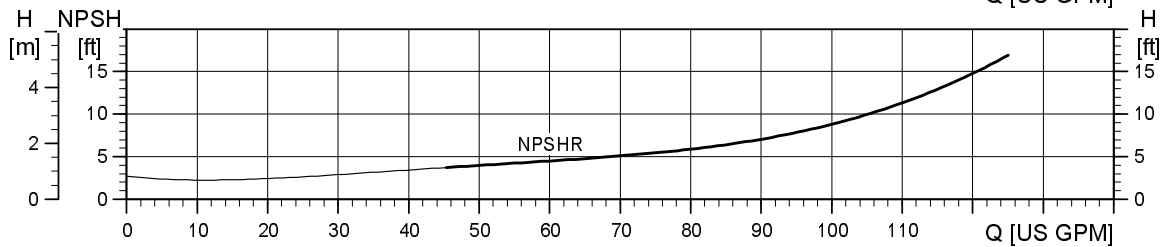
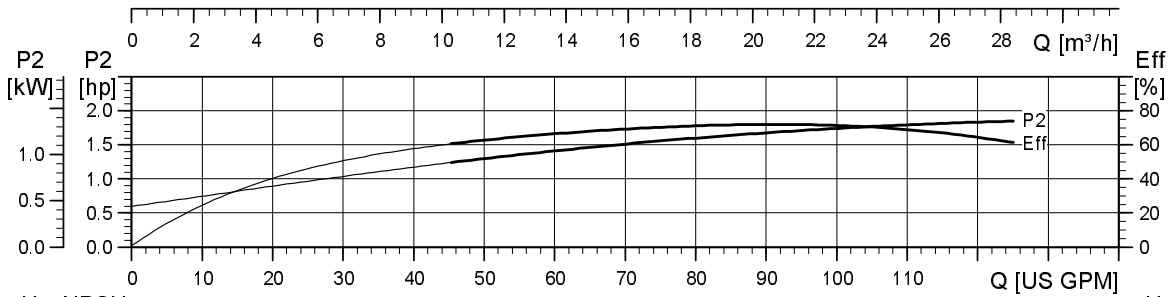
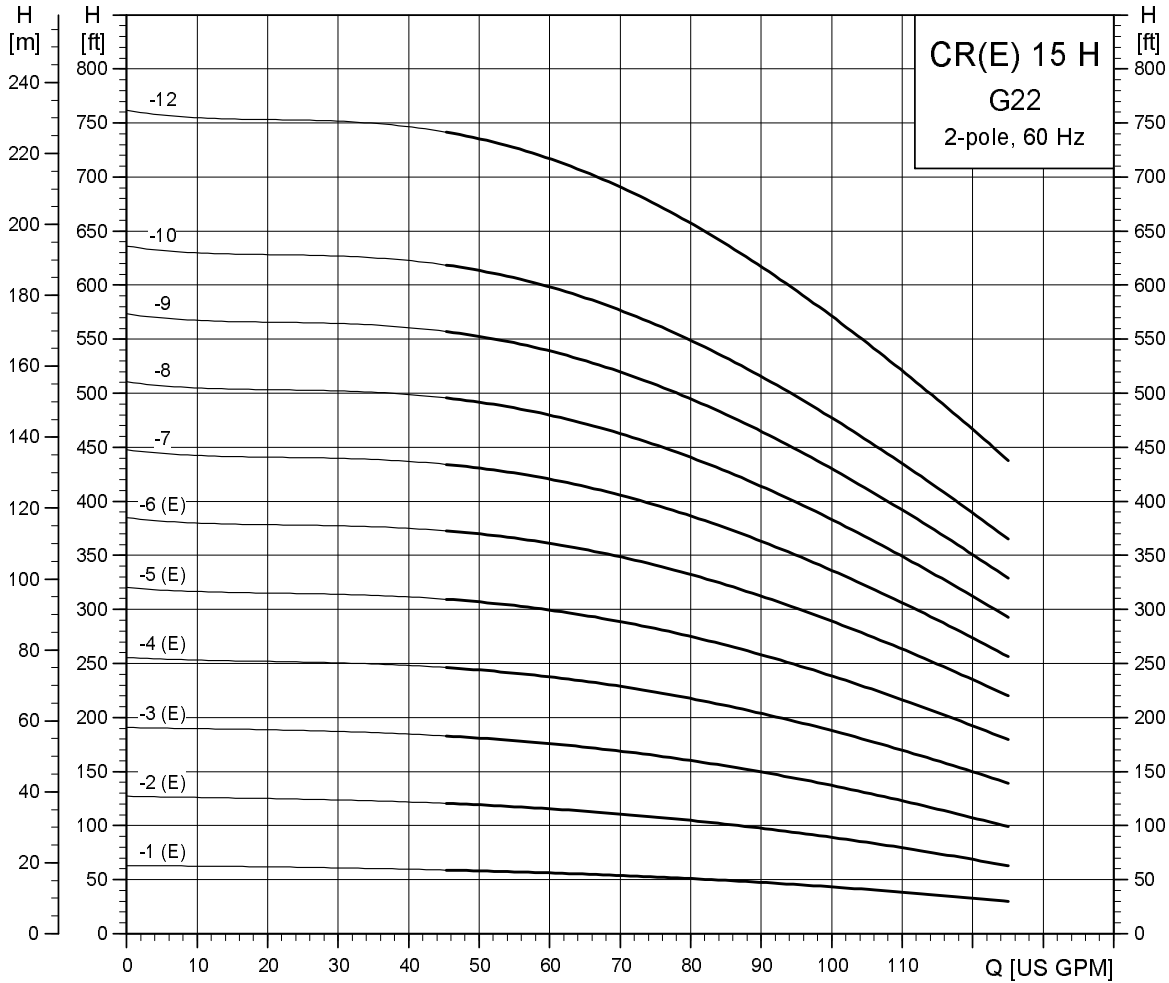

TM04 6288 0310

Dimensional sketches G22 (2" x 2")

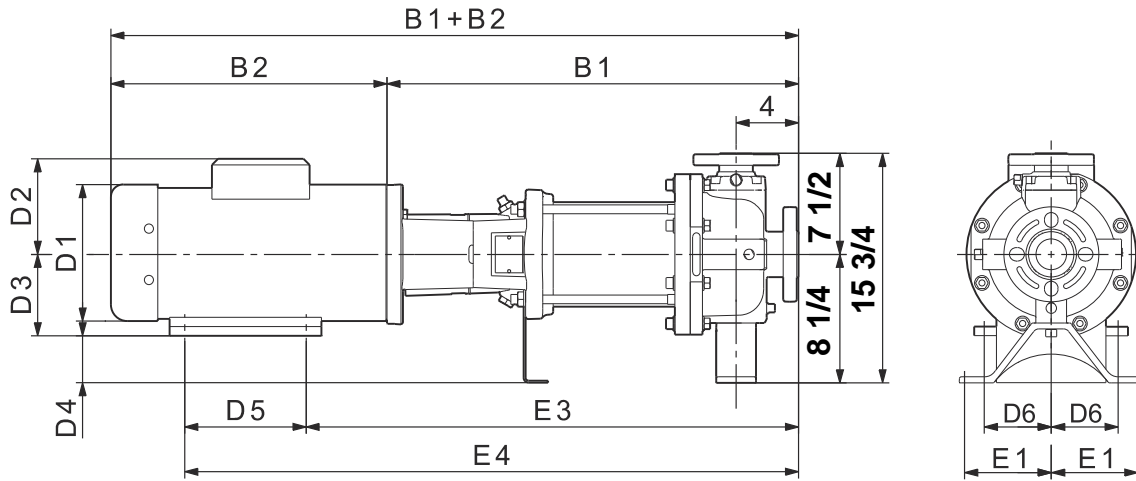

TM04 4871 0310

Dimensions and weights G22 (2" x 2")

Pump type	Power [hp]	Ph	Dimensions [inches]												Ship. weight [lbs]	Dimensions [inches]			Ship. weight [lbs]			
			TEFC													ODP				MLE		
			B1	B1+B2	E1	E3	E4	D1	D2	D3	D4	D5	D6	D1		D2	B1+B2	D1		D2	B1+B2	
CR(E) 15-1 H	2.00	1	18.13	30.75	4.88	20.75	23.75	7.25	5.75	3.50	4.75	3.00	2.44	—	—	—	—	—	—	—		
		3	18.13	29.63	4.88	20.75	23.75	7.13	4.38	3.50	4.75	3.00	2.44	—	—	—	—	7.13	6.63	31.13	—	
CR(E) 15-2 H	5.00	1	20.75	36.00	4.88	23.25	27.75	10.63	7.50	4.50	3.75	4.50	3.75	—	—	—	—	—	—	—	—	
		3	20.75	36.25	4.88	23.25	27.75	8.75	5.38	4.50	3.75	4.50	3.75	—	—	—	—	8.75	7.50	36.25	—	
CR(E) 15-3 H	5.00	1	22.50	37.75	4.88	25.00	29.50	10.63	7.50	4.50	3.75	4.50	3.75	—	—	—	—	—	—	—	—	
		3	22.50	38.00	4.88	25.00	29.50	8.75	5.38	4.50	3.75	4.50	3.75	—	—	—	—	8.75	7.50	38.00	—	
CR(E) 15-4 H	7.50	1	24.75	40.00	4.88	28.00	33.50	10.25	7.63	5.25	3.00	5.50	4.25	—	—	—	—	—	—	—	—	
		3	24.75	40.25	4.88	28.00	33.50	8.75	5.38	5.25	3.00	5.50	4.25	—	—	—	—	8.75	7.50	40.25	—	
CR(E) 15-5 H	10.00	1	26.50	42.38	4.88	29.75	35.25	11.50	10.38	5.25	3.00	5.50	4.25	—	—	—	—	—	—	—	—	
		3	26.50	42.00	4.88	29.75	35.25	8.75	5.38	5.25	3.00	5.50	4.25	—	—	—	—	8.75	7.50	42.00	—	
CR(E) 15-6 H	10.00	1	28.25	44.13	4.88	31.50	37.00	11.50	10.38	5.25	3.00	5.50	4.25	—	—	—	—	—	—	—	—	
		3	28.25	43.75	4.88	31.50	37.00	8.75	5.38	5.25	3.00	5.50	4.25	—	—	—	—	8.75	7.50	43.75	—	
CR 15-7 H	15.00	3	30.75	48.63	4.88	34.75	43.00	10.25	8.75	6.25	2.00	8.25	5.00	10.63	6.88	46.88	—	—	—	—	—	
CR 15-8 H	15.00	3	32.63	50.38	4.88	36.63	44.88	10.25	8.75	6.25	2.00	8.25	5.00	10.63	6.88	48.63	—	—	—	—	—	
CR 15-9 H	15.00	3	34.38	52.25	4.88	38.38	46.63	10.25	8.75	6.25	2.00	8.25	5.00	10.63	6.88	50.38	—	—	—	—	—	
CR 15-10 H	20.00	3	36.13	53.75	4.88	40.13	48.38	10.25	8.88	6.25	2.00	8.25	5.00	11.50	9.13	55.50	—	—	—	—	—	
CR 15-12 H	25.00	3	38.88	60.50	4.88	43.38	52.88	13.38	12.13	7.00	1.25	9.50	5.50	11.50	9.13	59.38	—	—	—	—	—	

Note: Terminal box is on top of motor on 3-phase up to 10 hp. All other motors have terminal box on the side. Reference D2 dimension. Weights are based on pump with TEFC motor.

CR, CRE 15 H GA/G05

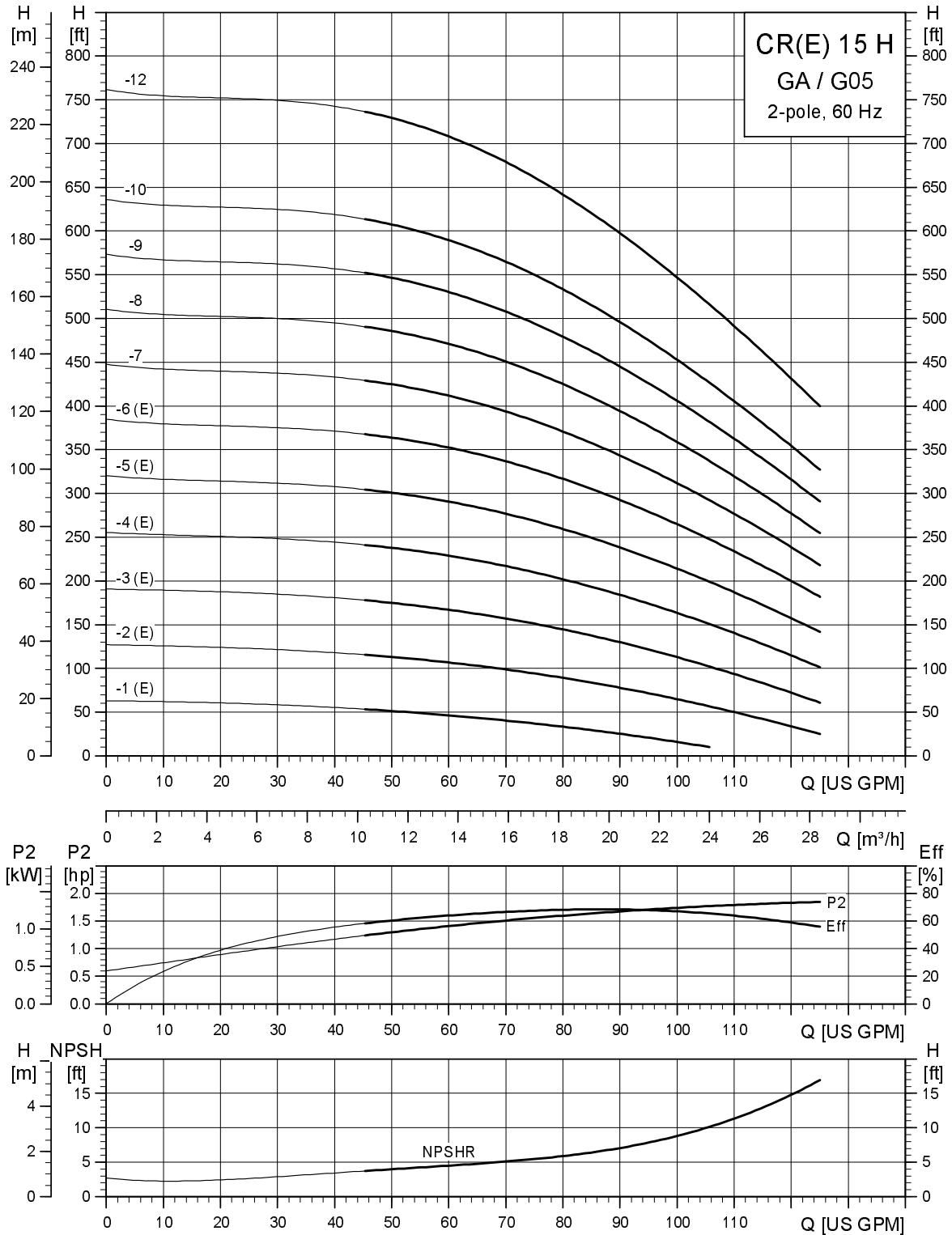

TM04 6286 0310

Dimensional sketches GA (1.5" x 1" x 6", 1.5" x 1" x 8")

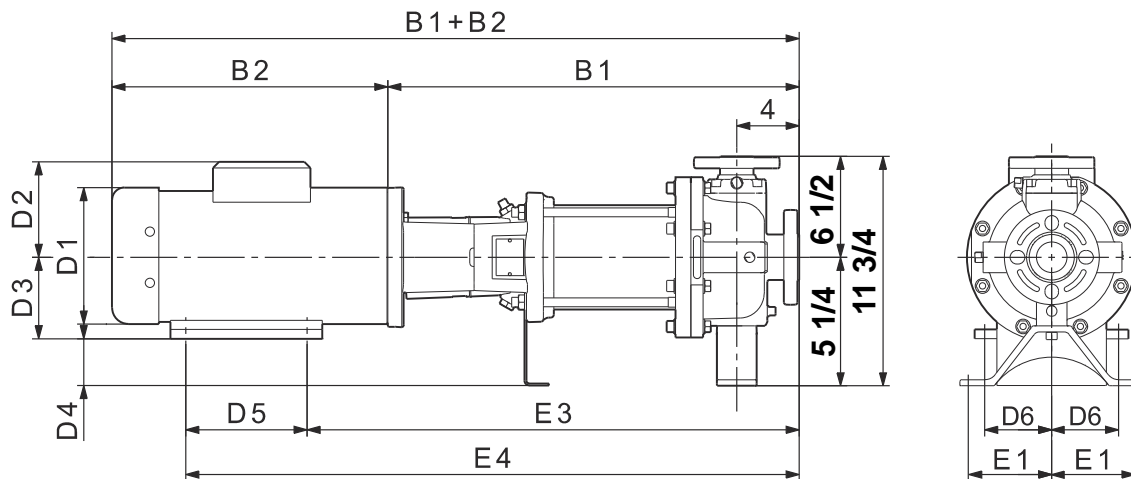

TM04 4818 0310

Dimensions and weights GA (1.5" x 1" x 6", 1.5" x 1" x 8")

Pump type	Power [hp]	Phases	Dimensions [inches]											Ship. weight [lbs]	Dimensions			Ship. weight [lbs]						
			TEFC												ODP				MLE					
			B1	B1+B	E1	E3	E4	D1	D2	D3	D4	D5	D6		D1	D2	B1+B		D1	D2	B1+B			
CR(E) 15-1 H	2.00	1	18.13	30.75	3.00	20.75	23.75	7.25	5.75	3.50	1.75	3.00	2.44	—	—	—	—	—	—	—	—	—	—	—
		3	18.13	29.63	3.00	20.75	23.75	7.13	4.38	3.50	1.75	3.00	2.44	—	—	—	—	7.13	6.63	31.13	—	—	—	—
CR(E) 15-2 H	5.00	1	20.75	36.00	3.00	23.25	27.75	10.63	7.50	4.50	0.75	4.50	3.75	—	—	—	—	—	—	—	—	—	—	—
		3	20.75	36.25	3.00	23.25	27.75	8.75	5.38	4.50	0.75	4.50	3.75	—	—	—	—	8.75	7.50	36.25	—	—	—	—
CR(E) 15-3 H	5.00	1	22.50	37.75	3.00	25.00	29.50	10.63	7.50	4.50	0.75	4.50	3.75	—	—	—	—	—	—	—	—	—	—	—
		3	22.50	38.00	3.00	25.00	29.50	8.75	5.38	4.50	0.75	4.50	3.75	—	—	—	—	8.75	7.50	38.00	—	—	—	—
CR(E) 15-4 H	7.50	1	24.75	40.00	3.00	28.00	33.50	10.25	7.63	5.25	0.00	5.50	4.25	—	—	—	—	—	—	—	—	—	—	—
		3	24.75	40.25	3.00	28.00	33.50	8.75	5.38	5.25	0.00	5.50	4.25	—	—	—	—	8.75	7.50	40.25	—	—	—	—
CR(E) 15-5 H	10.00	1	26.50	42.38	3.00	29.75	35.25	11.50	10.38	5.25	0.00	5.50	4.25	—	—	—	—	—	—	—	—	—	—	—
		3	26.50	42.00	3.00	29.75	35.25	8.75	5.38	5.25	0.00	5.50	4.25	—	—	—	—	8.75	7.50	42.00	—	—	—	—
CR(E) 15-6 H	10.00	1	28.25	44.13	3.00	31.50	37.00	11.50	10.38	5.25	0.00	5.50	4.25	—	—	—	—	—	—	—	—	—	—	—
		3	28.25	43.75	3.00	31.50	37.00	8.75	5.38	5.25	0.00	5.50	4.25	—	—	—	—	8.75	7.50	43.75	—	—	—	—
CR 15-7 H	15.00	3	30.75	48.63	3.00	34.75	43.00	10.25	8.75	6.25	-1.00	8.25	5.00	10.63	6.88	46.88	—	—	—	—	—	—	—	—
CR 15-8 H	15.00	3	32.63	50.38	3.00	36.63	44.88	10.25	8.75	6.25	-1.00	8.25	5.00	10.63	6.88	48.63	—	—	—	—	—	—	—	—
CR 15-9 H	15.00	3	34.38	52.25	3.00	38.38	46.63	10.25	8.75	6.25	-1.00	8.25	5.00	10.63	6.88	50.38	—	—	—	—	—	—	—	—
CR 15-10 H	20.00	3	36.13	53.75	3.00	40.13	48.38	10.25	8.88	6.25	-1.00	8.25	5.00	11.50	9.13	55.50	—	—	—	—	—	—	—	—
CR 15-12 H	25.00	3	38.88	60.50	3.00	43.38	52.88	13.38	12.13	7.00	-1.75	9.50	5.50	11.50	9.13	59.38	—	—	—	—	—	—	—	—

Note: Terminal box is on top of motor on 3-phase up to 10 hp. All other motors have terminal box on the side. Reference D2 dimension. Weights are based on pump with TEFC motor.

Dimensional sketches G05 (2" x 1" x 10")

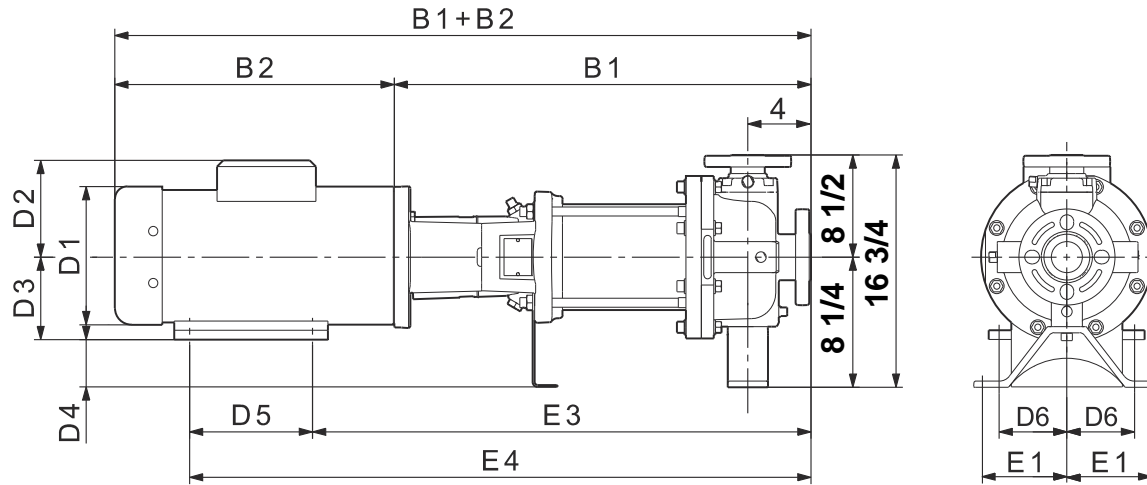

TM04 4643 0310

Dimensions and weights G05 (2" x 1" x 10")

Pump type	Power [hp]	Ph	Dimensions [inches]												Ship. weight [lbs]	Dimensions [inches]			Ship. weight [lbs]			
			TEFC													ODP				MLE		
			B1	B1+B2	E1	E3	E4	D1	D2	D3	D4	D5	D6	D1		D2	B1+B2	D1		D2	B1+B2	
CR(E) 15-1 H	2	1	18.13	30.75	4.88	20.75	23.75	7.25	5.75	3.50	4.75	3.00	2.44	—	—	—	—	—	—	—	—	
		3	18.13	29.63	4.88	20.75	23.75	7.13	4.38	3.50	4.75	3.00	2.44	—	—	—	—	7.13	6.63	31.13	—	
CR(E) 15-2 H	5	1	20.75	36.00	4.88	23.25	27.75	10.63	7.50	4.50	3.75	4.50	3.75	—	—	—	—	—	—	—	—	
		3	20.75	36.25	4.88	23.25	27.75	8.75	5.38	4.50	3.75	4.50	3.75	—	—	—	—	8.75	7.50	36.25	—	
CR(E) 15-3 H	5	1	22.50	37.75	4.88	25.00	29.50	10.63	7.50	4.50	3.75	4.50	3.75	—	—	—	—	—	—	—	—	
		3	22.50	38.00	4.88	25.00	29.50	8.75	5.38	4.50	3.75	4.50	3.75	—	—	—	—	8.75	7.50	38.00	—	
CR(E) 15-4 H	7.5	1	24.75	40.00	4.88	28.00	33.50	10.25	7.63	5.25	3.00	5.50	4.25	—	—	—	—	—	—	—	—	
		3	24.75	40.25	4.88	28.00	33.50	8.75	5.38	5.25	3.00	5.50	4.25	—	—	—	—	8.75	7.50	40.25	—	
CR(E) 15-5 H	10	1	26.50	42.38	4.88	29.75	35.25	11.50	10.38	5.25	3.00	5.50	4.25	—	—	—	—	—	—	—	—	
		3	26.50	42.00	4.88	29.75	35.25	8.75	5.38	5.25	3.00	5.50	4.25	—	—	—	—	8.75	7.50	42.00	—	
CR(E) 15-6 H	10	1	28.25	44.13	4.88	31.50	37.00	11.50	10.38	5.25	3.00	5.50	4.25	—	—	—	—	—	—	—	—	
		3	28.25	43.75	4.88	31.50	37.00	8.75	5.38	5.25	3.00	5.50	4.25	—	—	—	—	8.75	7.50	43.75	—	
CR 15-7 H	15	3	30.75	48.63	4.88	34.75	43.00	10.25	8.75	6.25	2.00	8.25	5.00	10.63	6.88	46.88	—	—	—	—	—	
CR 15-8 H	15	3	32.63	50.38	4.88	36.63	44.88	10.25	8.75	6.25	2.00	8.25	5.00	10.63	6.88	48.63	—	—	—	—	—	
CR 15-9 H	15	3	34.38	52.25	4.88	38.38	46.63	10.25	8.75	6.25	2.00	8.25	5.00	10.63	6.88	50.38	—	—	—	—	—	
CR 15-10 H	20	3	36.13	53.75	4.88	40.13	48.38	10.25	8.88	6.25	2.00	8.25	5.00	11.50	9.13	55.50	—	—	—	—	—	
CR 15-12 H	25	3	38.88	60.50	4.88	43.38	52.88	13.38	12.13	7.00	1.25	9.50	5.50	11.50	9.13	59.38	—	—	—	—	—	

Note: Terminal box is on top of motor on 3-phase up to 10 hp. All other motors have terminal box on the side. Reference D2 dimension. Weights are based on pump with TEFC motor.

CR, CRE 15 H GB

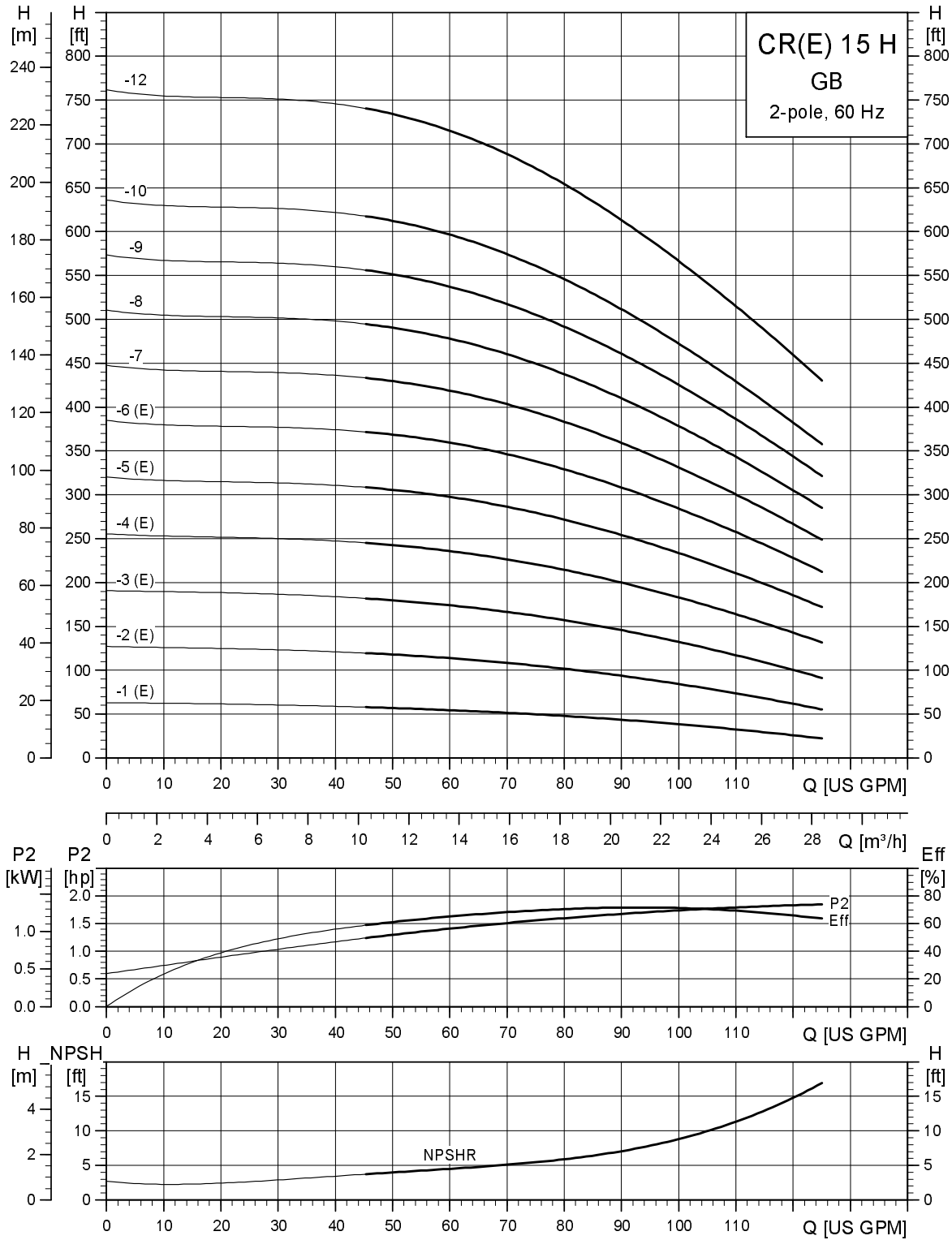

TM04 6287 0310

Dimensional sketches GB (3" x 1.5" x 6", 3" x 1.5" x 8")

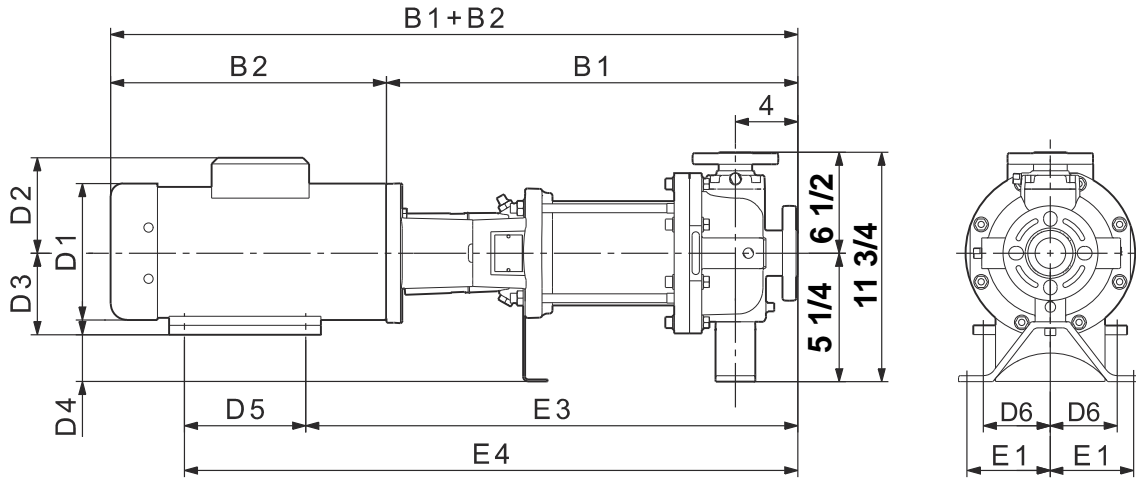

TM04 4818 0310

Dimensions and weights GB (3" x 1.5" x 6", 3" x 1.5" x 8")

Pump type	Power [hp]	Ph	Dimensions [inches]												Ship. weight [lbs]	Dimensions [inches]			Ship. weight [lbs]			
			TEFC													ODP				MLE		
			B1	B1+B2	E1	E3	E4	D1	D2	D3	D4	D5	D6	D1		D2	B1+B2	D1		D2	B1+B2	
CR(E) 15-1 H	2	1	19.13	31.75	3.00	21.75	24.75	7.25	5.75	3.50	1.75	3.00	2.44	—	—	—	—	—	—	—		
		3	19.13	30.63	3.00	21.75	24.75	7.13	4.38	3.50	1.75	3.00	2.44	—	—	—	—	7.13	6.63	32.13	—	
CR(E) 15-2 H	5	1	21.75	37.00	3.00	24.25	28.75	10.63	7.50	4.50	0.75	4.50	3.75	—	—	—	—	—	—	—		
		3	21.75	37.25	3.00	24.25	28.75	8.75	5.38	4.50	0.75	4.50	3.75	—	—	—	—	8.75	7.50	37.25	—	
CR(E) 15-3 H	5	1	23.50	38.88	3.00	26.00	30.50	10.63	7.50	4.50	0.75	4.50	3.75	—	—	—	—	—	—	—		
		3	23.50	39.00	3.00	26.00	30.50	8.75	5.38	4.50	0.75	4.50	3.75	—	—	—	—	8.75	7.50	39.00	—	
CR(E) 15-4 H	7.5	1	25.75	41.00	3.00	29.00	34.50	10.25	7.63	5.25	0.00	5.50	4.25	—	—	—	—	—	—	—		
		3	25.75	41.25	3.00	29.00	34.50	8.75	5.38	5.25	0.00	5.50	4.25	—	—	—	—	8.75	7.50	41.25	—	
CR(E) 15-5 H	10	1	27.50	43.38	3.00	30.75	36.25	11.50	10.38	5.25	0.00	5.50	4.25	—	—	—	—	—	—	—		
		3	27.50	43.00	3.00	30.75	36.25	8.75	5.38	5.25	0.00	5.50	4.25	—	—	—	—	8.75	7.50	43.00	—	
CR(E) 15-6 H	10	1	29.25	45.13	3.00	32.50	38.00	11.50	10.38	5.25	0.00	5.50	4.25	—	—	—	—	—	—	—		
		3	29.25	44.75	3.00	32.50	38.00	8.75	5.38	5.25	0.00	5.50	4.25	—	—	—	—	8.75	7.50	44.75	—	
CR 15-7 H	15	3	31.88	49.63	3.00	35.88	44.13	10.25	8.75	6.25	-1.00	8.25	5.00	10.63	6.88	47.88	—	—	—	—		
CR 15-8 H	15	3	33.63	51.50	3.00	37.63	45.88	10.25	8.75	6.25	-1.00	8.25	5.00	10.63	6.88	49.63	—	—	—	—		
CR 15-9 H	15	3	35.38	53.25	3.00	39.38	47.63	10.25	8.75	6.25	-1.00	8.25	5.00	10.63	6.88	51.38	—	—	—	—		
CR 15-10 H	20	3	37.13	54.75	3.00	41.13	49.38	10.25	8.88	6.25	-1.00	8.25	5.00	11.50	9.13	56.63	—	—	—	—		
CR 15-12 H	25	3	39.88	61.63	3.00	44.38	53.88	13.38	12.13	7.00	-1.75	9.50	5.50	11.50	9.13	60.38	—	—	—	—		

Note: Terminal box is on top of motor on 3-phase up to 10 hp. All other motors have terminal box on the side. Reference D2 dimension. Weights are based on pump with TEFC motor.

CR, CRE 20 H G22

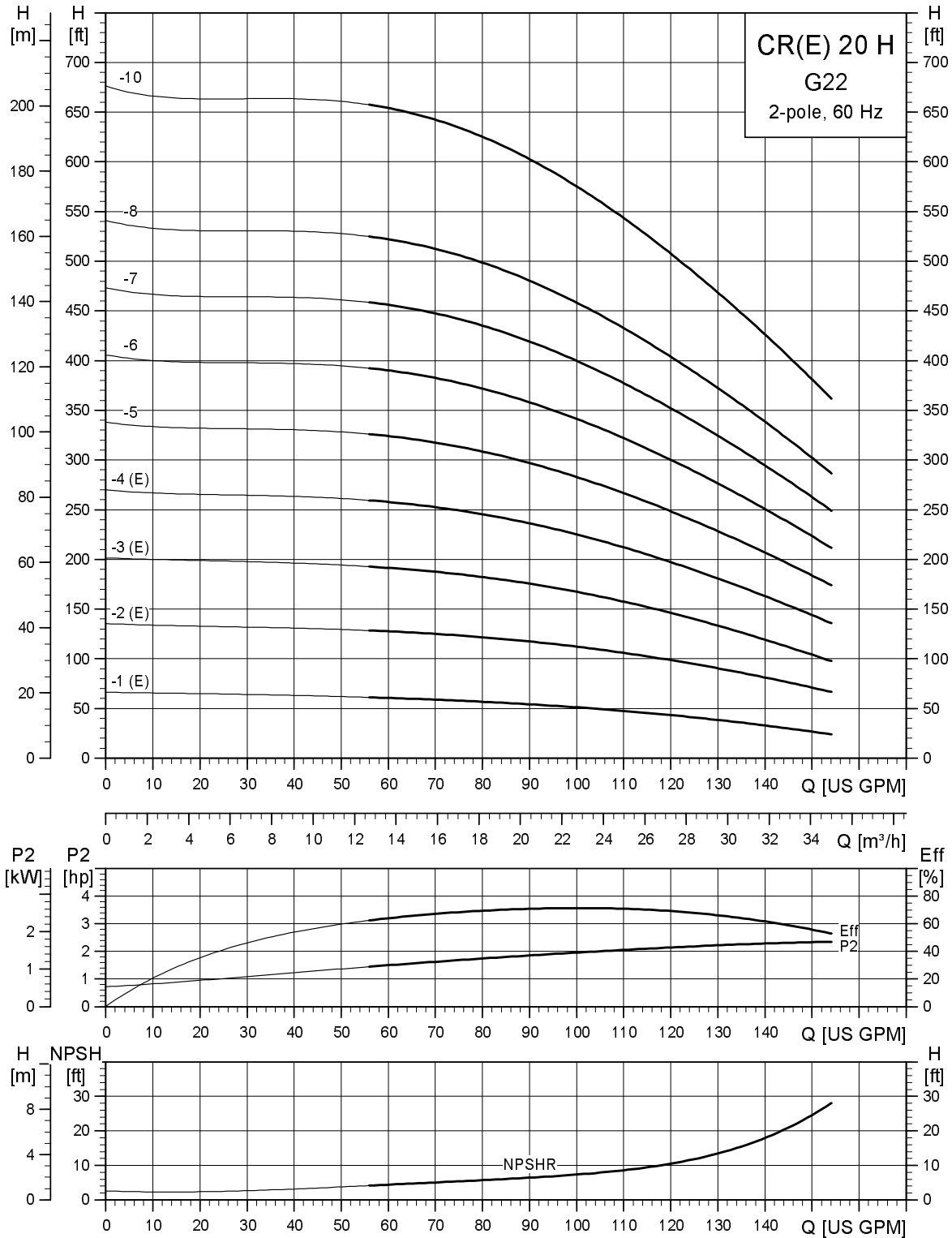

TM04 6291 0310

Dimensional sketches G22 (2" x 2")

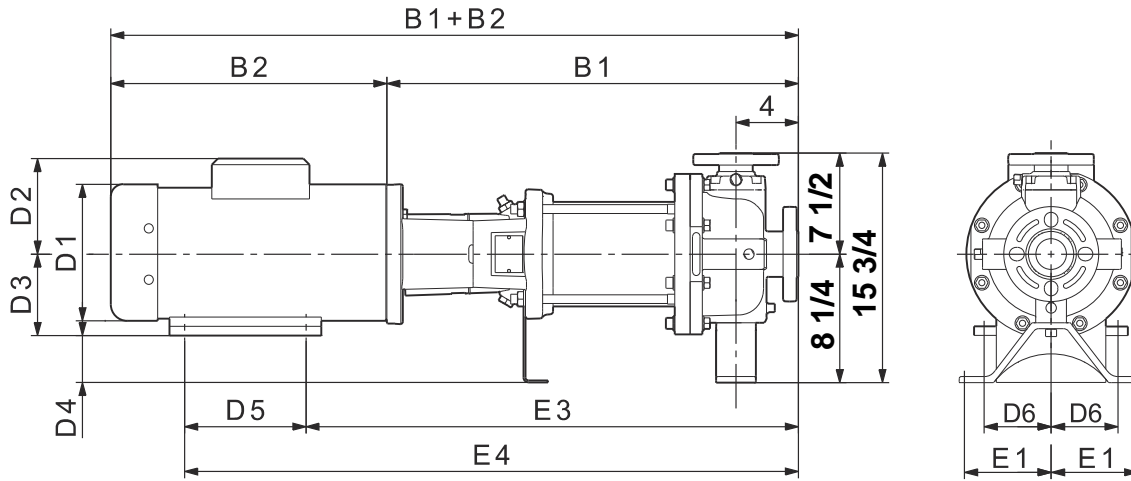

TM04 4871 0310

Dimensions and weights G22 (2" x 2")

Pump type	Power [hp]	Ph	Dimensions [inches]											Ship. weight [lbs]	Dimensions [inches]			Ship. weight [lbs]			
			TEFC												ODP				MLE		
			B1	B1+B	E1	E3	E4	D1	D2	D3	D4	D5	D6		D1	D2	B1+B		D1	D2	B1+B
CR(E) 20-1 H	3	1	20.75	35.13	4.88	23.25	27.75	8.63	6.88	4.50	3.75	4.50	3.75	—	—	—	—	—	—	—	
		3	20.75	34.00	4.88	23.25	27.75	7.13	4.38	4.50	3.75	4.50	3.75	—	—	—	—	7.13	6.63	34.00	—
CR(E) 20-2 H	5	1	20.75	36.00	4.88	23.25	27.75	10.63	7.50	4.50	3.75	4.50	3.75	—	—	—	—	—	—	—	
		3	20.75	36.25	4.88	23.25	27.75	8.75	5.38	4.50	3.75	4.50	3.75	—	—	—	—	8.75	7.50	36.25	—
CR(E) 20-3 H	7.5	1	23.00	38.25	4.88	26.25	31.75	10.25	7.63	5.25	3.00	5.50	4.25	—	—	—	—	—	—	—	
		3	23.00	38.50	4.88	26.25	31.75	8.75	5.38	5.25	3.00	5.50	4.25	—	—	—	—	8.75	7.50	38.50	—
CR(E) 20-4 H	10	1	24.75	40.50	4.88	28.00	33.50	11.50	10.38	5.25	3.00	5.50	4.25	—	—	—	—	—	—	—	
		3	24.75	40.25	4.88	28.00	33.50	8.75	5.38	5.25	3.00	5.50	4.25	—	—	—	—	8.75	7.50	40.25	—
CR 20-5 H	15	3	27.25	45.13	4.88	31.25	39.50	10.25	8.75	6.25	2.00	8.25	5.00	10.63	6.88	43.38	—	—	—	—	
CR 20-6 H	15	3	29.00	46.88	4.88	33.00	41.25	10.25	8.75	6.25	2.00	8.25	5.00	10.63	6.88	45.13	—	—	—	—	
CR 20-7 H	20	3	30.75	48.38	4.88	34.75	43.00	10.25	8.88	6.25	2.00	8.25	5.00	11.50	9.13	50.25	—	—	—	—	
CR 20-8 H	20	3	32.63	50.13	4.88	36.63	44.88	10.25	8.88	6.25	2.00	8.25	5.00	11.50	9.13	52.00	—	—	—	—	
CR 20-10 H	25	3	35.25	57.00	4.88	39.75	49.25	13.38	12.13	7.00	1.25	9.50	5.50	11.50	9.13	55.88	—	—	—	—	

Note: Terminal box is on top of motor on 3-phase up to 10 hp. All other motors have terminal box on the side. Reference D2 dimension. Weights are based on pump with TEFC motor.

CR, CRE 20 H GA/G05

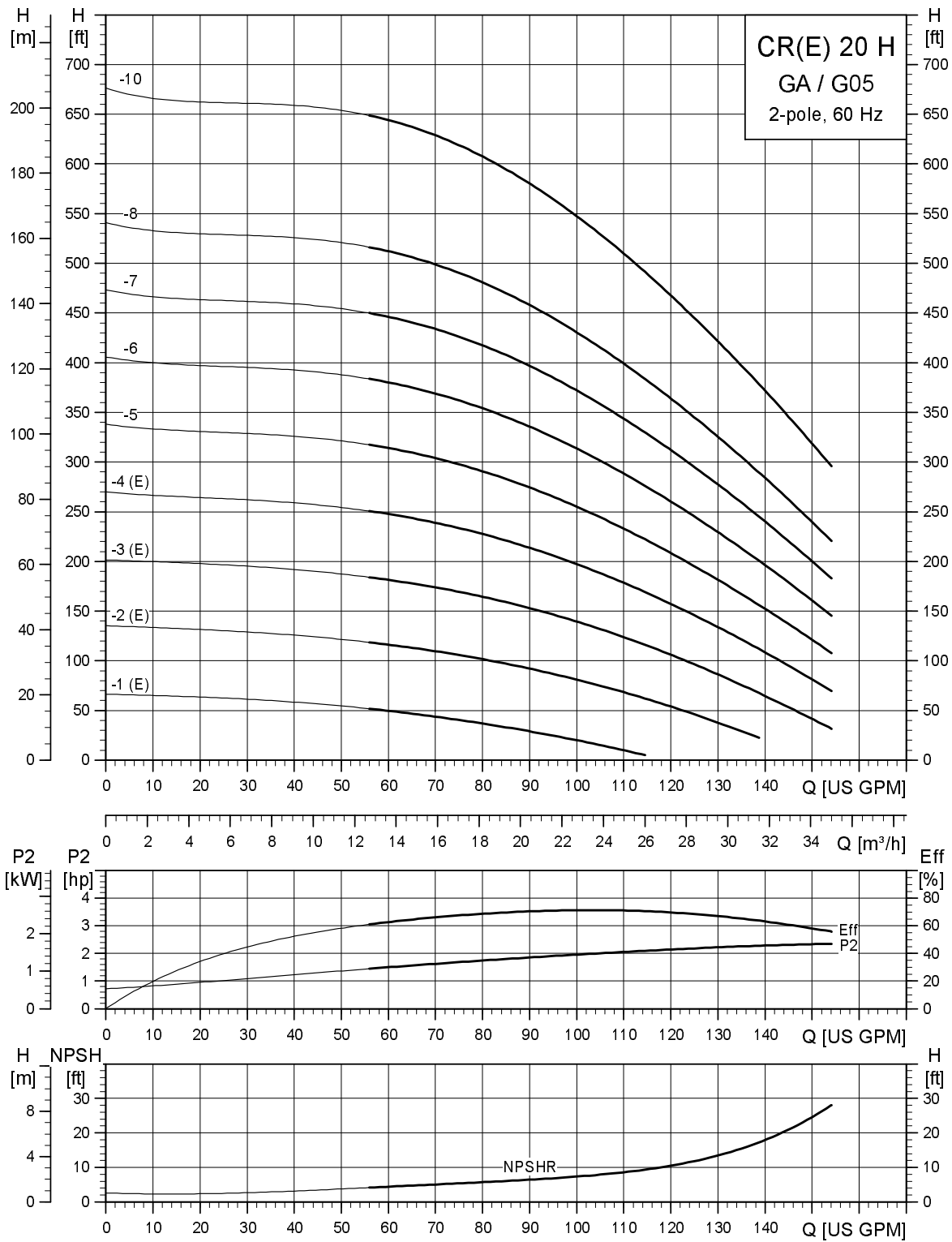

TM04 6289 0310

Dimensional sketches GA (1.5" x 1" x 6", 1.5" x 1" x 8")

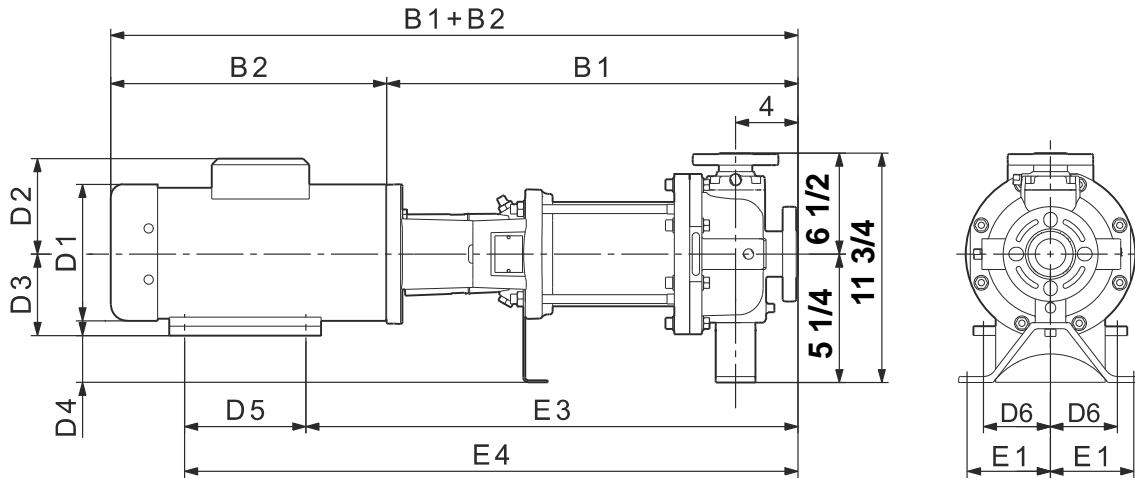

TM04 4818 0310

Dimensions and weights GA (1.5" x 1" x 6", 1.5" x 1" x 8")

Pump type	Power [hp]	Ph	Dimensions [inches]											Ship. weight [lbs]	Dimensions [inches]			Ship. weight [lbs]			
			TEFC												ODP				MLE		
			B1	B1+B2	E1	E3	E4	D1	D2	D3	D4	D5	D6		D1	D2	B1+B2		D1	D2	B1+B2
CR(E) 20-1 H	3	1	20.75	35.13	3.0	23.25	27.75	8.63	6.88	4.50	0.75	4.50	3.75	—	—	—	—	—	—	—	
		3	20.75	34.00	3.0	23.25	27.75	7.13	4.38	4.50	0.75	4.50	3.75	—	—	—	—	7.13	6.63	34.00	—
CR(E) 20-2 H	5	1	20.75	36.00	3.0	23.25	27.75	10.63	7.50	4.50	0.75	4.50	3.75	—	—	—	—	—	—	—	
		3	20.75	36.25	3.0	23.25	27.75	8.75	5.38	4.50	0.75	4.50	3.75	—	—	—	—	8.75	7.50	36.25	—
CR(E) 20-3 H	7.5	1	23.00	38.25	3.0	26.25	31.75	10.25	7.63	5.25	0.00	5.50	4.25	—	—	—	—	—	—	—	
		3	23.00	38.50	3.0	26.25	31.75	8.75	5.38	5.25	0.00	5.50	4.25	—	—	—	—	8.75	7.50	38.50	—
CR(E) 20-4 H	10	1	24.75	40.50	3.0	28.00	33.50	11.50	10.38	5.25	0.00	5.50	4.25	—	—	—	—	—	—	—	
		3	24.75	40.25	3.0	28.00	33.50	8.75	5.38	5.25	0.00	5.50	4.25	—	—	—	—	8.75	7.50	40.25	—
CR 20-5 H	15	3	27.25	45.13	3.0	31.25	39.50	10.25	8.75	6.25	-1.00	8.25	5.00	10.63	6.88	43.38	—	—	—	—	
CR 20-6 H	15	3	29.00	46.88	3.0	33.00	41.25	10.25	8.75	6.25	-1.00	8.25	5.00	10.63	6.88	45.13	—	—	—	—	
CR 20-7 H	20	3	30.75	48.38	3.0	34.75	43.00	10.25	8.88	6.25	-1.00	8.25	5.00	11.50	9.13	50.25	—	—	—	—	
CR 20-8 H	20	3	32.63	50.13	3.0	36.63	44.88	10.25	8.88	6.25	-1.00	8.25	5.00	11.50	9.13	52.00	—	—	—	—	
CR 20-10 H	25	3	35.25	57.00	3.0	39.75	49.25	13.38	12.13	7.00	-1.75	9.50	5.50	11.50	9.13	55.88	—	—	—	—	

Note: Terminal box is on top of motor on 3-phase up to 10 hp. All other motors have terminal box on the side. Reference D2 dimension. Weights are based on pump with TEFC motor.

Dimensional sketches G05 (2" x 1" x 10")

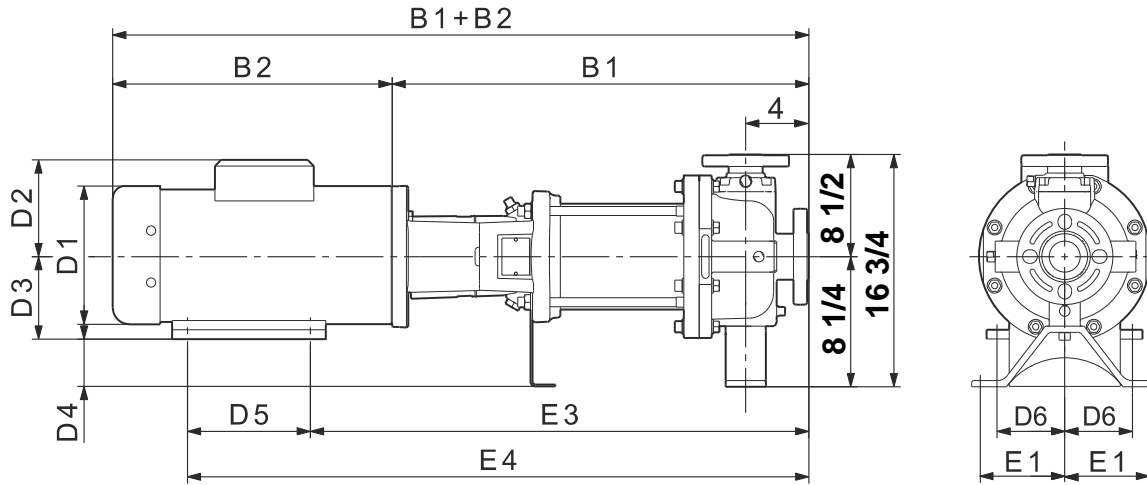

TM04 4643 0310

Dimensions and weights G05 (2" x 1" x 10")

Pump type	Power [hp]	Ph	Dimensions [inches]										Ship. weight [lbs]	Dimensions [inches]			Ship. weight [lbs]				
			TEFC											ODP				MLE			
			B1	B1+B	E1	E3	E4	D1	D2	D3	D4	D5		D6	D1	D2		B1+B	D1	D2	B1+B
CR(E) 20-1 H	3	1	20.75	35.13	4.88	23.25	27.75	8.63	6.88	4.50	3.75	4.50	3.75	—	—	—	—	—	—	—	—
		3	20.75	34.00	4.88	23.25	27.75	7.13	4.38	4.50	3.75	4.50	3.75	—	—	—	—	7.13	6.63	34.00	—
CR(E) 20-2 H	5	1	20.75	36.00	4.88	23.25	27.75	10.63	7.50	4.50	3.75	4.50	3.75	—	—	—	—	—	—	—	—
		3	20.75	36.25	4.88	23.25	27.75	8.75	5.38	4.50	3.75	4.50	3.75	—	—	—	—	8.75	7.50	36.25	—
CR(E) 20-3 H	7.5	1	23.00	38.25	4.88	26.25	31.75	10.25	7.63	5.25	3.00	5.50	4.25	—	—	—	—	—	—	—	—
		3	23.00	38.50	4.88	26.25	31.75	8.75	5.38	5.25	3.00	5.50	4.25	—	—	—	—	8.75	7.50	38.50	—
CR(E) 20-4 H	10	1	24.75	40.50	4.88	28.00	33.50	11.50	10.38	5.25	3.00	5.50	4.25	—	—	—	—	—	—	—	—
		3	24.75	40.25	4.88	28.00	33.50	8.75	5.38	5.25	3.00	5.50	4.25	—	—	—	—	8.75	7.50	40.25	—
CR 20-5 H	15	3	27.25	45.13	4.88	31.25	39.50	10.25	8.75	6.25	2.00	8.25	5.00	10.63	6.88	43.38	—	—	—	—	—
CR 20-6 H	15	3	29.00	46.88	4.88	33.00	41.25	10.25	8.75	6.25	2.00	8.25	5.00	10.63	6.88	45.13	—	—	—	—	—
CR 20-7 H	20	3	30.75	48.38	4.88	34.75	43.00	10.25	8.88	6.25	2.00	8.25	5.00	11.50	9.13	50.25	—	—	—	—	—
CR 20-8 H	20	3	32.63	50.13	4.88	36.63	44.88	10.25	8.88	6.25	2.00	8.25	5.00	11.50	9.13	52.00	—	—	—	—	—
CR 20-10 H	25	3	35.25	57.00	4.88	39.75	49.25	13.38	12.13	7.00	1.25	9.50	5.50	11.50	9.13	55.88	—	—	—	—	—

Note: Terminal box is on top of motor on 3-phase up to 10 hp. All other motors have terminal box on the side. Reference D2 dimension. Weights are based on pump with TEFC motor.

CR, CRE 20 H GB

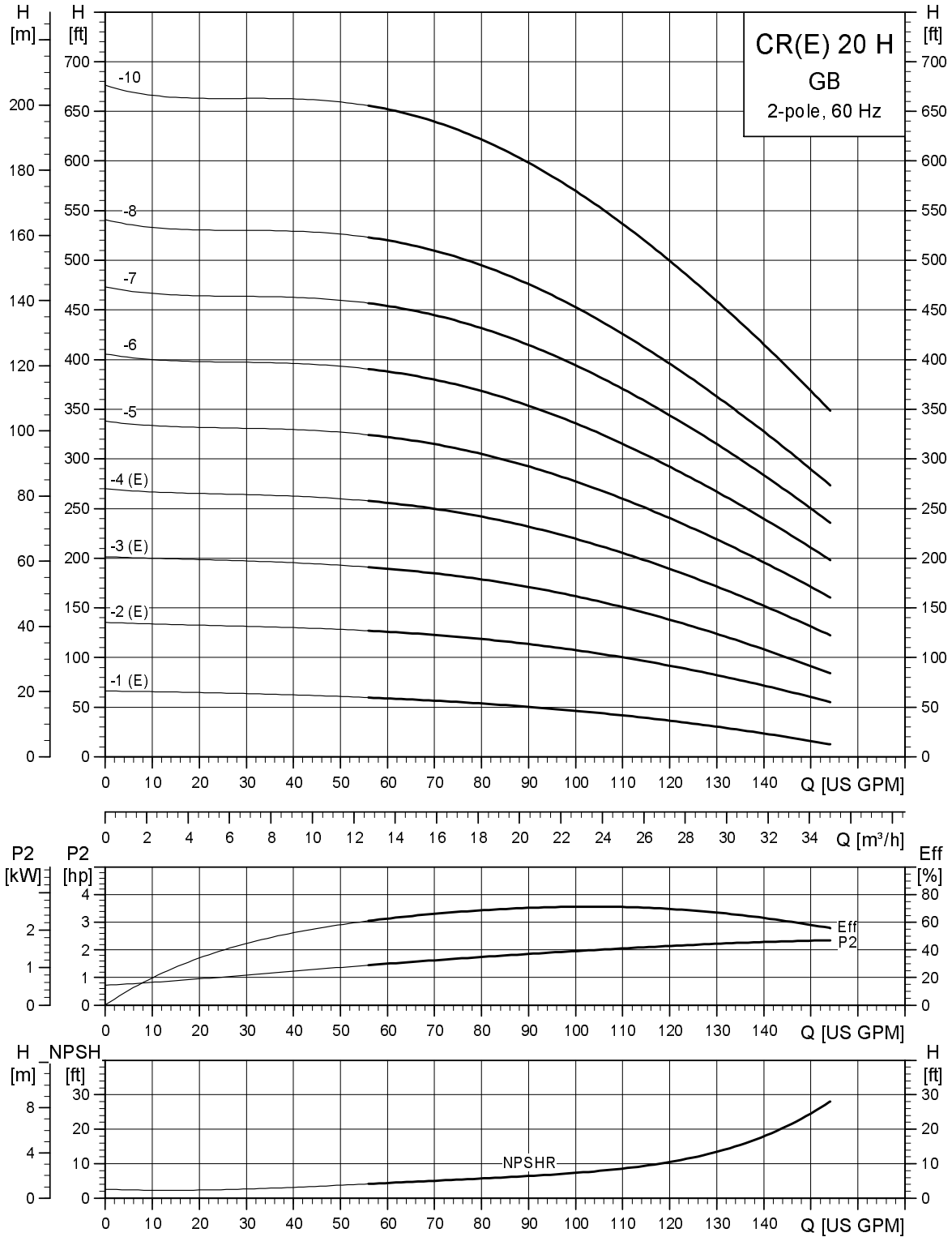

TM04 6290 0310

Dimensional sketches GB (3" x 1.5" x 6", 3" x 1.5" x 8")

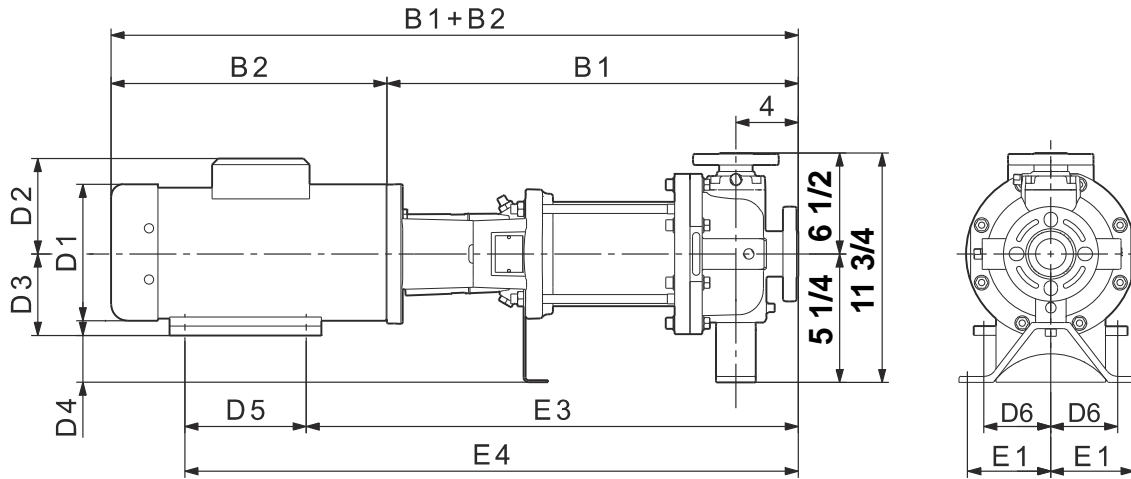

TMO4 4818 0310

Dimensions and weights GB (3" x 1.5" x 6", 3" x 1.5" x 8")

Pump type	Power [hp]	Ph	Dimensions [inches]											Ship. weight [lbs]	Dimensions [inches]			Ship. weight [lbs]			
			TEFC												ODP				MLE		
			B1	B1+B2	E1	E3	E4	D1	D2	D3	D4	D5	D6		D1	D2	B1+B2		D1	D2	B1+B2
CR(E) 20-1 H	3	1	21.75	36.13	3.00	24.25	28.75	8.63	6.88	4.50	0.75	4.50	3.75	—	—	—	—	—	—	—	—
		3	21.75	35.00	3.00	24.25	28.75	7.13	4.38	4.50	0.75	4.50	3.75	—	—	—	—	7.13	6.63	35.13	—
CR(E) 20-2 H	5	1	21.75	37.00	3.00	24.25	28.75	10.63	7.50	4.50	0.75	4.50	3.75	—	—	—	—	—	—	—	—
		3	21.75	37.25	3.00	24.25	28.75	8.75	5.38	4.50	0.75	4.50	3.75	—	—	—	—	8.75	7.50	37.25	—
CR(E) 20-3 H	7.5	1	24.00	39.25	3.00	27.25	32.75	10.25	7.63	5.25	0.00	5.50	4.25	—	—	—	—	—	—	—	—
		3	24.00	39.50	3.00	27.25	32.75	8.75	5.38	5.25	0.00	5.50	4.25	—	—	—	—	8.75	7.50	39.50	—
CR(E) 20-4 H	10	1	25.75	41.63	3.00	29.00	34.50	11.50	10.38	5.25	0.00	5.50	4.25	—	—	—	—	—	—	—	—
		3	25.75	41.25	3.00	29.00	34.50	8.75	5.38	5.25	0.00	5.50	4.25	—	—	—	—	8.75	7.50	41.25	—
CR 20-5 H	15	3	28.25	46.13	3.00	32.25	40.50	10.25	8.75	6.25	-1.00	8.25	5.00	10.63	6.88	44.38	—	—	—	—	—
CR 20-6 H	15	3	30.00	47.88	3.00	34.00	42.25	10.25	8.75	6.25	-1.00	8.25	5.00	10.63	6.88	46.13	—	—	—	—	—
CR 20-7 H	20	3	31.88	49.38	3.00	35.88	44.13	10.25	8.88	6.25	-1.00	8.25	5.00	11.50	9.13	51.25	—	—	—	—	—
CR 20-8 H	20	3	33.63	51.13	3.00	37.63	45.88	10.25	8.88	6.25	-1.00	8.25	5.00	11.50	9.13	53.00	—	—	—	—	—
CR 20-10 H	25	3	36.38	58.00	3.00	40.88	50.38	13.38	12.13	7.00	-1.75	9.50	5.50	11.50	9.13	56.88	—	—	—	—	—

Note: Terminal box is on top of motor on 3-phase up to 10 hp. All other motors have terminal box on the side. Reference D2 dimension. Weights are based on pump with TEFC motor.

CR, CRE 32 H G22

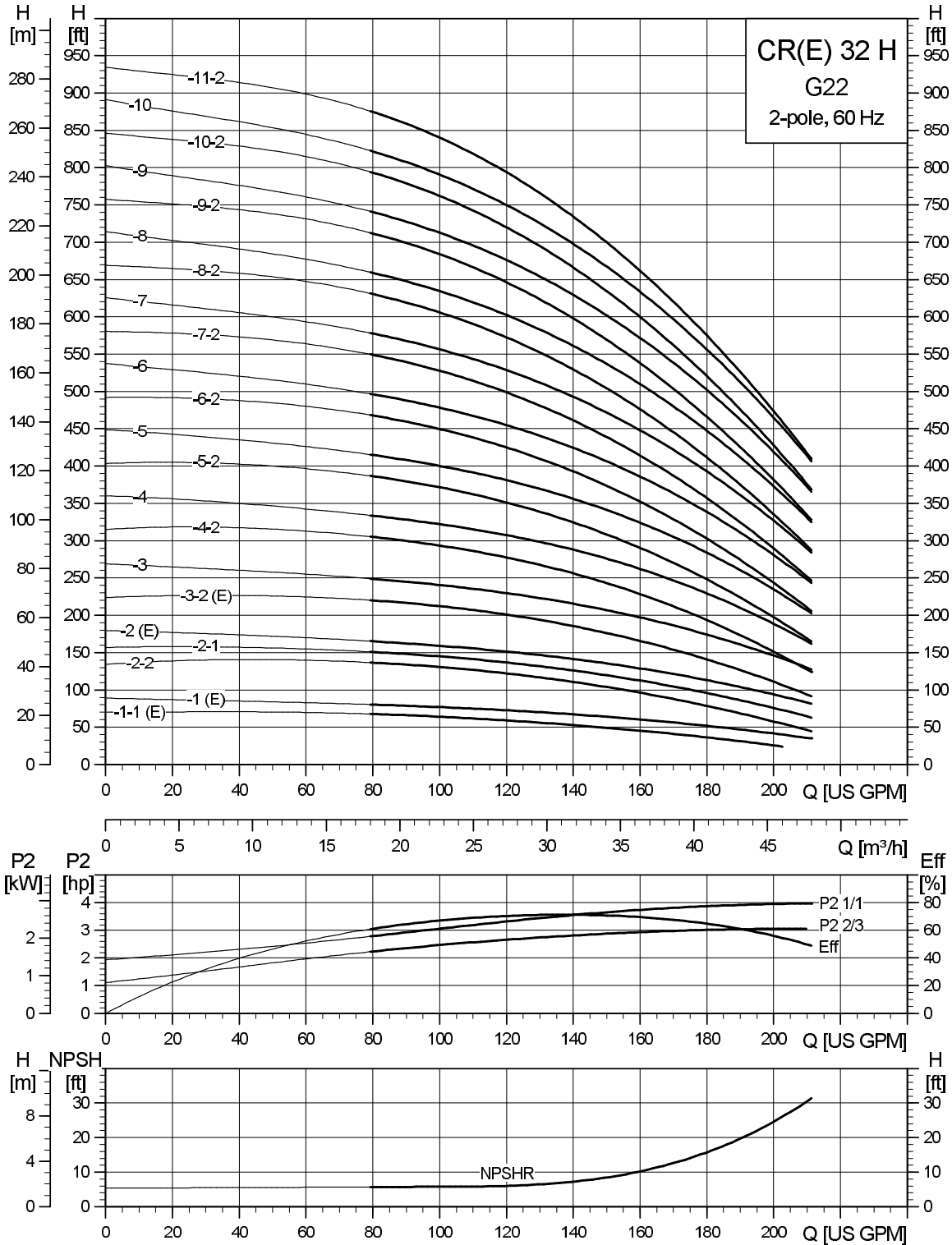

TM04 6295 1110

Dimensional sketches G22 (2" x 2")

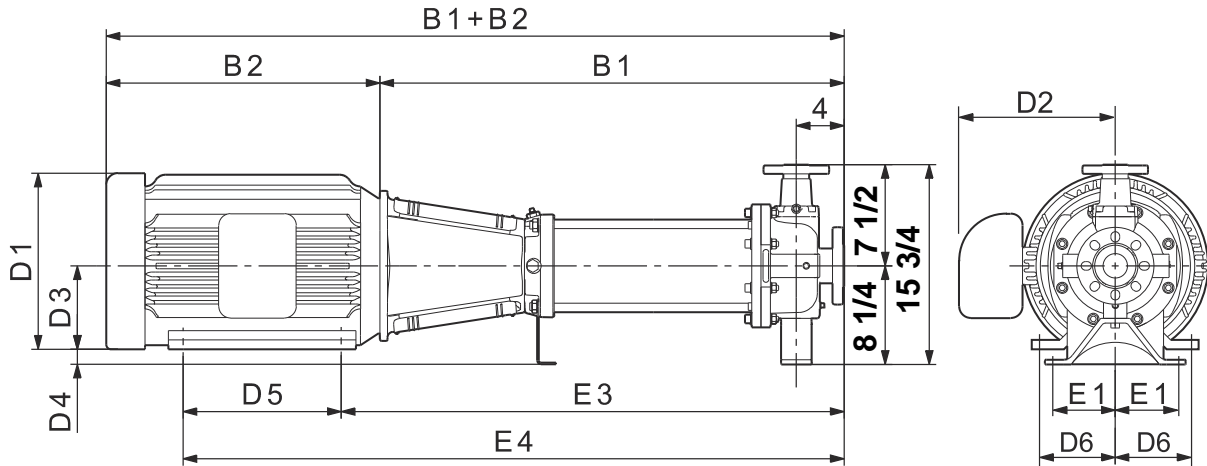

TM04 4872 1010

Dimensions and weights G22 (2" x 2")

Pump type	Power [hp]	Ph	Dimensions [inches]										Ship. weight [lbs]	Dimensions [inches]			Ship. weight [lbs]				
			TEFC											ODP				MLE			
			B1	B1+B2	E1	E3	E4	D1	D2	D3	D4	D5		D6	D1	D2		B1+B2	D1	D2	B1+B2
CR(E) 32-1-1 H	3	1	25.25	39.63	4.88	27.75	32.25	8.63	6.88	4.50	3.75	4.50	3.75	—	—	—	—	—	—	—	—
		3	25.25	38.50	4.88	27.75	32.25	7.13	4.38	4.50	3.75	4.50	3.75	—	—	—	—	7.13	6.63	38.50	—
CR(E) 32-1 H	5	1	25.25	40.50	4.88	27.75	32.25	10.63	7.50	4.50	3.75	4.50	3.75	—	—	—	—	—	—	—	—
		3	25.25	40.75	4.88	27.75	32.25	8.75	5.38	4.50	3.75	4.50	3.75	—	—	—	—	8.75	7.50	40.75	—
CR 32-2-2 H	7.5	1	28.00	43.25	4.88	31.25	36.75	10.25	7.63	5.25	3.00	5.50	4.25	—	—	—	—	5.63	5.63	37.13	—
		3	28.00	43.50	4.88	31.25	36.75	8.75	5.38	5.25	3.00	5.50	4.25	—	—	—	—	—	—	—	—
CR 32-2-1 H	7.5	1	28.00	43.25	4.88	31.25	36.75	10.25	7.63	5.25	3.00	5.50	4.25	—	—	—	—	—	—	—	—
		3	28.00	43.50	4.88	31.25	36.75	8.75	5.38	5.25	3.00	5.50	4.25	—	—	—	—	—	—	—	—
CR(E) 32-2 H	7.5	1	28.00	43.25	4.88	31.25	36.75	10.25	7.63	5.25	3.00	5.50	4.25	—	—	—	—	—	—	—	—
		3	28.00	43.50	4.88	31.25	36.75	8.75	5.38	5.25	3.00	5.50	4.25	—	—	—	—	8.75	7.50	43.50	—
CR(E) 32-3-2 H	10	1	30.75	46.50	4.88	34.00	39.50	11.50	10.38	5.25	3.00	5.50	4.25	—	—	—	—	—	—	—	—
		3	30.75	46.25	4.88	34.00	39.50	8.75	5.38	5.25	3.00	5.50	4.25	—	—	—	—	8.75	7.50	46.25	—
CR 32-3 H	15	3	30.75	48.63	4.88	34.75	43.00	10.25	8.75	6.25	2.00	8.25	5.00	10.63	6.88	46.75	—	—	—	—	—
CR 32-4-2 H	15	3	33.50	51.38	4.88	37.50	45.75	10.25	8.75	6.25	2.00	8.25	5.00	10.63	6.88	49.50	—	—	—	—	—
CR 32-4 H	15	3	33.50	51.38	4.88	37.50	45.75	10.25	8.75	6.25	2.00	8.25	5.00	10.63	6.88	49.50	—	—	—	—	—
CR 32-5-2 H	20	3	36.25	53.88	4.88	40.25	48.50	10.25	8.88	6.25	2.00	8.25	5.00	11.50	9.13	55.75	—	—	—	—	—
CR 32-5 H	20	3	36.25	53.88	4.88	40.25	48.50	10.25	8.88	6.25	2.00	8.25	5.00	11.50	9.13	55.75	—	—	—	—	—
CR 32-6-2 H	25	3	39.00	60.75	4.88	43.50	53.00	13.38	12.13	7.00	1.25	9.50	5.50	11.50	9.13	59.63	—	—	—	—	—
CR 32-6 H	25	3	39.00	60.75	4.88	43.50	53.00	13.38	12.13	7.00	1.25	9.50	5.50	11.50	9.13	59.63	—	—	—	—	—
CR 32-7-2 H	25	3	41.75	63.50	4.88	46.25	55.75	13.38	12.13	7.00	1.25	9.50	5.50	11.50	9.13	62.38	—	—	—	—	—
CR 32-7 H	30	3	41.75	64.75	4.88	46.25	57.25	15.38	13.13	7.00	1.25	11.00	5.50	11.50	9.13	63.38	—	—	—	—	—
CR 32-8-2 H	30	3	44.50	67.50	4.88	49.00	60.00	15.38	13.13	7.00	1.25	11.00	5.50	11.50	9.13	66.13	—	—	—	—	—
CR 32-8 H	30	3	44.50	67.50	4.88	49.00	60.00	15.38	13.13	7.00	1.25	11.00	5.50	11.50	9.13	66.13	—	—	—	—	—
CR 32-9-2 H	40	3	47.25	70.25	4.88	51.75	62.75	15.38	10.50	7.00	1.25	11.00	5.50	13.25	10.00	70.25	—	—	—	—	—
CR 32-9 H	40	3	47.25	70.25	4.88	51.75	62.75	15.38	10.50	7.00	1.25	11.00	5.50	13.25	10.00	70.25	—	—	—	—	—
CR 32-10-2 H	40	3	50.00	73.00	4.88	54.50	65.50	15.38	10.50	7.00	1.25	11.00	5.50	13.25	10.00	73.00	—	—	—	—	—
CR 32-10 H	40	3	50.00	73.00	4.88	54.50	65.50	15.38	10.50	7.00	1.25	11.00	5.50	13.25	10.00	73.00	—	—	—	—	—
CR 32-11-2 H	40	3	52.75	75.75	4.88	57.25	68.25	15.38	10.50	7.00	1.25	11.00	5.50	13.25	10.00	75.75	—	—	—	—	—

Note: Terminal box is on top of motor on 3-phase up to 10 hp. All other motors have terminal box on the side. Reference D2 dimension. Weights are based on pump with TEFC motor.

CR, CRE 32 H GA/G05

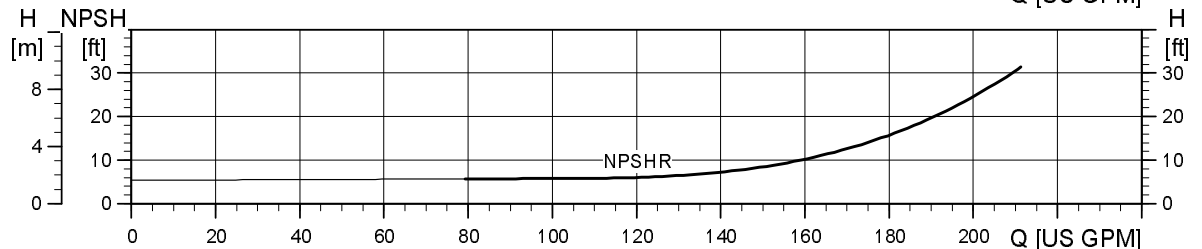
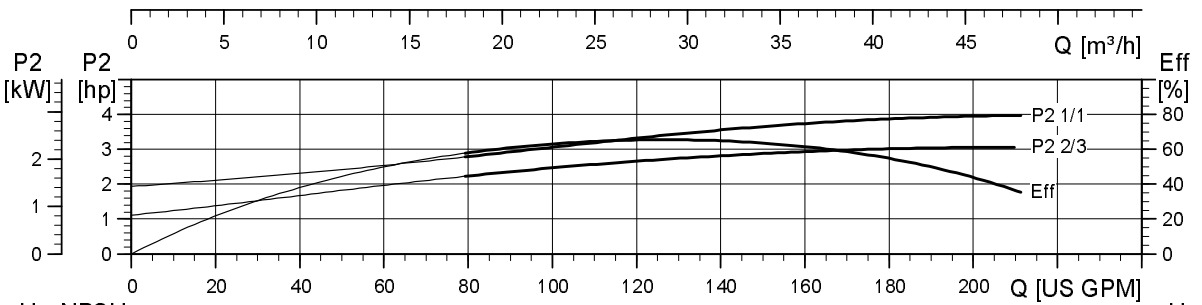
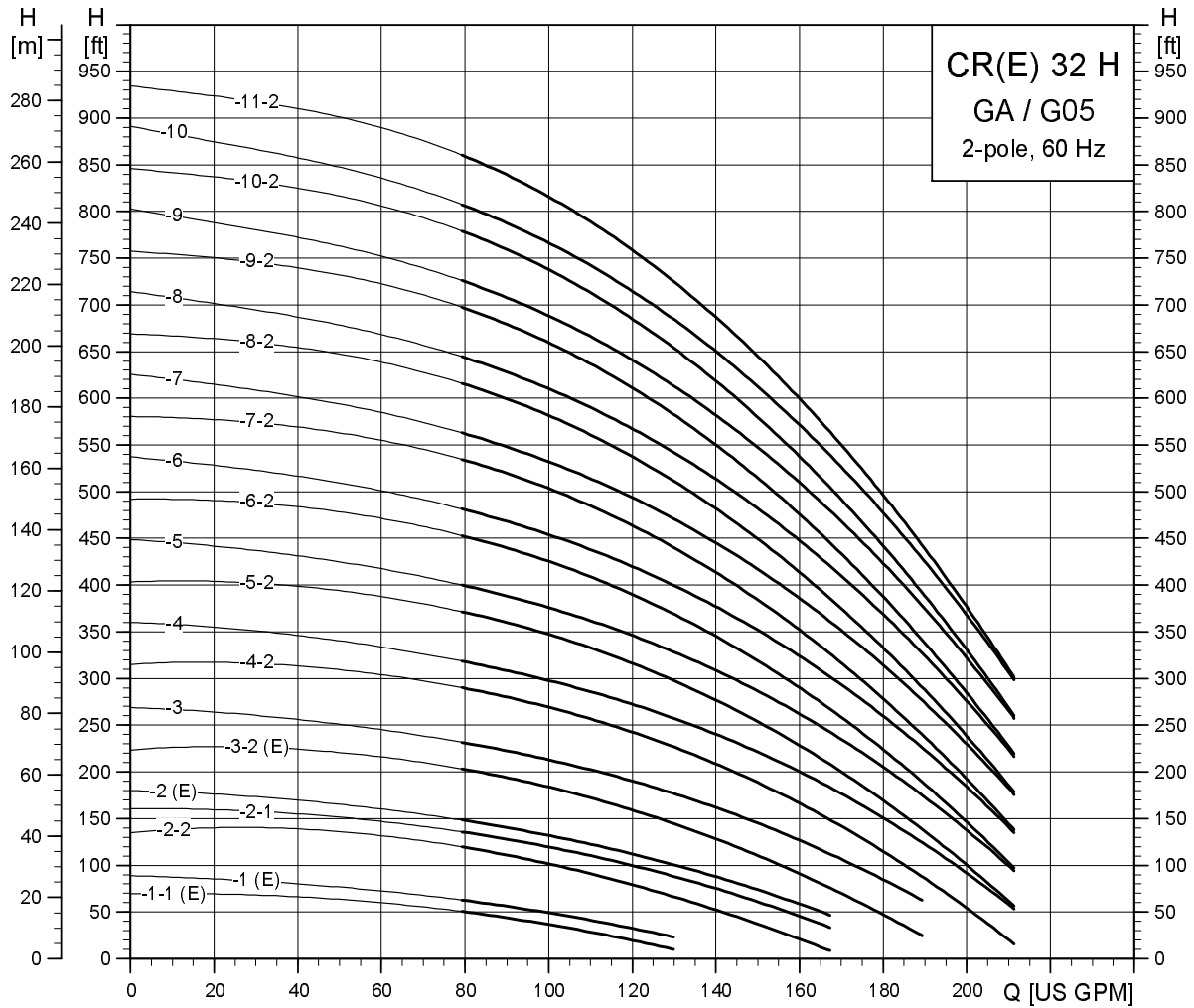

TM04 6292 0310

Dimensional sketches GA (1.5" x 1" x 6", 1.5" x 1" x 8")

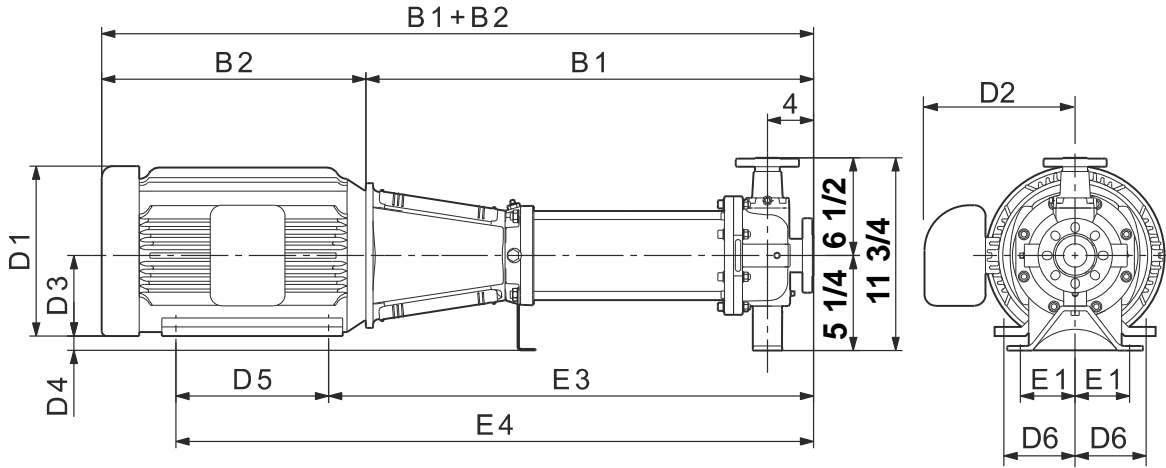

TM04 4819 1010

Dimensions and weights GA (1.5" x 1" x 6", 1.5" x 1" x 8")

Pump type	Power [hp]	Ph	Dimensions [inches]													Ship. weight [lbs]	Dimensions [inches]			Ship. weight [lbs]				
			TEFC										ODP				MLE							
			B1	B1+B	E1	E3	E4	D1	D2	D3	D4	D5	D6	D1	D2		B1+B	D1	D2		B1+B			
CR(E) 32-1-1 H	3	1	25.25	39.63	3.00	27.75	32.25	8.63	6.88	4.50	0.75	4.50	3.75	—	—	—	—	—	—	—	—	—	—	—
		3	25.25	38.50	3.00	27.75	32.25	7.13	4.38	4.50	0.75	4.50	3.75	—	—	—	—	7.13	6.63	38.50	—	—	—	—
CR(E) 32-1 H	5	1	25.25	40.50	3.00	27.75	32.25	10.63	7.50	4.50	0.75	4.50	3.75	—	—	—	—	—	—	—	—	—	—	—
		3	25.25	40.75	3.00	27.75	32.25	8.75	5.38	4.50	0.75	4.50	3.75	—	—	—	—	8.75	7.50	40.75	—	—	—	—
CR 32-2-2 H	7.5	1	28.00	43.25	3.00	31.25	36.75	10.25	7.63	5.25	0.00	5.50	4.25	—	—	—	—	—	—	—	—	—	—	—
		3	28.00	43.50	3.00	31.25	36.75	8.75	5.38	5.25	0.00	5.50	4.25	—	—	—	—	—	—	—	—	—	—	—
CR 32-2-1 H	7.5	1	28.00	43.25	3.00	31.25	36.75	10.25	7.63	5.25	0.00	5.50	4.25	—	—	—	—	—	—	—	—	—	—	—
		3	28.00	43.50	3.00	31.25	36.75	8.75	5.38	5.25	0.00	5.50	4.25	—	—	—	—	—	—	—	—	—	—	—
CR(E) 32-2 H	7.5	1	28.00	43.25	3.00	31.25	36.75	10.25	7.63	5.25	0.00	5.50	4.25	—	—	—	—	—	—	—	—	—	—	—
		3	28.00	43.50	3.00	31.25	36.75	8.75	5.38	5.25	0.00	5.50	4.25	—	—	—	—	8.75	7.50	43.50	—	—	—	—
CR(E) 32-3-2 H	10	1	30.75	46.50	3.00	34.00	39.50	11.50	10.38	5.25	0.00	5.50	4.25	—	—	—	—	—	—	—	—	—	—	—
		3	30.75	46.25	3.00	34.00	39.50	8.75	5.38	5.25	0.00	5.50	4.25	—	—	—	—	8.75	7.50	46.25	—	—	—	—
CR 32-3 H	15	3	30.75	48.63	3.00	34.75	43.00	10.25	8.75	6.25	-1.00	8.25	5.00	10.63	6.88	46.75	—	—	—	—	—	—	—	—
CR 32-4-2 H	15	3	33.50	51.38	3.00	37.50	45.75	10.25	8.75	6.25	-1.00	8.25	5.00	10.63	6.88	49.50	—	—	—	—	—	—	—	—
CR 32-4 H	15	3	33.50	51.38	3.00	37.50	45.75	10.25	8.75	6.25	-1.00	8.25	5.00	10.63	6.88	49.50	—	—	—	—	—	—	—	—
CR 32-5-2 H	20	3	36.25	53.88	3.00	40.25	48.50	10.25	8.88	6.25	-1.00	8.25	5.00	11.50	9.13	55.75	—	—	—	—	—	—	—	—
CR 32-5 H	20	3	36.25	53.88	3.00	40.25	48.50	10.25	8.88	6.25	-1.00	8.25	5.00	11.50	9.13	55.75	—	—	—	—	—	—	—	—
CR 32-6-2 H	25	3	39.00	60.75	3.00	43.50	53.00	13.38	12.13	7.00	-1.75	9.50	5.50	11.50	9.13	59.63	—	—	—	—	—	—	—	—
CR 32-6 H	25	3	39.00	60.75	3.00	43.50	53.00	13.38	12.13	7.00	-1.75	9.50	5.50	11.50	9.13	59.63	—	—	—	—	—	—	—	—
CR 32-7-2 H	25	3	41.75	63.50	3.00	46.25	55.75	13.38	12.13	7.00	-1.75	9.50	5.50	11.50	9.13	62.38	—	—	—	—	—	—	—	—
CR 32-7 H	30	3	41.75	64.75	3.00	46.25	57.25	15.38	13.13	7.00	-1.75	11.00	5.50	11.50	9.13	63.38	—	—	—	—	—	—	—	—
CR 32-8-2 H	30	3	44.50	67.50	3.00	49.00	60.00	15.38	13.13	7.00	-1.75	11.00	5.50	11.50	9.13	66.13	—	—	—	—	—	—	—	—
CR 32-8 H	30	3	44.50	67.50	3.00	49.00	60.00	15.38	13.13	7.00	-1.75	11.00	5.50	11.50	9.13	66.13	—	—	—	—	—	—	—	—
CR 32-9-2 H	40	3	47.25	70.25	3.00	51.75	62.75	15.38	10.50	7.00	-1.75	11.00	5.50	13.25	10.00	70.25	—	—	—	—	—	—	—	—
CR 32-9 H	40	3	47.25	70.25	3.00	51.75	62.75	15.38	10.50	7.00	-1.75	11.00	5.50	13.25	10.00	70.25	—	—	—	—	—	—	—	—
CR 32-10-2 H	40	3	50.00	73.00	3.00	54.50	65.50	15.38	10.50	7.00	-1.75	11.00	5.50	13.25	10.00	73.00	—	—	—	—	—	—	—	—
CR 32-10 H	40	3	50.00	73.00	3.00	54.50	65.50	15.38	10.50	7.00	-1.75	11.00	5.50	13.25	10.00	73.00	—	—	—	—	—	—	—	—
CR 32-11-2 H	40	3	52.75	75.75	3.00	57.25	68.25	15.38	10.50	7.00	-1.75	11.00	5.50	13.25	10.00	75.75	—	—	—	—	—	—	—	—

Note: Terminal box is on top of motor on 3-phase up to 10 hp. All other motors have terminal box on the side. Reference D2 dimension. Weights are based on pump with TEFC motor.

Dimensional sketches G05 (2" x 1" x 10")

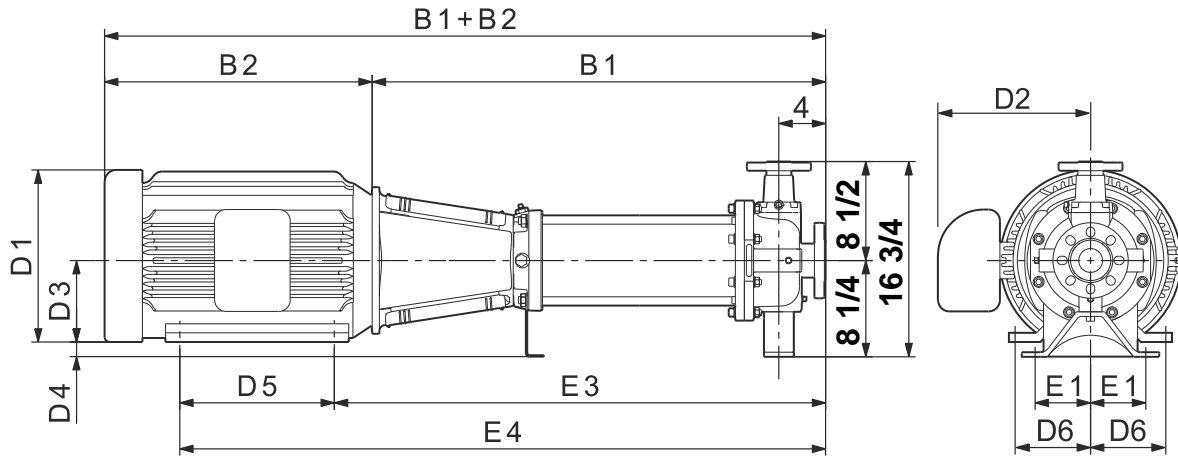

TM04 4644 1010

Dimensions and weights G05 (2" x 1" x 10")

Pump type	Power [hp]	Ph	Dimensions [inches]													Ship. weight [lbs]	Dimensions [inches]			Ship. weight [lbs]			
			TEFC										ODP				MLE						
			B1	B1+B2	E1	E3	E4	D1	D2	D3	D4	D5	D6	D1	D2		B1+B2	D1	D2		B1+B2		
CR(E) 32-1-1 H	3	1	25.25	39.63	4.88	27.75	32.25	8.63	6.88	4.50	3.75	4.50	3.75	—	—	—	—	—	—	—	—	—	—
		3	25.25	38.50	4.88	27.75	32.25	7.13	4.38	4.50	3.75	4.50	3.75	—	—	—	—	7.13	6.63	38.50	—	—	—
CR(E) 32-1 H	5	1	25.25	40.50	4.88	27.75	32.25	10.63	7.50	4.50	3.75	4.50	3.75	—	—	—	—	—	—	—	—	—	—
		3	25.25	40.75	4.88	27.75	32.25	8.75	5.38	4.50	3.75	4.50	3.75	—	—	—	—	8.75	7.50	40.75	—	—	—
CR 32-2-2 H	7.5	1	28.00	43.25	4.88	31.25	36.75	10.25	7.63	5.25	3.00	5.50	4.25	—	—	—	—	—	—	—	—	—	—
		3	28.00	43.50	4.88	31.25	36.75	8.75	5.38	5.25	3.00	5.50	4.25	—	—	—	—	—	—	—	—	—	—
CR 32-2-1 H	7.5	1	28.00	43.25	4.88	31.25	36.75	10.25	7.63	5.25	3.00	5.50	4.25	—	—	—	—	—	—	—	—	—	—
		3	28.00	43.50	4.88	31.25	36.75	8.75	5.38	5.25	3.00	5.50	4.25	—	—	—	—	—	—	—	—	—	—
CR(E) 32-2 H	7.5	1	28.00	43.25	4.88	31.25	36.75	10.25	7.63	5.25	3.00	5.50	4.25	—	—	—	—	—	—	—	—	—	—
		3	28.00	43.50	4.88	31.25	36.75	8.75	5.38	5.25	3.00	5.50	4.25	—	—	—	—	8.75	7.50	43.50	—	—	—
CR(E) 32-3-2 H	10	1	30.75	46.50	4.88	34.00	39.50	11.50	10.38	5.25	3.00	5.50	4.25	—	—	—	—	—	—	—	—	—	—
		3	30.75	46.25	4.88	34.00	39.50	8.75	5.38	5.25	3.00	5.50	4.25	—	—	—	—	8.75	7.50	46.25	—	—	—
CR 32-3 H	15	3	30.75	48.63	4.88	34.75	43.00	10.25	8.75	6.25	2.00	8.25	5.00	10.63	6.88	46.75	—	—	—	—	—	—	—
CR 32-4-2 H	15	3	33.50	51.38	4.88	37.50	45.75	10.25	8.75	6.25	2.00	8.25	5.00	10.63	6.88	49.50	—	—	—	—	—	—	—
CR 32-4 H	15	3	33.50	51.38	4.88	37.50	45.75	10.25	8.75	6.25	2.00	8.25	5.00	10.63	6.88	49.50	—	—	—	—	—	—	—
CR 32-5-2 H	20	3	36.25	53.88	4.88	40.25	48.50	10.25	8.88	6.25	2.00	8.25	5.00	11.50	9.13	55.75	—	—	—	—	—	—	—
CR 32-5 H	20	3	36.25	53.88	4.88	40.25	48.50	10.25	8.88	6.25	2.00	8.25	5.00	11.50	9.13	55.75	—	—	—	—	—	—	—
CR 32-6-2 H	25	3	39.00	60.75	4.88	43.50	53.00	13.38	12.13	7.00	1.25	9.50	5.50	11.50	9.13	59.63	—	—	—	—	—	—	—
CR 32-6 H	25	3	39.00	60.75	4.88	43.50	53.00	13.38	12.13	7.00	1.25	9.50	5.50	11.50	9.13	59.63	—	—	—	—	—	—	—
CR 32-7-2 H	25	3	41.75	63.50	4.88	46.25	55.75	13.38	12.13	7.00	1.25	9.50	5.50	11.50	9.13	62.38	—	—	—	—	—	—	—
CR 32-7 H	30	3	41.75	64.75	4.88	46.25	57.25	15.38	13.13	7.00	1.25	11.00	5.50	11.50	9.13	63.38	—	—	—	—	—	—	—
CR 32-8-2 H	30	3	44.50	67.50	4.88	49.00	60.00	15.38	13.13	7.00	1.25	11.00	5.50	11.50	9.13	66.13	—	—	—	—	—	—	—
CR 32-8 H	30	3	44.50	67.50	4.88	49.00	60.00	15.38	13.13	7.00	1.25	11.00	5.50	11.50	9.13	66.13	—	—	—	—	—	—	—
CR 32-9-2 H	40	3	47.25	70.25	4.88	51.75	62.75	15.38	10.50	7.00	1.25	11.00	5.50	13.25	10.00	70.25	—	—	—	—	—	—	—
CR 32-9 H	40	3	47.25	70.25	4.88	51.75	62.75	15.38	10.50	7.00	1.25	11.00	5.50	13.25	10.00	70.25	—	—	—	—	—	—	—
CR 32-10-2 H	40	3	50.00	73.00	4.88	54.50	65.50	15.38	10.50	7.00	1.25	11.00	5.50	13.25	10.00	73.00	—	—	—	—	—	—	—
CR 32-10 H	40	3	50.00	73.00	4.88	54.50	65.50	15.38	10.50	7.00	1.25	11.00	5.50	13.25	10.00	73.00	—	—	—	—	—	—	—
CR 32-11-2 H	40	3	52.75	75.75	4.88	57.25	68.25	15.38	10.50	7.00	1.25	11.00	5.50	13.25	10.00	75.75	—	—	—	—	—	—	—

Note: Terminal box is on top of motor on 3-phase up to 10 hp. All other motors have terminal box on the side. Reference D2 dimension. Weights are based on pump with TEFC motor.

CR, CRE 32 H GB/G50

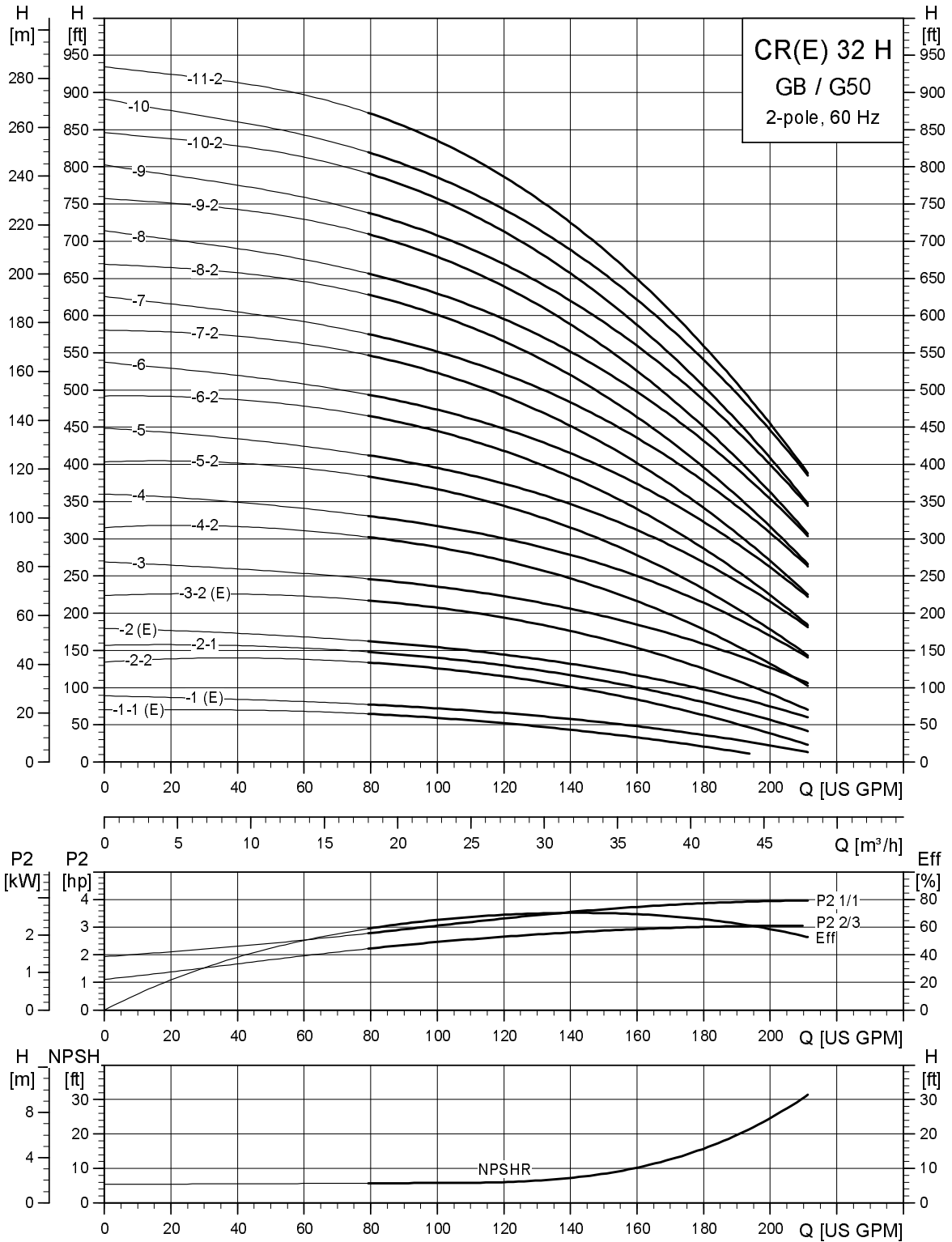

TM04 6293 0310

Dimensional sketches GB (3" x 1.5" x 6", 3" x 1.5" x 8")

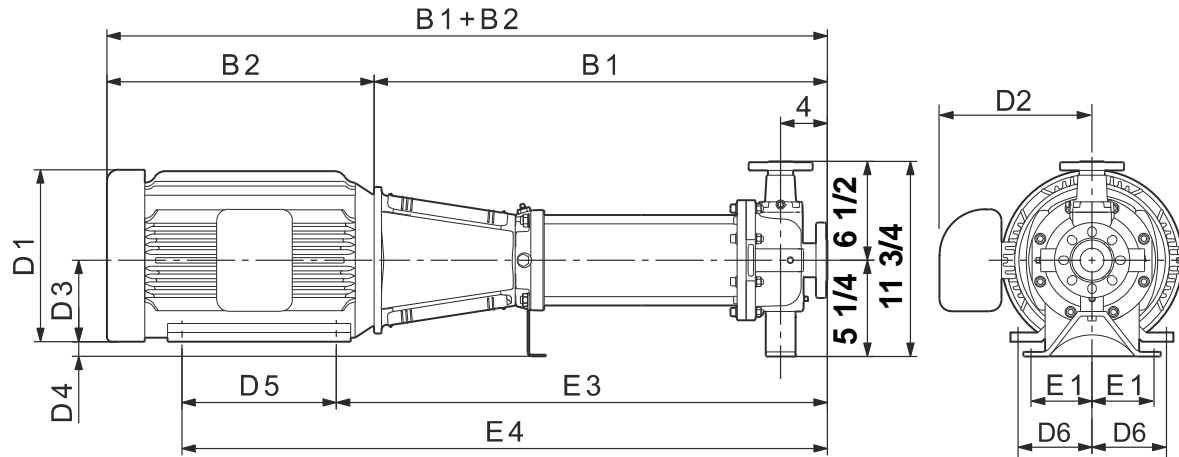

TM04 4872 1010

Dimensions and weights GB (3" x 1.5" x 6", 3" x 1.5" x 8")

Pump type	Power [hp]	Ph	Dimensions [inches]										Ship. weight [lbs]			Dimensions [inches]			Ship. weight [lbs]		
			TEFC										ODP			MLE					
			B1	B1+B2	E1	E3	E4	D1	D2	D3	D4	D5	D6	D1	D2	B1+B2	D1	D2		B1+B2	
CR(E) 32-1-1 H	3	1	26.25	40.63	3.00	28.75	33.25	8.63	6.88	4.50	0.75	4.50	3.75	—	—	—	—	—	—	—	—
		3	26.25	39.50	3.00	28.75	33.25	7.13	4.38	4.50	0.75	4.50	3.75	—	—	—	—	7.13	6.63	39.50	—
CR(E) 32-1 H	5	1	26.25	41.50	3.00	28.75	33.25	10.63	7.50	4.50	0.75	4.50	3.75	—	—	—	—	—	—	—	—
		3	26.25	41.75	3.00	28.75	33.25	8.75	5.38	4.50	0.75	4.50	3.75	—	—	—	—	8.75	7.50	41.75	—
CR 32-2-2 H	7.5	1	29.00	44.25	3.00	32.25	37.75	10.25	7.63	5.25	0.00	5.50	4.25	—	—	—	—	—	—	—	—
		3	29.00	44.50	3.00	32.25	37.75	8.75	5.38	5.25	0.00	5.50	4.25	—	—	—	—	—	—	—	—
CR 32-2-1 H	7.5	1	29.00	44.25	3.00	32.25	37.75	10.25	7.63	5.25	0.00	5.50	4.25	—	—	—	—	—	—	—	—
		3	29.00	44.50	3.00	32.25	37.75	8.75	5.38	5.25	0.00	5.50	4.25	—	—	—	—	—	—	—	—
CR(E) 32-2 H	7.5	1	29.00	44.25	3.00	32.25	37.75	10.25	7.63	5.25	0.00	5.50	4.25	—	—	—	—	—	—	—	—
		3	29.00	44.50	3.00	32.25	37.75	8.75	5.38	5.25	0.00	5.50	4.25	—	—	—	—	8.75	7.50	44.50	—
CR(E) 32-3-2 H	10	1	31.75	47.63	3.00	35.00	40.50	11.50	10.38	5.25	0.00	5.50	4.25	—	—	—	—	—	—	—	—
		3	31.75	47.25	3.00	35.00	40.50	8.75	5.38	5.25	0.00	5.50	4.25	—	—	—	—	8.75	7.50	47.25	—
CR 32-3 H	15	3	31.75	49.63	3.00	35.75	44.00	10.25	8.75	6.25	-1.00	8.25	5.00	10.63	6.88	47.88	—	—	—	—	—
CR 32-4-2 H	15	3	34.50	52.38	3.00	38.50	46.75	10.25	8.75	6.25	-1.00	8.25	5.00	10.63	6.88	50.63	—	—	—	—	—
CR 32-4 H	15	3	34.50	52.38	3.00	38.50	46.75	10.25	8.75	6.25	-1.00	8.25	5.00	10.63	6.88	50.63	—	—	—	—	—
CR 32-5-2 H	20	3	37.25	54.88	3.00	41.25	49.50	10.25	8.88	6.25	-1.00	8.25	5.00	11.50	9.13	56.75	—	—	—	—	—
CR 32-5 H	20	3	37.25	54.88	3.00	41.25	49.50	10.25	8.88	6.25	-1.00	8.25	5.00	11.50	9.13	56.75	—	—	—	—	—
CR 32-6-2 H	25	3	40.00	61.75	3.00	44.50	54.00	13.38	12.13	7.00	-1.75	9.50	5.50	11.50	9.13	60.63	—	—	—	—	—
CR 32-6 H	25	3	40.00	61.75	3.00	44.50	54.00	13.38	12.13	7.00	-1.75	9.50	5.50	11.50	9.13	60.63	—	—	—	—	—
CR 32-7-2 H	25	3	42.75	64.50	3.00	47.25	56.75	13.38	12.13	7.00	-1.75	9.50	5.50	11.50	9.13	63.38	—	—	—	—	—
CR 32-7 H	30	3	42.75	65.75	3.00	47.25	58.25	15.38	13.13	7.00	-1.75	11.00	5.50	11.50	9.13	64.38	—	—	—	—	—
CR 32-8-2 H	30	3	45.50	68.50	3.00	50.00	61.00	15.38	13.13	7.00	-1.75	11.00	5.50	11.50	9.13	67.13	—	—	—	—	—
CR 32-8 H	30	3	45.50	68.50	3.00	50.00	61.00	15.38	13.13	7.00	-1.75	11.00	5.50	11.50	9.13	67.13	—	—	—	—	—
CR 32-9-2 H	40	3	48.25	71.25	3.00	52.75	63.75	15.38	10.50	7.00	-1.75	11.00	5.50	13.25	10.00	71.25	—	—	—	—	—
CR 32-9 H	40	3	48.25	71.25	3.00	52.75	63.75	15.38	10.50	7.00	-1.75	11.00	5.50	13.25	10.00	71.25	—	—	—	—	—
CR 32-10-2 H	40	3	51.00	74.00	3.00	55.50	66.50	15.38	10.50	7.00	-1.75	11.00	5.50	13.25	10.00	74.00	—	—	—	—	—
CR 32-10 H	40	3	51.00	74.00	3.00	55.50	66.50	15.38	10.50	7.00	-1.75	11.00	5.50	13.25	10.00	74.00	—	—	—	—	—
CR 32-11-2 H	40	3	53.75	76.75	3.00	58.25	69.25	15.38	10.50	7.00	-1.75	11.00	5.50	13.25	10.00	76.75	—	—	—	—	—

Note: Terminal box is on top of motor on 3-phase up to 10 hp. All other motors have terminal box on the side. Reference D2 dimension. Weights are based on pump with TEFC motor.

Dimensional sketches G50 (3" x 1.5" x 8, 3" x 1.5" x 10")

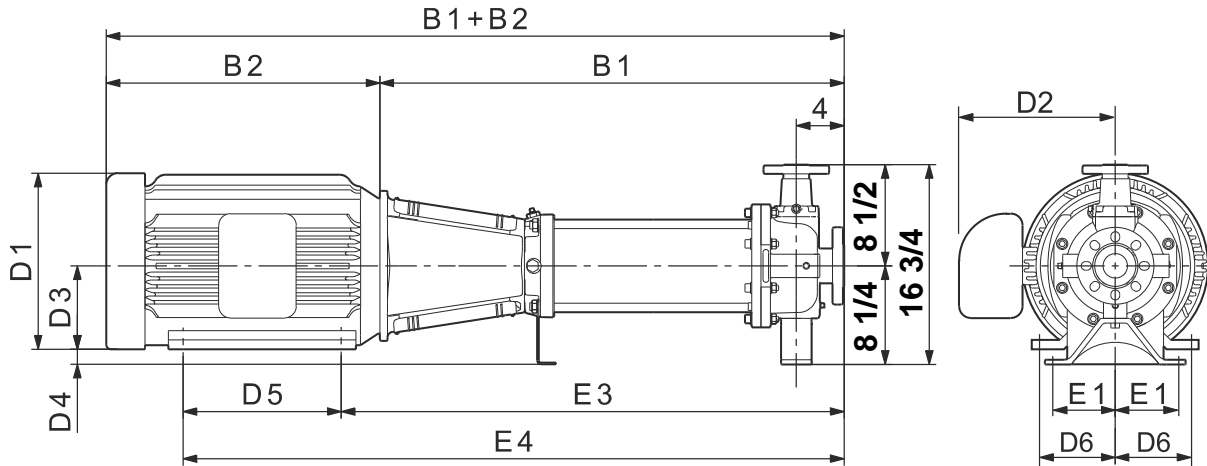

TM04 4872 1010

Dimensions and weights G50 (3" x 1.5" x 8", 3" x 1.5" x 10")

Pump type	Power [hp]	Ph	Dimensions [inches]											Ship. weight [lbs]	Dimensions [inches]			Ship. weight [lbs]			
			TEFC												ODP				MLE		
			B1	B1+B2	E1	E3	E4	D1	D2	D3	D4	D5	D6		D1	D2	B1+B2		D1	D2	B1+B2
CR(E) 32-1-1 H	3	1	26.25	40.63	4.88	28.75	33.25	8.63	6.88	4.50	3.75	4.50	3.75	—	—	—	—	—	—	—	—
		3	26.25	39.50	4.88	28.75	33.25	7.13	4.38	4.50	3.75	4.50	3.75	—	—	—	—	7.13	6.63	39.50	—
CR(E) 32-1 H	5	1	26.25	41.50	4.88	28.75	33.25	10.63	7.50	4.50	3.75	4.50	3.75	—	—	—	—	—	—	—	—
		3	26.25	41.75	4.88	28.75	33.25	8.75	5.38	4.50	3.75	4.50	3.75	—	—	—	—	8.75	7.50	41.75	—
CR 32-2-2 H	7.5	1	29.00	44.25	4.88	32.25	37.75	10.25	7.63	5.25	3.00	5.50	4.25	—	—	—	—	—	—	—	—
		3	29.00	44.50	4.88	32.25	37.75	8.75	5.38	5.25	3.00	5.50	4.25	—	—	—	—	—	—	—	—
CR 32-2-1 H	7.5	1	29.00	44.25	4.88	32.25	37.75	10.25	7.63	5.25	3.00	5.50	4.25	—	—	—	—	—	—	—	—
		3	29.00	44.50	4.88	32.25	37.75	8.75	5.38	5.25	3.00	5.50	4.25	—	—	—	—	—	—	—	—
CR(E) 32-2 H	7.5	1	29.00	44.25	4.88	32.25	37.75	10.25	7.63	5.25	3.00	5.50	4.25	—	—	—	—	—	—	—	—
		3	29.00	44.50	4.88	32.25	37.75	8.75	5.38	5.25	3.00	5.50	4.25	—	—	—	—	8.75	7.50	44.50	—
CR(E) 32-3-2 H	10	1	31.75	47.63	4.88	35.00	40.50	11.50	10.38	5.25	3.00	5.50	4.25	—	—	—	—	—	—	—	—
		3	31.75	47.25	4.88	35.00	40.50	8.75	5.38	5.25	3.00	5.50	4.25	—	—	—	—	8.75	7.50	47.25	—
CR 32-3 H	15	3	31.75	49.63	4.88	35.75	44.00	10.25	8.75	6.25	2.00	8.25	5.00	10.63	6.88	47.88	—	—	—	—	—
CR 32-4-2 H	15	3	34.50	52.38	4.88	38.50	46.75	10.25	8.75	6.25	2.00	8.25	5.00	10.63	6.88	50.63	—	—	—	—	—
CR 32-4 H	15	3	34.50	52.38	4.88	38.50	46.75	10.25	8.75	6.25	2.00	8.25	5.00	10.63	6.88	50.63	—	—	—	—	—
CR 32-5-2 H	20	3	37.25	54.88	4.88	41.25	49.50	10.25	8.88	6.25	2.00	8.25	5.00	11.50	9.13	56.75	—	—	—	—	—
CR 32-5 H	20	3	37.25	54.88	4.88	41.25	49.50	10.25	8.88	6.25	2.00	8.25	5.00	11.50	9.13	56.75	—	—	—	—	—
CR 32-6-2 H	25	3	40.00	61.75	4.88	44.50	54.00	13.38	12.13	7.00	1.25	9.50	5.50	11.50	9.13	60.63	—	—	—	—	—
CR 32-6 H	25	3	40.00	61.75	4.88	44.50	54.00	13.38	12.13	7.00	1.25	9.50	5.50	11.50	9.13	60.63	—	—	—	—	—
CR 32-7-2 H	25	3	42.75	64.50	4.88	47.25	56.75	13.38	12.13	7.00	1.25	9.50	5.50	11.50	9.13	63.38	—	—	—	—	—
CR 32-7 H	30	3	42.75	65.75	4.88	47.25	58.25	15.38	13.13	7.00	1.25	11.00	5.50	11.50	9.13	64.38	—	—	—	—	—
CR 32-8-2 H	30	3	45.50	68.50	4.88	50.00	61.00	15.38	13.13	7.00	1.25	11.00	5.50	11.50	9.13	67.13	—	—	—	—	—
CR 32-8 H	30	3	45.50	68.50	4.88	50.00	61.00	15.38	13.13	7.00	1.25	11.00	5.50	11.50	9.13	67.13	—	—	—	—	—
CR 32-9-2 H	40	3	48.25	71.25	4.88	52.75	63.75	15.38	10.50	7.00	1.25	11.00	5.50	13.25	10.00	71.25	—	—	—	—	—
CR 32-9 H	40	3	48.25	71.25	4.88	52.75	63.75	15.38	10.50	7.00	1.25	11.00	5.50	13.25	10.00	71.25	—	—	—	—	—
CR 32-10-2 H	40	3	51.00	74.00	4.88	55.50	66.50	15.38	10.50	7.00	1.25	11.00	5.50	13.25	10.00	74.00	—	—	—	—	—
CR 32-10 H	40	3	51.00	74.00	4.88	55.50	66.50	15.38	10.50	7.00	1.25	11.00	5.50	13.25	10.00	74.00	—	—	—	—	—
CR 32-11-2 H	40	3	53.75	76.75	4.88	58.25	69.25	15.38	10.50	7.00	1.25	11.00	5.50	13.25	10.00	76.75	—	—	—	—	—

Note: Terminal box is on top of motor on 3-phase up to 10 hp. All other motors have terminal box on the side. Reference D2 dimension. Weights are based on pump with TEFC motor.

CR, CRE 32 H GC/G10/G60

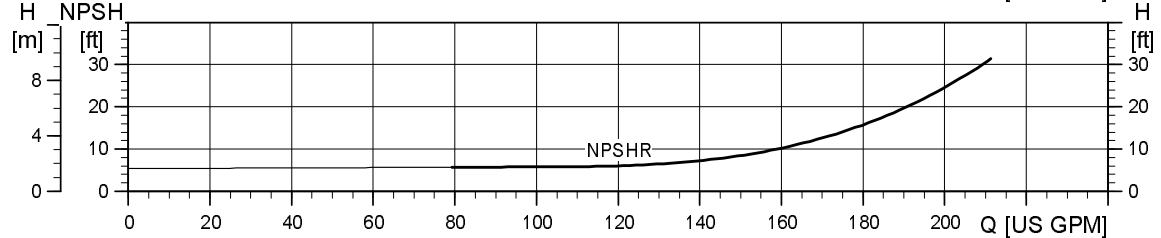
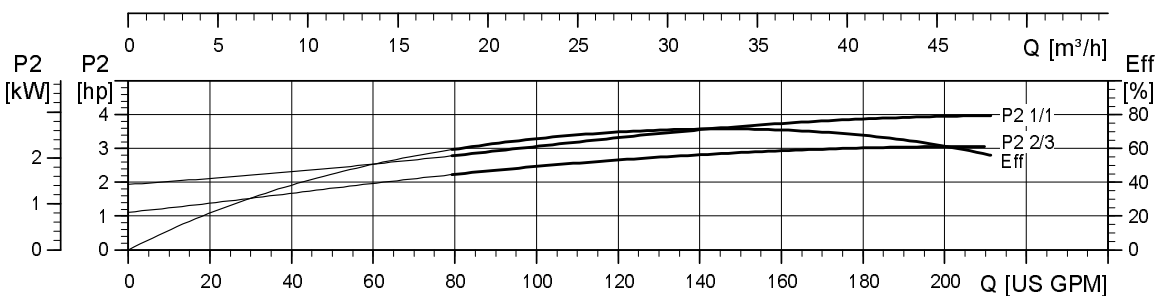
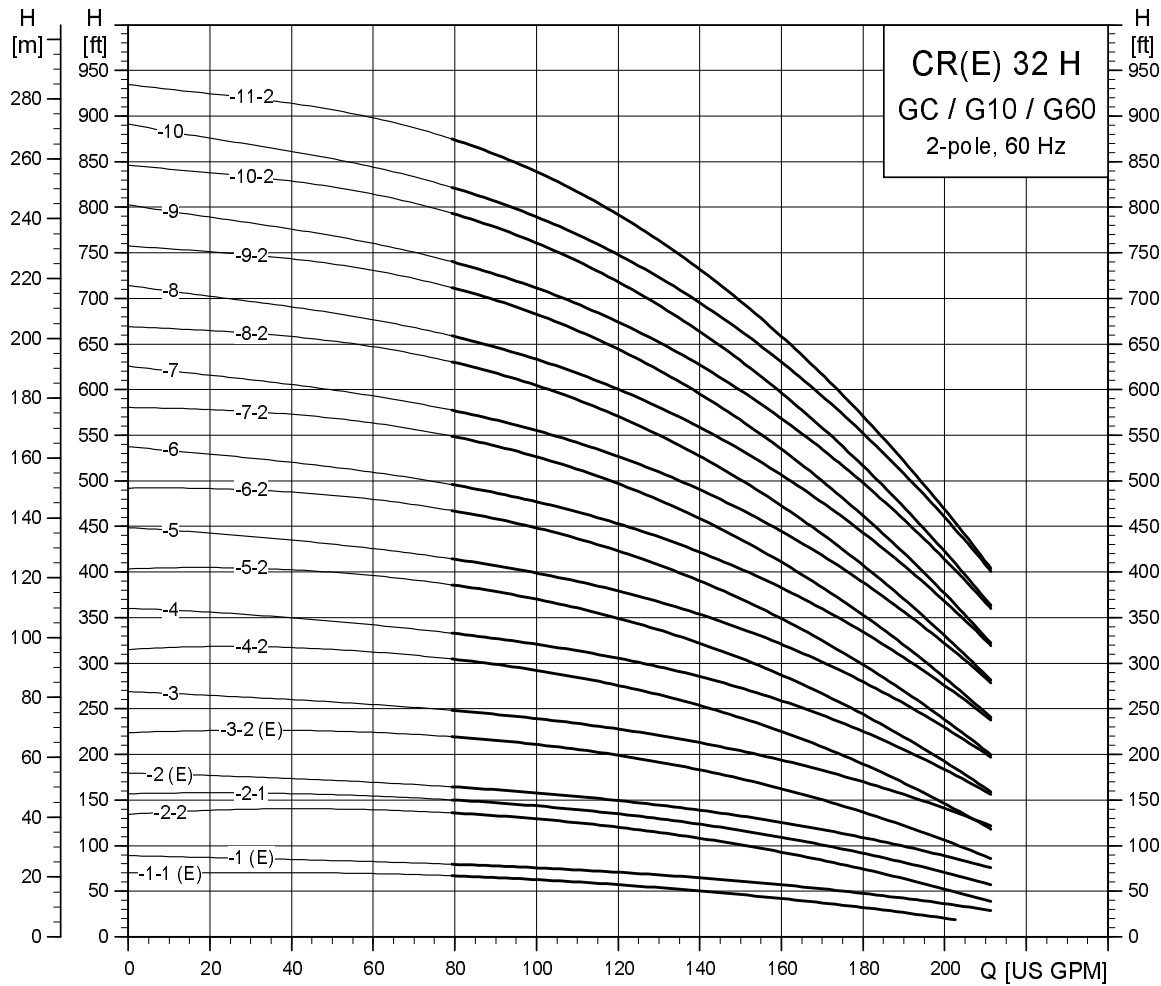

TM04 6294 0310

Dimensional sketches GC (3" x 2" x 6")

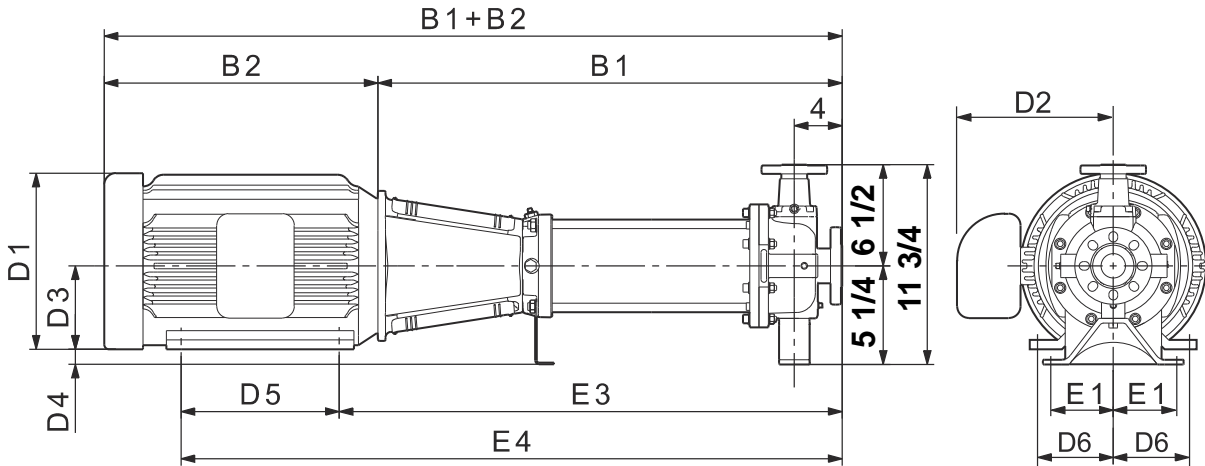

TM04 4872 1010

Dimensions and weights GC (3" x 2" x 6")

Pump type	Power [hp]	Ph	Dimensions [inches]												Ship. weight [lbs]	Dimensions [inches]			Ship. weight [lbs]				
			TEFC													ODP				MLE			
			B1	B1+B2	E1	E3	E4	D1	D2	D3	D4	D5	D6	D1		D2	B1+B2	D1		D2	B1+B2		
CR(E) 32-1-1 H	3	1	26.25	40.63	3.00	28.75	33.25	8.63	6.88	4.50	0.75	4.50	3.75	—	—	—	—	—	—	—	—	—	—
		3	26.25	39.50	3.00	28.75	33.25	7.13	4.38	4.50	0.75	4.50	3.75	—	—	—	—	7.13	6.63	39.50	—	—	—
CR(E) 32-1 H	5	1	26.25	41.50	3.00	28.75	33.25	10.63	7.50	4.50	0.75	4.50	3.75	—	—	—	—	—	—	—	—	—	—
		3	26.25	41.75	3.00	28.75	33.25	8.75	5.38	4.50	0.75	4.50	3.75	—	—	—	—	8.75	7.50	41.75	—	—	—
CR 32-2-2 H	7.5	1	29.00	44.25	3.00	32.25	37.75	10.25	7.63	5.25	0.00	5.50	4.25	—	—	—	—	—	—	—	—	—	—
		3	29.00	44.50	3.00	32.25	37.75	8.75	5.38	5.25	0.00	5.50	4.25	—	—	—	—	—	—	—	—	—	—
CR 32-2-1 H	7.5	1	29.00	44.25	3.00	32.25	37.75	10.25	7.63	5.25	0.00	5.50	4.25	—	—	—	—	—	—	—	—	—	—
		3	29.00	44.50	3.00	32.25	37.75	8.75	5.38	5.25	0.00	5.50	4.25	—	—	—	—	—	—	—	—	—	—
CR(E) 32-2 H	7.5	1	29.00	44.25	3.00	32.25	37.75	10.25	7.63	5.25	0.00	5.50	4.25	—	—	—	—	—	—	—	—	—	—
		3	29.00	44.50	3.00	32.25	37.75	8.75	5.38	5.25	0.00	5.50	4.25	—	—	—	—	8.75	7.50	44.50	—	—	—
CR(E) 32-3-2 H	10	1	31.75	47.63	3.00	35.00	40.50	11.50	10.38	5.25	0.00	5.50	4.25	—	—	—	—	—	—	—	—	—	—
		3	31.75	47.25	3.00	35.00	40.50	8.75	5.38	5.25	0.00	5.50	4.25	—	—	—	—	8.75	7.50	47.25	—	—	—
CR 32-3 H	15	3	31.75	49.63	3.00	35.75	44.00	10.25	8.75	6.25	-1.00	8.25	5.00	10.63	6.88	47.88	—	—	—	—	—	—	—
CR 32-4-2 H	15	3	34.50	52.38	3.00	38.50	46.75	10.25	8.75	6.25	-1.00	8.25	5.00	10.63	6.88	50.63	—	—	—	—	—	—	—
CR 32-4 H	15	3	34.50	52.38	3.00	38.50	46.75	10.25	8.75	6.25	-1.00	8.25	5.00	10.63	6.88	50.63	—	—	—	—	—	—	—
CR 32-5-2 H	20	3	37.25	54.88	3.00	41.25	49.50	10.25	8.88	6.25	-1.00	8.25	5.00	11.50	9.13	56.75	—	—	—	—	—	—	—
CR 32-5 H	20	3	37.25	54.88	3.00	41.25	49.50	10.25	8.88	6.25	-1.00	8.25	5.00	11.50	9.13	56.75	—	—	—	—	—	—	—
CR 32-6-2 H	25	3	40.00	61.75	3.00	44.50	54.00	13.38	12.13	7.00	-1.75	9.50	5.50	11.50	9.13	60.63	—	—	—	—	—	—	—
CR 32-6 H	25	3	40.00	61.75	3.00	44.50	54.00	13.38	12.13	7.00	-1.75	9.50	5.50	11.50	9.13	60.63	—	—	—	—	—	—	—
CR 32-7-2 H	25	3	42.75	64.50	3.00	47.25	56.75	13.38	12.13	7.00	-1.75	9.50	5.50	11.50	9.13	63.38	—	—	—	—	—	—	—
CR 32-7 H	30	3	42.75	65.75	3.00	47.25	58.25	15.38	13.13	7.00	-1.75	11.00	5.50	11.50	9.13	64.38	—	—	—	—	—	—	—
CR 32-8-2 H	30	3	45.50	68.50	3.00	50.00	61.00	15.38	13.13	7.00	-1.75	11.00	5.50	11.50	9.13	67.13	—	—	—	—	—	—	—
CR 32-8 H	30	3	45.50	68.50	3.00	50.00	61.00	15.38	13.13	7.00	-1.75	11.00	5.50	11.50	9.13	67.13	—	—	—	—	—	—	—
CR 32-9-2 H	40	3	48.25	71.25	3.00	52.75	63.75	15.38	10.50	7.00	-1.75	11.00	5.50	13.25	10.00	71.25	—	—	—	—	—	—	—
CR 32-9 H	40	3	48.25	71.25	3.00	52.75	63.75	15.38	10.50	7.00	-1.75	11.00	5.50	13.25	10.00	71.25	—	—	—	—	—	—	—
CR 32-10-2 H	40	3	51.00	74.00	3.00	55.50	66.50	15.38	10.50	7.00	-1.75	11.00	5.50	13.25	10.00	74.00	—	—	—	—	—	—	—
CR 32-10 H	40	3	51.00	74.00	3.00	55.50	66.50	15.38	10.50	7.00	-1.75	11.00	5.50	13.25	10.00	74.00	—	—	—	—	—	—	—
CR 32-11-2 H	40	3	53.75	76.75	3.00	58.25	69.25	15.38	10.50	7.00	-1.75	11.00	5.50	13.25	10.00	76.75	—	—	—	—	—	—	—

Note: Terminal box is on top of motor on 3-phase up to 10 hp. All other motors have terminal box on the side. Reference D2 dimension. Weights are based on pump with TEFC motor.

Dimensional sketches G60 (3" x 2" x 8", 3" x 2" x 10")

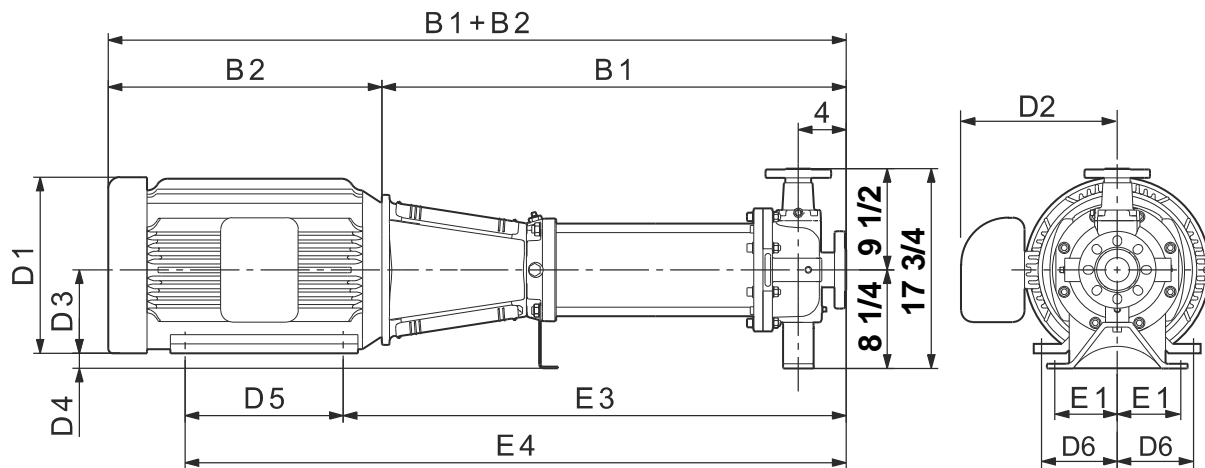

TM04 4872 1010

Dimensions and weights G60 (3" x 2" x 8", 3" x 2" x 10")

Pump type	Power [hp]	Ph	Dimensions [inches]												Ship. weight [lbs]	Dimensions [inches]			Ship. weight [lbs]			
			TEFC													ODP				MLE		
			B1	B1+B2	E1	E3	E4	D1	D2	D3	D4	D5	D6	D1		D2	B1+B2	D1		D2	B1+B2	
CR(E) 32-1-1 H	3	1	26.25	40.63	4.88	28.75	33.25	8.63	6.88	4.50	3.75	4.50	3.75	—	—	—	—	—	—	—	—	
		3	26.25	39.50	4.88	28.75	33.25	7.13	4.38	4.50	3.75	4.50	3.75	—	—	—	—	7.13	6.63	39.50	—	
CR(E) 32-1 H	5	1	26.25	41.50	4.88	28.75	33.25	10.63	7.50	4.50	3.75	4.50	3.75	—	—	—	—	—	—	—	—	
		3	26.25	41.75	4.88	28.75	33.25	8.75	5.38	4.50	3.75	4.50	3.75	—	—	—	—	8.75	7.50	41.75	—	
CR 32-2-2 H	7.5	1	29.00	44.25	4.88	32.25	37.75	10.25	7.63	5.25	3.00	5.50	4.25	—	—	—	—	—	—	—	—	
		3	29.00	44.50	4.88	32.25	37.75	8.75	5.38	5.25	3.00	5.50	4.25	—	—	—	—	—	—	—	—	
CR 32-2-1 H	7.5	1	29.00	44.25	4.88	32.25	37.75	10.25	7.63	5.25	3.00	5.50	4.25	—	—	—	—	—	—	—	—	
		3	29.00	44.50	4.88	32.25	37.75	8.75	5.38	5.25	3.00	5.50	4.25	—	—	—	—	—	—	—	—	
CR(E) 32-2 H	7.5	1	29.00	44.25	4.88	32.25	37.75	10.25	7.63	5.25	3.00	5.50	4.25	—	—	—	—	—	—	—	—	
		3	29.00	44.50	4.88	32.25	37.75	8.75	5.38	5.25	3.00	5.50	4.25	—	—	—	—	8.75	7.50	44.50	—	
CR(E) 32-3-2 H	10	1	31.75	47.63	4.88	35.00	40.50	11.50	10.38	5.25	3.00	5.50	4.25	—	—	—	—	—	—	—	—	
		3	31.75	47.25	4.88	35.00	40.50	8.75	5.38	5.25	3.00	5.50	4.25	—	—	—	—	8.75	7.50	47.25	—	
CR 32-3 H	15	3	31.75	49.63	4.88	35.75	44.00	10.25	8.75	6.25	2.00	8.25	5.00	10.63	6.88	47.88	—	—	—	—	—	
CR 32-4-2 H	15	3	34.50	52.38	4.88	38.50	46.75	10.25	8.75	6.25	2.00	8.25	5.00	10.63	6.88	50.63	—	—	—	—	—	
CR 32-4 H	15	3	34.50	52.38	4.88	38.50	46.75	10.25	8.75	6.25	2.00	8.25	5.00	10.63	6.88	50.63	—	—	—	—	—	
CR 32-5-2 H	20	3	37.25	54.88	4.88	41.25	49.50	10.25	8.88	6.25	2.00	8.25	5.00	11.50	9.13	56.75	—	—	—	—	—	
CR 32-5 H	20	3	37.25	54.88	4.88	41.25	49.50	10.25	8.88	6.25	2.00	8.25	5.00	11.50	9.13	56.75	—	—	—	—	—	
CR 32-6-2 H	25	3	40.00	61.75	4.88	44.50	54.00	13.38	12.13	7.00	1.25	9.50	5.50	11.50	9.13	60.63	—	—	—	—	—	
CR 32-6 H	25	3	40.00	61.75	4.88	44.50	54.00	13.38	12.13	7.00	1.25	9.50	5.50	11.50	9.13	60.63	—	—	—	—	—	
CR 32-7-2 H	25	3	42.75	64.50	4.88	47.25	56.75	13.38	12.13	7.00	1.25	9.50	5.50	11.50	9.13	63.38	—	—	—	—	—	
CR 32-7 H	30	3	42.75	65.75	4.88	47.25	58.25	15.38	13.13	7.00	1.25	11.00	5.50	11.50	9.13	64.38	—	—	—	—	—	
CR 32-8-2 H	30	3	45.50	68.50	4.88	50.00	61.00	15.38	13.13	7.00	1.25	11.00	5.50	11.50	9.13	67.13	—	—	—	—	—	
CR 32-8 H	30	3	45.50	68.50	4.88	50.00	61.00	15.38	13.13	7.00	1.25	11.00	5.50	11.50	9.13	67.13	—	—	—	—	—	
CR 32-9-2 H	40	3	48.25	71.25	4.88	52.75	63.75	15.38	10.50	7.00	1.25	11.00	5.50	13.25	10.00	71.25	—	—	—	—	—	
CR 32-9 H	40	3	48.25	71.25	4.88	52.75	63.75	15.38	10.50	7.00	1.25	11.00	5.50	13.25	10.00	71.25	—	—	—	—	—	
CR 32-10-2 H	40	3	51.00	74.00	4.88	55.50	66.50	15.38	10.50	7.00	1.25	11.00	5.50	13.25	10.00	74.00	—	—	—	—	—	
CR 32-10 H	40	3	51.00	74.00	4.88	55.50	66.50	15.38	10.50	7.00	1.25	11.00	5.50	13.25	10.00	74.00	—	—	—	—	—	
CR 32-11-2 H	40	3	53.75	76.75	4.88	58.25	69.25	15.38	10.50	7.00	1.25	11.00	5.50	13.25	10.00	76.75	—	—	—	—	—	

Note: Terminal box is on top of motor on 3-phase up to 10 hp. All other motors have terminal box on the side. Reference D2 dimension. Weights are based on pump with TEFC motor.

CR, CRE 45 H G33

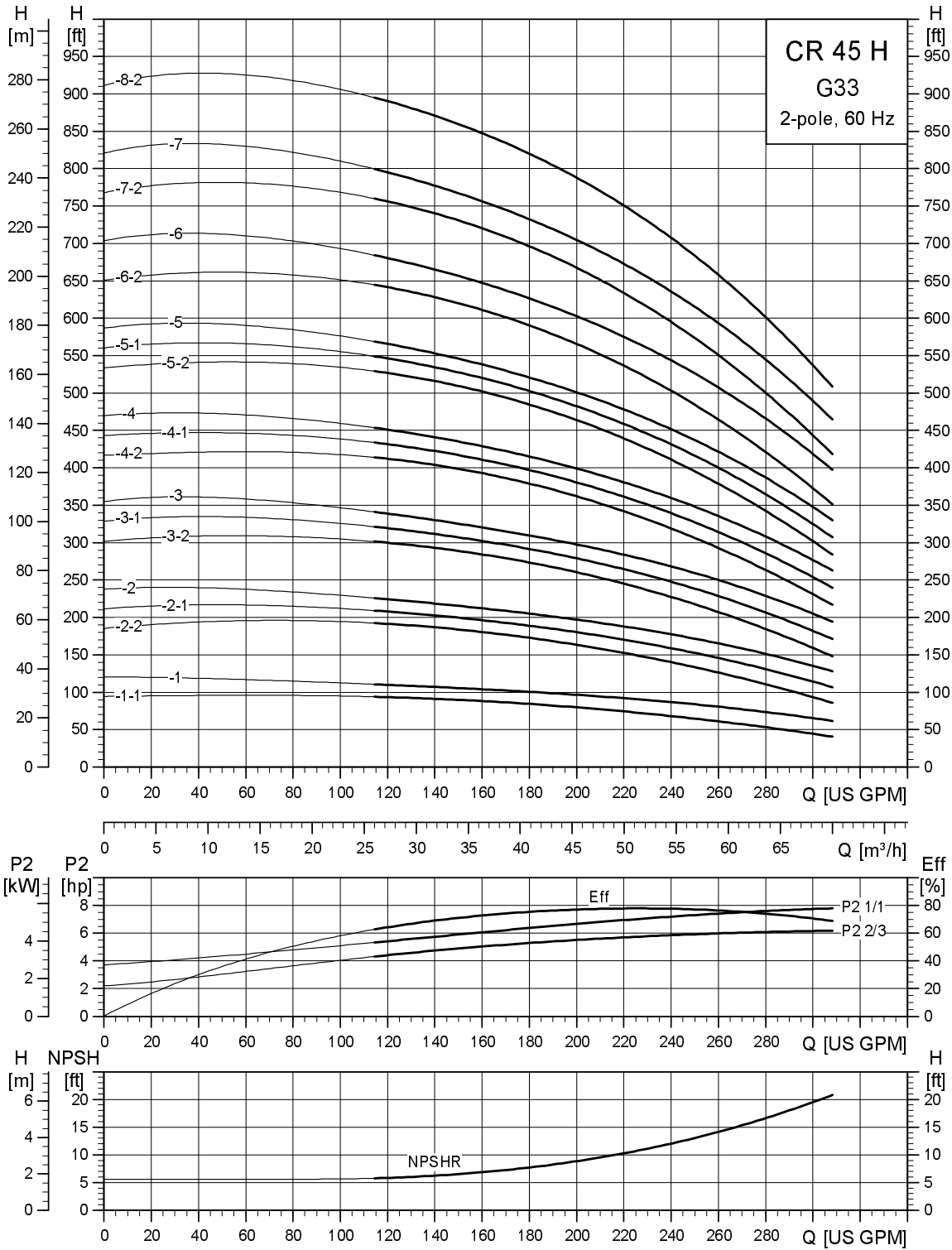

TM04 6298 0310

Dimensional sketches G33 (3" x 3")

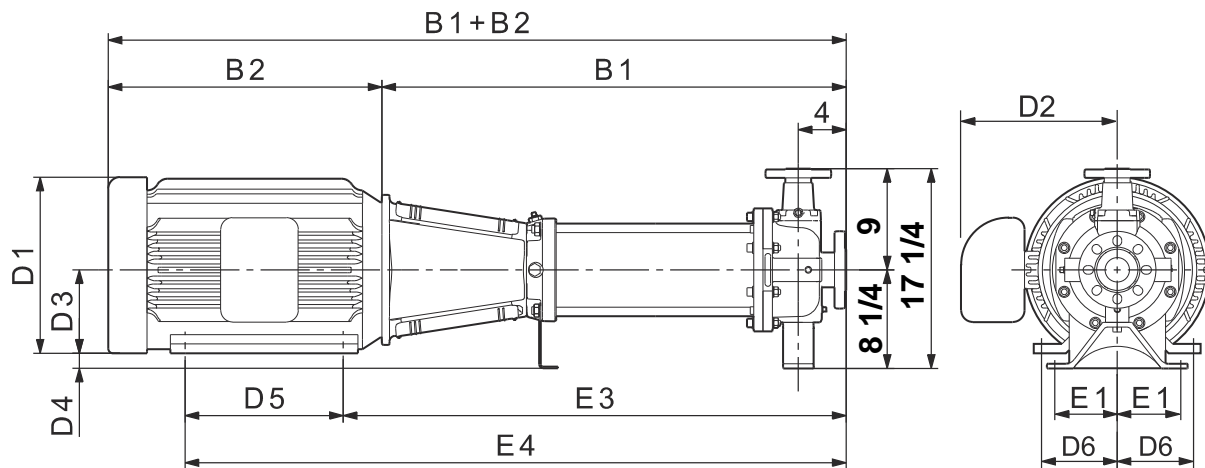

TM04 4872 0310

Dimensions and weights G33 (3" x 3")

Pump type	Power [hp]	Ph	Dimensions [inches]												Ship. weight [lbs]	Dimensions [inches]			Ship. weight [lbs]				
			TEFC										ODP			MLE							
			B1	B1+B2	E1	E3	E4	D1	D2	D3	D4	D5	D6	D1		D2	B1+B2	D1		D2	B1+B2		
CR(E) 45-1-1 H	7.5	1	25.88	41.13	4.88	29.13	34.63	10.25	7.63	5.25	3.00	5.50	4.25	—	—	—	—	—	—	—	—	—	—
		3	25.88	41.38	4.88	29.13	34.63	8.75	5.38	5.25	3.00	5.50	4.25	—	—	—	—	8.75	7.50	41.38	—	—	—
CR(E) 45-1 H	7.5	1	25.88	41.13	4.88	29.13	34.63	10.25	7.63	5.25	3.00	5.50	4.25	—	—	—	—	—	—	—	—	—	—
		3	25.88	41.38	4.88	29.13	34.63	8.75	5.38	5.25	3.00	5.50	4.25	—	—	—	—	8.75	7.50	41.38	—	—	—
CR 45-2-2 H	15	3	29.00	46.88	4.88	33.00	41.25	10.25	8.75	6.25	2.00	8.25	5.00	10.63	6.88	45.13	—	—	—	—	—	—	—
CR 45-2-1 H	15	3	29.00	46.88	4.88	33.00	41.25	10.25	8.75	6.25	2.00	8.25	5.00	10.63	6.88	45.13	—	—	—	—	—	—	—
CR 45-2 H	15	3	29.00	46.88	4.88	33.00	41.25	10.25	8.75	6.25	2.00	8.25	5.00	10.63	6.88	45.13	—	—	—	—	—	—	—
CR 45-3-2 H	20	3	32.13	49.75	4.88	36.13	44.38	10.25	8.88	6.25	2.00	8.25	5.00	11.50	9.13	51.63	—	—	—	—	—	—	—
CR 45-3-1 H	25	3	32.13	53.88	4.88	36.63	46.13	13.38	12.13	7.00	1.25	9.50	5.50	11.50	9.13	52.75	—	—	—	—	—	—	—
CR 45-3 H	25	3	32.13	53.88	4.88	36.63	46.13	13.38	12.13	7.00	1.25	9.50	5.50	11.50	9.13	52.75	—	—	—	—	—	—	—
CR 45-4-2 H	30	3	35.25	58.25	4.88	39.75	50.75	15.38	13.13	7.00	1.25	11.00	5.50	11.50	9.13	56.88	—	—	—	—	—	—	—
CR 45-4-1 H	30	3	35.25	58.25	4.88	39.75	50.75	15.38	13.13	7.00	1.25	11.00	5.50	11.50	9.13	56.88	—	—	—	—	—	—	—
CR 45-4 H	30	3	35.25	58.25	4.88	39.75	50.75	15.38	13.13	7.00	1.25	11.00	5.50	11.50	9.13	56.88	—	—	—	—	—	—	—
CR 45-5-2 H	40	3	38.50	61.38	4.88	43.00	54.00	15.38	10.50	7.00	1.25	11.00	5.50	13.25	10.00	61.50	—	—	—	—	—	—	—
CR 45-5-1 H	40	3	38.50	61.38	4.88	43.00	54.00	15.38	10.50	7.00	1.25	11.00	5.50	13.25	10.00	61.50	—	—	—	—	—	—	—
CR 45-5 H	40	3	38.50	61.38	4.88	43.00	54.00	15.38	10.50	7.00	1.25	11.00	5.50	13.25	10.00	61.50	—	—	—	—	—	—	—
CR 45-6-2 H	50	3	41.63	69.13	4.88	46.63	58.63	17.00	11.75	8.00	0.25	12.00	6.25	13.25	10.00	64.13	—	—	—	—	—	—	—
CR 45-6 H	50	3	41.63	69.13	4.88	46.63	58.63	17.00	11.75	8.00	0.25	12.00	6.25	13.25	10.00	64.13	—	—	—	—	—	—	—
CR 45-7-2 H	50	3	44.75	72.38	4.88	49.75	61.75	17.00	11.75	8.00	0.25	12.00	6.25	13.25	10.00	67.25	—	—	—	—	—	—	—
CR 45-7 H	60	3	44.75	75.25	4.88	50.38	61.63	19.00	13.13	9.00	-0.75	11.25	7.00	15.13	11.63	70.63	—	—	—	—	—	—	—
CR 45-8-1 H	60	3	47.88	78.50	4.88	53.50	64.75	19.00	13.13	9.00	-0.75	11.25	7.00	15.13	11.63	73.75	—	—	—	—	—	—	—

Note: Terminal box is on top of motor on 3-phase up to 10 hp. All other motors have terminal box on the side. Reference D2 dimension. Weights are based on pump with TEFC motor.

CR, CRE 45 H GB/G20/G50

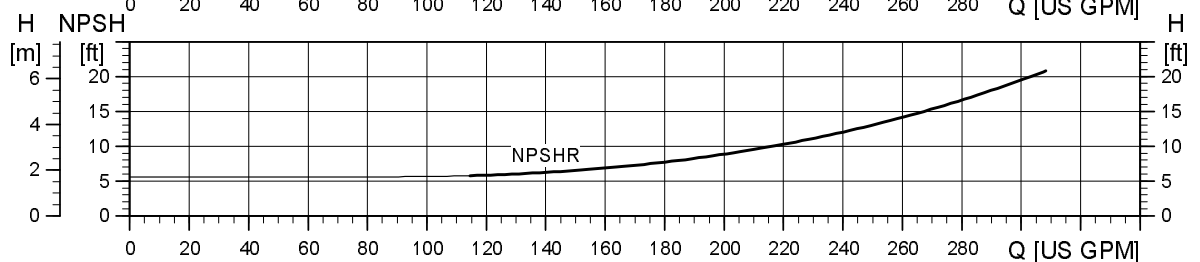
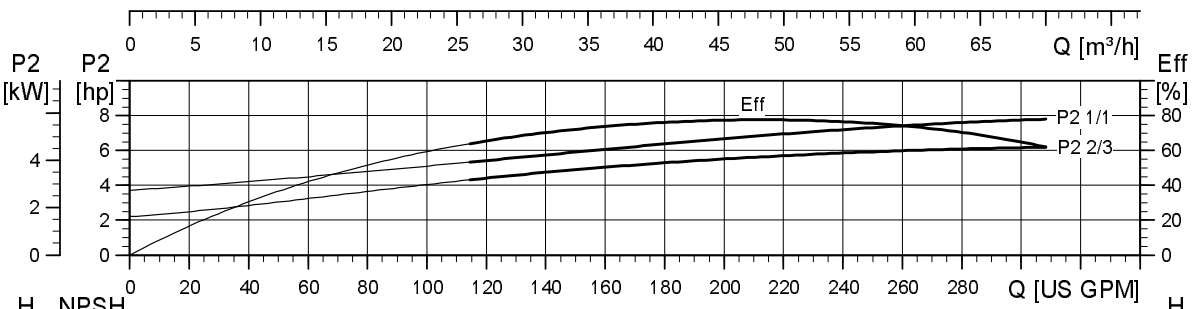
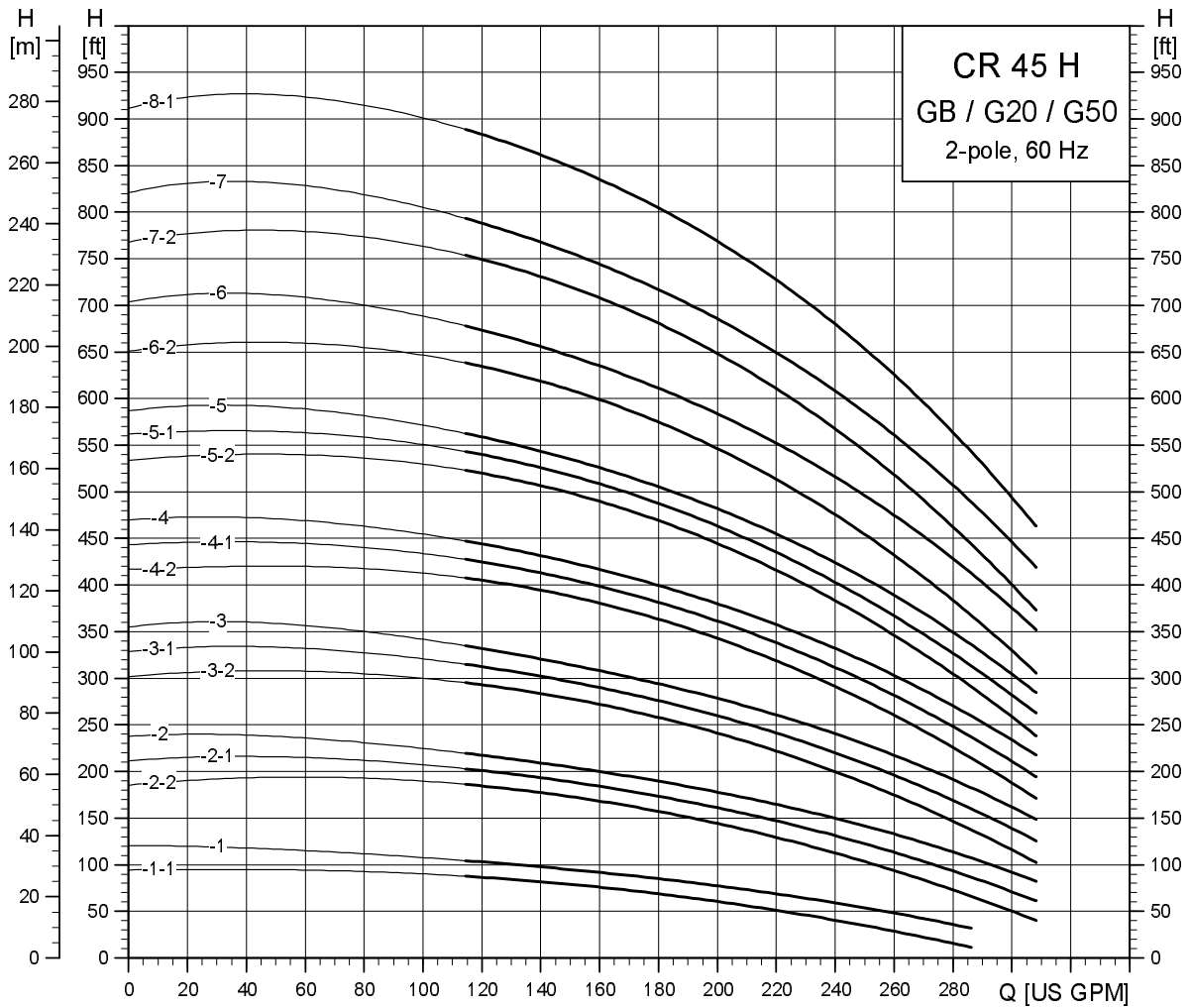

TM04 6296 0310

Dimensional sketches GB (3" x 1.5" x 6", 3" x 1.5" x 8")

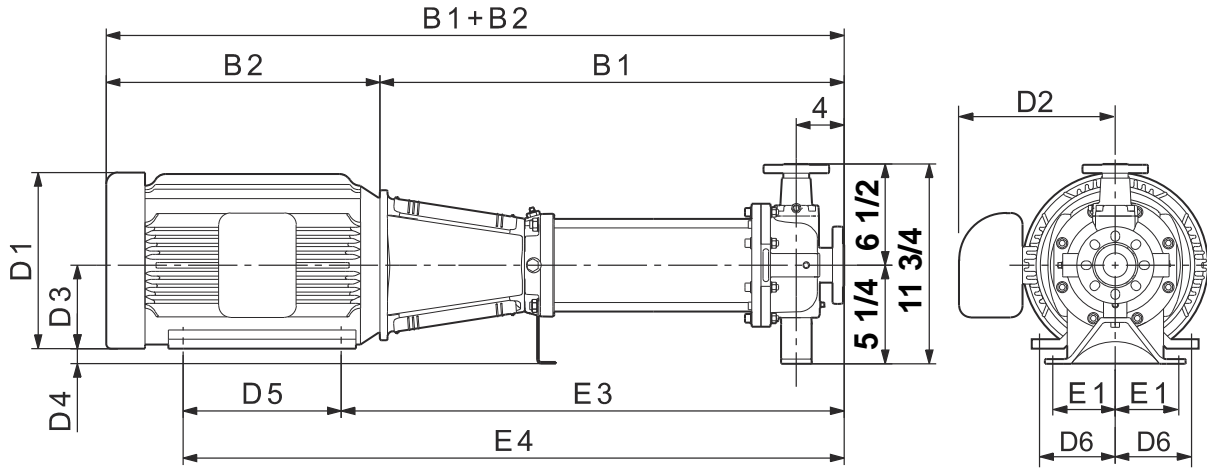

TM04 4872 0310

Dimensions and weights GB (3" x 1.5" x 6", 3" x 1.5" x 8")

Pump type	Power [hp]	Ph	Dimensions [inches]												Ship. weight [lbs]	Dimensions [inches]			Ship. weight [lbs]						
			TEFC													ODP				MLE					
			B1	B1+B2	E1	E3	E4	D1	D2	D3	D4	D5	D6	D1		D2	B1+B2	D1		D2	B1+B2				
CR(E) 45-1-1 H	7.5	1	27.13	42.38	3.00	30.38	35.88	10.25	7.63	5.25	0.00	5.50	4.25	—	—	—	—	—	—	—	—	—	—	—	—
		3	27.13	42.63	3.00	30.38	35.88	8.75	5.38	5.25	0.00	5.50	4.25	—	—	—	—	—	—	—	—	—	—	—	—
CR(E) 45-1 H	7.5	1	27.13	42.38	3.00	30.38	35.88	10.25	7.63	5.25	0.00	5.50	4.25	—	—	—	—	—	—	—	—	—	—	—	—
		3	27.13	42.63	3.00	30.38	35.88	8.75	5.38	5.25	0.00	5.50	4.25	—	—	—	—	—	—	—	—	—	—	—	—
CR 45-2-2 H	15	3	30.25	48.13	3.00	34.25	42.50	10.25	8.75	6.25	-1.00	8.25	5.00	10.63	6.88	46.38	—	—	—	—	—	—	—	—	—
CR 45-2-1 H	15	3	30.25	48.13	3.00	34.25	42.50	10.25	8.75	6.25	-1.00	8.25	5.00	10.63	6.88	46.38	—	—	—	—	—	—	—	—	—
CR 45-2 H	15	3	30.25	48.13	3.00	34.25	42.50	10.25	8.75	6.25	-1.00	8.25	5.00	10.63	6.88	46.38	—	—	—	—	—	—	—	—	—
CR 45-3-2 H	20	3	33.38	51.00	3.00	37.38	45.63	10.25	8.88	6.25	-1.00	8.25	5.00	11.50	9.13	52.88	—	—	—	—	—	—	—	—	—
CR 45-3-1 H	25	3	33.38	55.13	3.00	37.88	47.38	13.38	12.13	7.00	-1.75	9.50	5.50	11.50	9.13	54.00	—	—	—	—	—	—	—	—	—
CR 45-3 H	25	3	33.38	55.13	3.00	37.88	47.38	13.38	12.13	7.00	-1.75	9.50	5.50	11.50	9.13	54.00	—	—	—	—	—	—	—	—	—
CR 45-4-2 H	30	3	36.63	59.50	3.00	41.13	52.13	15.38	13.13	7.00	-1.75	11.00	5.50	11.50	9.13	58.13	—	—	—	—	—	—	—	—	—
CR 45-4-1 H	30	3	36.63	59.50	3.00	41.13	52.13	15.38	13.13	7.00	-1.75	11.00	5.50	11.50	9.13	58.13	—	—	—	—	—	—	—	—	—
CR 45-4 H	30	3	36.63	59.50	3.00	41.13	52.13	15.38	13.13	7.00	-1.75	11.00	5.50	11.50	9.13	58.13	—	—	—	—	—	—	—	—	—
CR 45-5-2 H	40	3	39.75	62.63	3.00	44.25	55.25	15.38	10.50	7.00	-1.75	11.00	5.50	13.25	10.00	62.75	—	—	—	—	—	—	—	—	—
CR 45-5-1 H	40	3	39.75	62.63	3.00	44.25	55.25	15.38	10.50	7.00	-1.75	11.00	5.50	13.25	10.00	62.75	—	—	—	—	—	—	—	—	—
CR 45-5 H	40	3	39.75	62.63	3.00	44.25	55.25	15.38	10.50	7.00	-1.75	11.00	5.50	13.25	10.00	62.75	—	—	—	—	—	—	—	—	—
CR 45-6-2 H	50	3	42.88	70.38	3.00	47.88	59.88	17.00	11.75	8.00	-2.75	12.00	6.25	13.25	10.00	65.38	—	—	—	—	—	—	—	—	—
CR 45-6 H	50	3	42.88	70.38	3.00	47.88	59.88	17.00	11.75	8.00	-2.75	12.00	6.25	13.25	10.00	65.38	—	—	—	—	—	—	—	—	—
CR 45-7-2 H	50	3	46.00	73.63	3.00	51.00	63.00	17.00	11.75	8.00	-2.75	12.00	6.25	13.25	10.00	68.50	—	—	—	—	—	—	—	—	—
CR 45-7 H	60	3	46.00	76.50	3.00	51.63	62.88	19.00	13.13	9.00	-3.75	11.25	7.00	15.13	11.63	71.88	—	—	—	—	—	—	—	—	—
CR 45-8-1 H	60	3	49.13	79.75	3.00	54.75	66.00	19.00	13.13	9.00	-3.75	11.25	7.00	15.13	11.63	75.00	—	—	—	—	—	—	—	—	—

Note: Terminal box is on top of motor on 3-phase up to 10 hp. All other motors have terminal box on the side. Reference D2 dimension. Weights are based on pump with TEFC motor.

Dimensional sketches G20 (3" x 1.5" x 13")

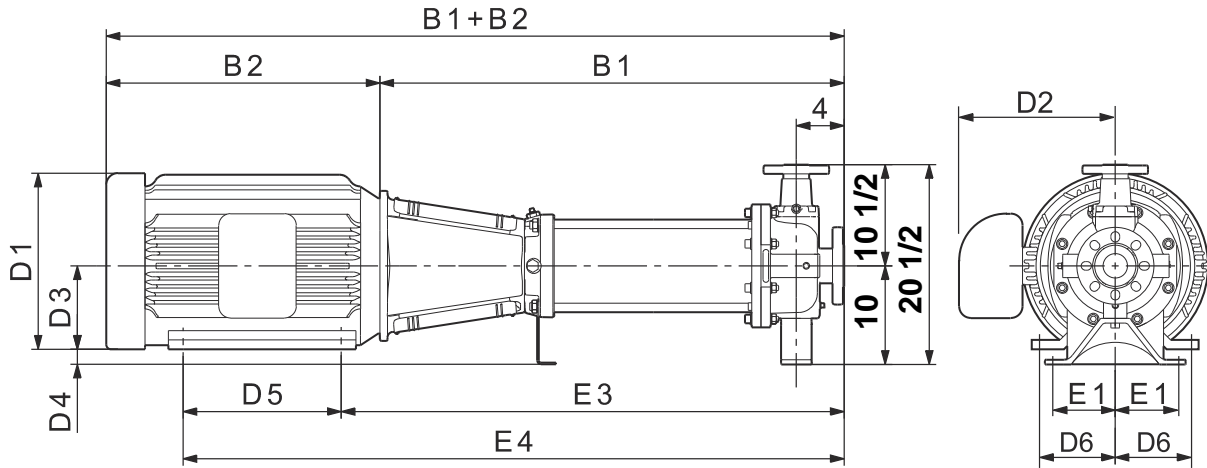

TM04 4872 0310

Dimensions and weights G20 (3" x 1.5" x 13")

Pump type	Power [hp]	Ph	Dimensions [inches]												Ship. weight [lbs]	Dimensions [inches]			Ship. weight [lbs]		
			TEFC										ODP			MLE					
			B1	B1+B2	E1	E3	E4	D1	D2	D3	D4	D5	D6	D1		D2	B1+B	D1		D2	B1+B
CR(E) 45-1-1 H	7.5	1	25.88	41.13	4.88	29.13	34.63	10.25	7.63	5.25	4.75	5.50	4.25	—	—	—	—	—	—	—	—
		3	25.88	41.38	4.88	29.13	34.63	8.75	5.38	5.25	4.75	5.50	4.25	—	—	—	—	8.75	7.50	41.38	—
CR(E) 45-1 H	7.5	1	25.88	41.13	4.88	29.13	34.63	10.25	7.63	5.25	4.75	5.50	4.25	—	—	—	—	—	—	—	—
		3	25.88	41.38	4.88	29.13	34.63	8.75	5.38	5.25	4.75	5.50	4.25	—	—	—	—	8.75	7.50	41.38	—
CR 45-2-2 H	15	3	29.00	46.88	4.88	33.00	41.25	10.25	8.75	6.25	3.75	8.25	5.00	10.63	6.88	45.13	—	—	—	—	—
CR 45-2-1 H	15	3	29.00	46.88	4.88	33.00	41.25	10.25	8.75	6.25	3.75	8.25	5.00	10.63	6.88	45.13	—	—	—	—	—
CR 45-2 H	15	3	29.00	46.88	4.88	33.00	41.25	10.25	8.75	6.25	3.75	8.25	5.00	10.63	6.88	45.13	—	—	—	—	—
CR 45-3-2 H	20	3	32.13	49.75	4.88	36.13	44.38	10.25	8.88	6.25	3.75	8.25	5.00	11.50	9.13	51.63	—	—	—	—	—
CR 45-3-1 H	25	3	32.13	53.88	4.88	36.63	46.13	13.38	12.13	7.00	3.00	9.50	5.50	11.50	9.13	52.75	—	—	—	—	—
CR 45-3 H	25	3	32.13	53.88	4.88	36.63	46.13	13.38	12.13	7.00	3.00	9.50	5.50	11.50	9.13	52.75	—	—	—	—	—
CR 45-4-2 H	30	3	35.25	58.25	4.88	39.75	50.75	15.38	13.13	7.00	3.00	11.00	5.50	11.50	9.13	56.88	—	—	—	—	—
CR 45-4-1 H	30	3	35.25	58.25	4.88	39.75	50.75	15.38	13.13	7.00	3.00	11.00	5.50	11.50	9.13	56.88	—	—	—	—	—
CR 45-4 H	30	3	35.25	58.25	4.88	39.75	50.75	15.38	13.13	7.00	3.00	11.00	5.50	11.50	9.13	56.88	—	—	—	—	—
CR 45-5-2 H	40	3	38.50	61.38	4.88	43.00	54.00	15.38	10.50	7.00	3.00	11.00	5.50	13.25	10.00	61.50	—	—	—	—	—
CR 45-5-1 H	40	3	38.50	61.38	4.88	43.00	54.00	15.38	10.50	7.00	3.00	11.00	5.50	13.25	10.00	61.50	—	—	—	—	—
CR 45-5 H	40	3	38.50	61.38	4.88	43.00	54.00	15.38	10.50	7.00	3.00	11.00	5.50	13.25	10.00	61.50	—	—	—	—	—
CR 45-6-2 H	50	3	41.63	69.13	4.88	46.63	58.63	17.00	11.75	8.00	2.00	12.00	6.25	13.25	10.00	64.13	—	—	—	—	—
CR 45-6 H	50	3	41.63	69.13	4.88	46.63	58.63	17.00	11.75	8.00	2.00	12.00	6.25	13.25	10.00	64.13	—	—	—	—	—
CR 45-7-2 H	50	3	44.75	72.38	4.88	49.75	61.75	17.00	11.75	8.00	2.00	12.00	6.25	13.25	10.00	67.25	—	—	—	—	—
CR 45-7 H	60	3	44.75	75.25	4.88	50.38	61.63	19.00	13.13	9.00	1.00	11.25	7.00	15.13	11.63	70.63	—	—	—	—	—
CR 45-8-1 H	60	3	47.88	78.50	4.88	53.50	64.75	19.00	13.13	9.00	1.00	11.25	7.00	15.13	11.63	73.75	—	—	—	—	—

Note: Terminal box is on top of motor on 3-phase up to 10 hp. All other motors have terminal box on the side. Reference D2 dimension. Weights are based on pump with TEFC motor.

Dimensional sketches G50 (3" x 1.5" x 8", 3" x 1.5" x 10")

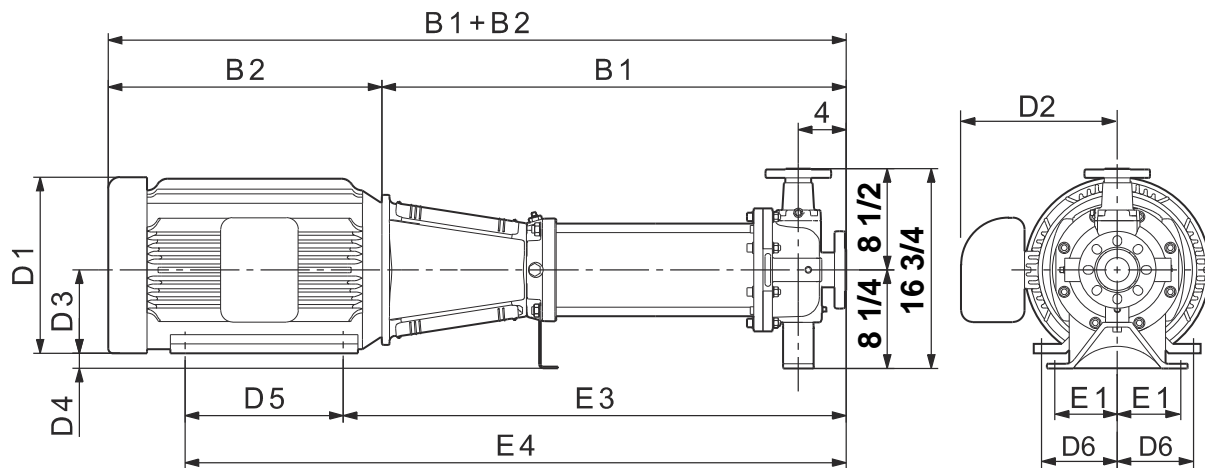

TM04 4872 0310

Dimensions and weights G50 (3" x 1.5" x 8", 3" x 1.5" x 10")

Pump type	Power [hp]	Ph	Dimensions [inches]													Ship. weight [lbs]	Dimensions [inches]			Ship. weight [lbs]
			TEFC										ODP				MLE			
			B1	B1+B2	E1	E3	E4	D1	D2	D3	D4	D5	D6	D1	D2		B1+B	D1	D2	
CR(E) 45-1-1 H	7.5	1	25.88	41.13	4.88	29.13	34.63	10.25	7.63	5.25	3.00	5.50	4.25	—	—	—	—	—	—	—
		3	25.88	41.38	4.88	29.13	34.63	8.75	5.38	5.25	3.00	5.50	4.25	—	—	—	—	8.75	7.50	41.38
CR(E) 45-1 H	7.5	1	25.88	41.13	4.88	29.13	34.63	10.25	7.63	5.25	3.00	5.50	4.25	—	—	—	—	—	—	—
		3	25.88	41.38	4.88	29.13	34.63	8.75	5.38	5.25	3.00	5.50	4.25	—	—	—	—	8.75	7.50	41.38
CR 45-2-2 H	15	3	29.00	46.88	4.88	33.00	41.25	10.25	8.75	6.25	2.00	8.25	5.00	10.63	6.88	45.13	—	—	—	—
CR 45-2-1 H	15	3	29.00	46.88	4.88	33.00	41.25	10.25	8.75	6.25	2.00	8.25	5.00	10.63	6.88	45.13	—	—	—	—
CR 45-2 H	15	3	29.00	46.88	4.88	33.00	41.25	10.25	8.75	6.25	2.00	8.25	5.00	10.63	6.88	45.13	—	—	—	—
CR 45-3-2 H	20	3	32.13	49.75	4.88	36.13	44.38	10.25	8.88	6.25	2.00	8.25	5.00	11.50	9.13	51.63	—	—	—	—
CR 45-3-1 H	25	3	32.13	53.88	4.88	36.63	46.13	13.38	12.13	7.00	1.25	9.50	5.50	11.50	9.13	52.75	—	—	—	—
CR 45-3 H	25	3	32.13	53.88	4.88	36.63	46.13	13.38	12.13	7.00	1.25	9.50	5.50	11.50	9.13	52.75	—	—	—	—
CR 45-4-2 H	30	3	35.25	58.25	4.88	39.75	50.75	15.38	13.13	7.00	1.25	11.00	5.50	11.50	9.13	56.88	—	—	—	—
CR 45-4-1 H	30	3	35.25	58.25	4.88	39.75	50.75	15.38	13.13	7.00	1.25	11.00	5.50	11.50	9.13	56.88	—	—	—	—
CR 45-4 H	30	3	35.25	58.25	4.88	39.75	50.75	15.38	13.13	7.00	1.25	11.00	5.50	11.50	9.13	56.88	—	—	—	—
CR 45-5-2 H	40	3	38.50	61.38	4.88	43.00	54.00	15.38	10.50	7.00	1.25	11.00	5.50	13.25	10.00	61.50	—	—	—	—
CR 45-5-1 H	40	3	38.50	61.38	4.88	43.00	54.00	15.38	10.50	7.00	1.25	11.00	5.50	13.25	10.00	61.50	—	—	—	—
CR 45-5 H	40	3	38.50	61.38	4.88	43.00	54.00	15.38	10.50	7.00	1.25	11.00	5.50	13.25	10.00	61.50	—	—	—	—
CR 45-6-2 H	50	3	41.63	69.13	4.88	46.63	58.63	17.00	11.75	8.00	0.25	12.00	6.25	13.25	10.00	64.13	—	—	—	—
CR 45-6 H	50	3	41.63	69.13	4.88	46.63	58.63	17.00	11.75	8.00	0.25	12.00	6.25	13.25	10.00	64.13	—	—	—	—
CR 45-7-2 H	50	3	44.75	72.38	4.88	49.75	61.75	17.00	11.75	8.00	0.25	12.00	6.25	13.25	10.00	67.25	—	—	—	—
CR 45-7 H	60	3	44.75	75.25	4.88	50.38	61.63	19.00	13.13	9.00	-0.75	11.25	7.00	15.13	11.63	70.63	—	—	—	—
CR 45-8-1 H	60	3	47.88	78.50	4.88	53.50	64.75	19.00	13.13	9.00	-0.75	11.25	7.00	15.13	11.63	73.75	—	—	—	—

Note: Terminal box is on top of motor on 3-phase up to 10 hp. All other motors have terminal box on the side. Reference D2 dimension. Weights are based on pump with TEFC motor.

CR, CRE 45 H GC/G10/G30/G60

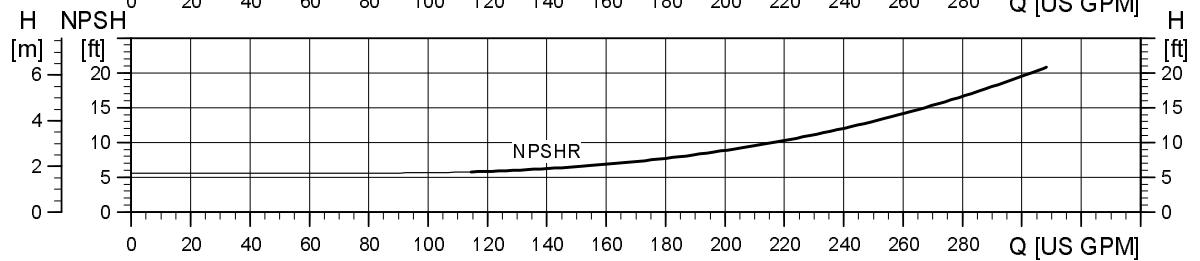
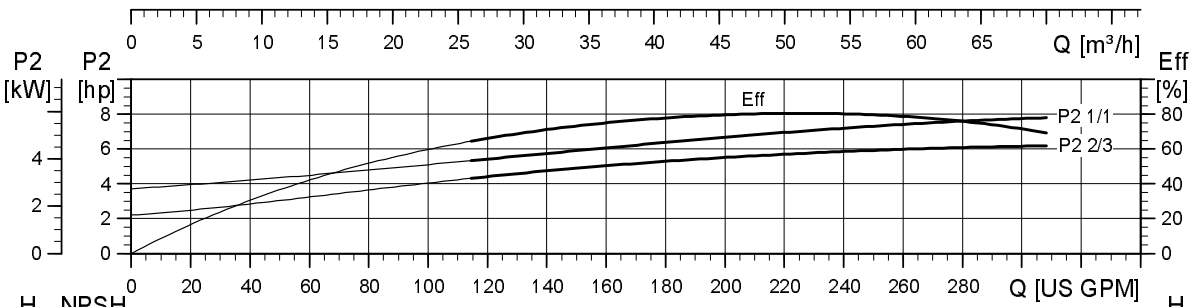
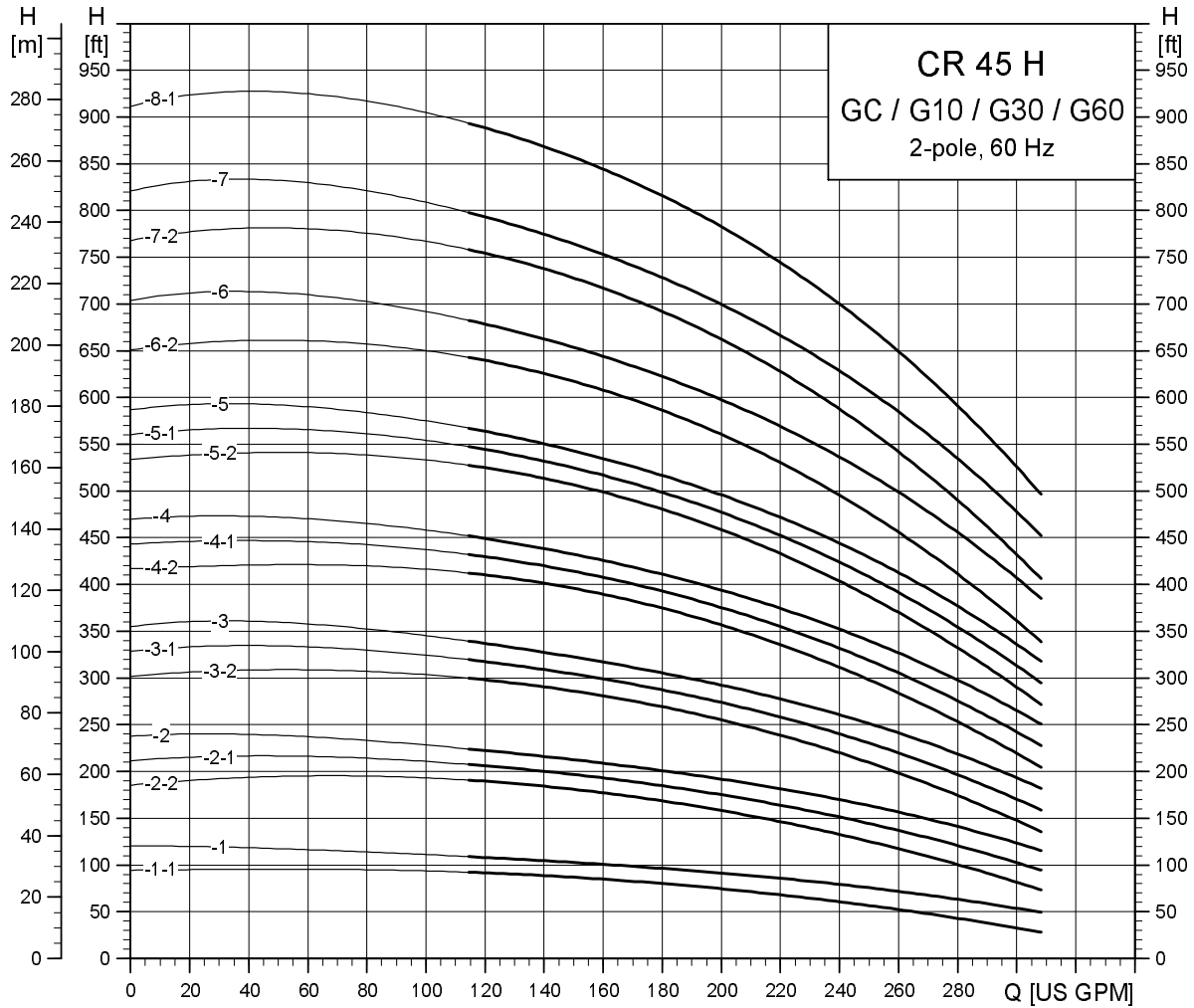

TM04 6297 0310

Dimensional sketches GC (3" x 2" x 6")

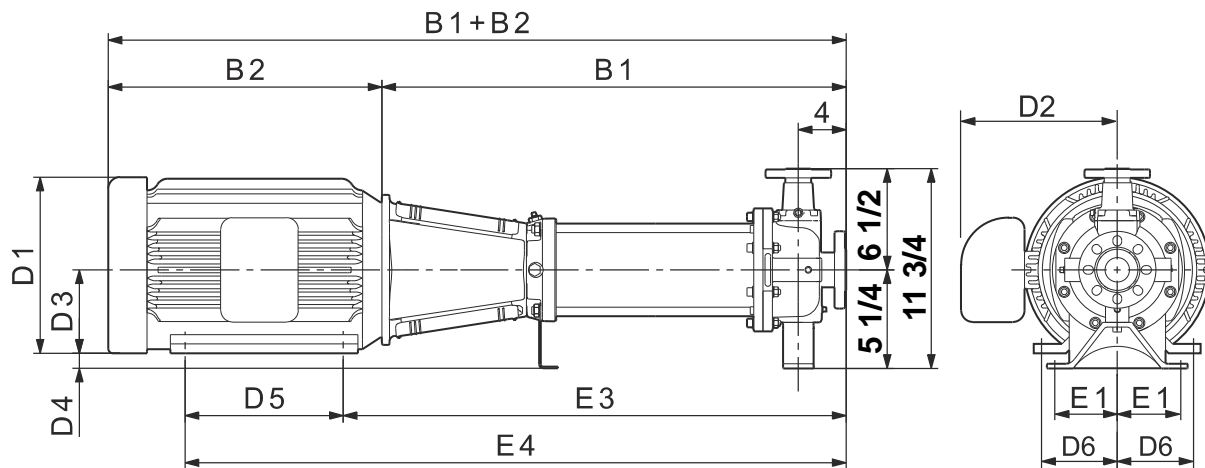

TM04 4872 0510

Dimensions and weights GC (3" x 2" x 6")

Pump type	Power [hp]	Ph	Dimensions [inches]												Ship. weight [lbs]	Dimensions [inches]			Ship. weight [lbs]		
			TEFC										ODP			MLE					
			B1	B1+B2	E1	E3	E4	D1	D2	D3	D4	D5	D6	D1		D2	B1+B2	D1		D2	B1+B2
CR(E) 45-1-1 H	7.5	1	27.13	42.38	3.00	30.38	35.88	10.25	7.63	5.25	0.00	5.50	4.25	—	—	—	—	—	—	—	—
		3	27.13	42.63	3.00	30.38	35.88	8.75	5.38	5.25	0.00	5.50	4.25	—	—	—	—	8.75	7.50	42.63	—
CR(E) 45-1 H	7.5	1	27.13	42.38	3.00	30.38	35.88	10.25	7.63	5.25	0.00	5.50	4.25	—	—	—	—	—	—	—	—
		3	27.13	42.63	3.00	30.38	35.88	8.75	5.38	5.25	0.00	5.50	4.25	—	—	—	—	8.75	7.50	42.63	—
CR 45-2-2 H	15	3	30.25	48.13	3.00	34.25	42.50	10.25	8.75	6.25	-1.00	8.25	5.00	10.63	6.88	46.38	—	—	—	—	—
CR 45-2-1 H	15	3	30.25	48.13	3.00	34.25	42.50	10.25	8.75	6.25	-1.00	8.25	5.00	10.63	6.88	46.38	—	—	—	—	—
CR 45-2 H	15	3	30.25	48.13	3.00	34.25	42.50	10.25	8.75	6.25	-1.00	8.25	5.00	10.63	6.88	46.38	—	—	—	—	—
CR 45-3-2 H	20	3	33.38	51.00	3.00	37.38	45.63	10.25	8.88	6.25	-1.00	8.25	5.00	11.50	9.13	52.88	—	—	—	—	—
CR 45-3-1 H	25	3	33.38	55.13	3.00	37.88	47.38	13.38	12.13	7.00	-1.75	9.50	5.50	11.50	9.13	54.00	—	—	—	—	—
CR 45-3 H	25	3	33.38	55.13	3.00	37.88	47.38	13.38	12.13	7.00	-1.75	9.50	5.50	11.50	9.13	54.00	—	—	—	—	—
CR 45-4-2 H	30	3	36.63	59.50	3.00	41.13	52.13	15.38	13.13	7.00	-1.75	11.00	5.50	11.50	9.13	58.13	—	—	—	—	—
CR 45-4-1 H	30	3	36.63	59.50	3.00	41.13	52.13	15.38	13.13	7.00	-1.75	11.00	5.50	11.50	9.13	58.13	—	—	—	—	—
CR 45-4 H	30	3	36.63	59.50	3.00	41.13	52.13	15.38	13.13	7.00	-1.75	11.00	5.50	11.50	9.13	58.13	—	—	—	—	—
CR 45-5-2 H	40	3	39.75	62.63	3.00	44.25	55.25	15.38	10.50	7.00	-1.75	11.00	5.50	13.25	10.00	62.75	—	—	—	—	—
CR 45-5-1 H	40	3	39.75	62.63	3.00	44.25	55.25	15.38	10.50	7.00	-1.75	11.00	5.50	13.25	10.00	62.75	—	—	—	—	—
CR 45-5 H	40	3	39.75	62.63	3.00	44.25	55.25	15.38	10.50	7.00	-1.75	11.00	5.50	13.25	10.00	62.75	—	—	—	—	—
CR 45-6-2 H	50	3	42.88	70.38	3.00	47.88	59.88	17.00	11.75	8.00	-2.75	12.00	6.25	13.25	10.00	65.38	—	—	—	—	—
CR 45-6 H	50	3	42.88	70.38	3.00	47.88	59.88	17.00	11.75	8.00	-2.75	12.00	6.25	13.25	10.00	65.38	—	—	—	—	—
CR 45-7-2 H	50	3	46.00	73.63	3.00	51.00	63.00	17.00	11.75	8.00	-2.75	12.00	6.25	13.25	10.00	68.50	—	—	—	—	—
CR 45-7 H	60	3	46.00	76.50	3.00	51.63	62.88	19.00	13.13	9.00	-3.75	11.25	7.00	15.13	11.63	71.88	—	—	—	—	—
CR 45-8-1 H	60	3	49.13	79.75	3.00	54.75	66.00	19.00	13.13	9.00	-3.75	11.25	7.00	15.13	11.63	75.00	—	—	—	—	—

Note: Terminal box is on top of motor on 3-phase up to 10 hp. All other motors have terminal box on the side. Reference D2 dimension. Weights are based on pump with TEFC motor.

Dimensional sketches G10 (3" x 2" x 6")

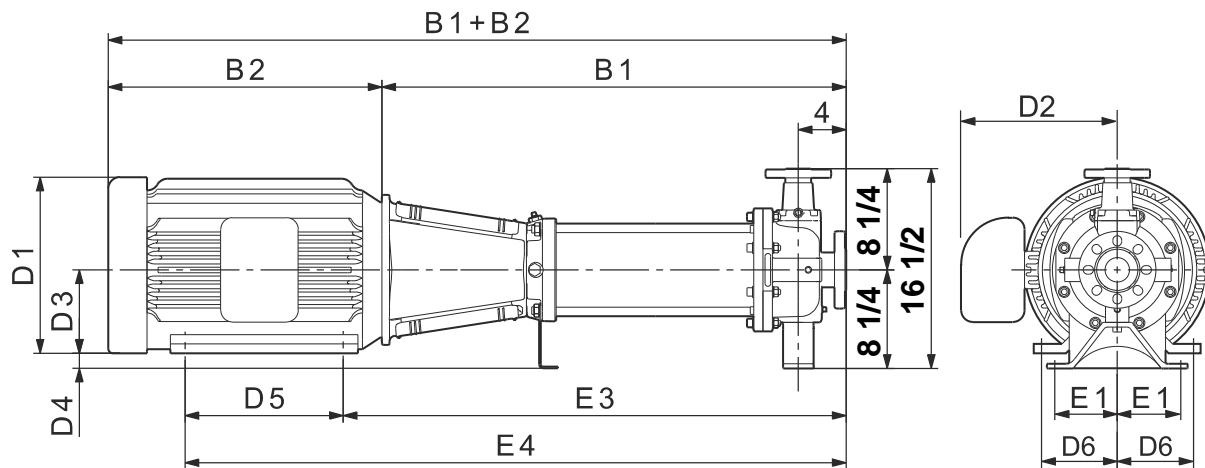

TM04 4872 0510

Dimensions and weights G10 (3" x 2" x 6")

Pump type	Power [hp]	Ph	Dimensions [inches]											Ship. weight [lbs]	Dimensions [inches]			Ship. weight [lbs]			
			TEFC												ODP				MLE		
			B1	B1+B	E1	E3	E4	D1	D2	D3	D4	D5	D6		D1	D2	B1+B		D1	D2	B1+B
CR(E) 45-1-1 H	7.5	1	25.88	41.13	4.88	29.13	34.63	10.25	7.63	5.25	3.00	5.50	4.25	—	—	—	—	—	—	—	—
		3	25.88	41.38	4.88	29.13	34.63	8.75	5.38	5.25	3.00	5.50	4.25	—	—	—	—	8.75	7.50	41.38	—
CR(E) 45-1 H	7.5	1	25.88	41.13	4.88	29.13	34.63	10.25	7.63	5.25	3.00	5.50	4.25	—	—	—	—	—	—	—	—
		3	25.88	41.38	4.88	29.13	34.63	8.75	5.38	5.25	3.00	5.50	4.25	—	—	—	—	8.75	7.50	41.38	—
CR 45-2-2 H	15	3	29.00	46.88	4.88	33.00	41.25	10.25	8.75	6.25	2.00	8.25	5.00	10.63	6.88	45.13	—	—	—	—	—
CR 45-2-1 H	15	3	29.00	46.88	4.88	33.00	41.25	10.25	8.75	6.25	2.00	8.25	5.00	10.63	6.88	45.13	—	—	—	—	—
CR 45-2 H	15	3	29.00	46.88	4.88	33.00	41.25	10.25	8.75	6.25	2.00	8.25	5.00	10.63	6.88	45.13	—	—	—	—	—
CR 45-3-2 H	20	3	32.13	49.75	4.88	36.13	44.38	10.25	8.88	6.25	2.00	8.25	5.00	11.50	9.13	51.63	—	—	—	—	—
CR 45-3-1 H	25	3	32.13	53.88	4.88	36.63	46.13	13.38	12.13	7.00	1.25	9.50	5.50	11.50	9.13	52.75	—	—	—	—	—
CR 45-3 H	25	3	32.13	53.88	4.88	36.63	46.13	13.38	12.13	7.00	1.25	9.50	5.50	11.50	9.13	52.75	—	—	—	—	—
CR 45-4-2 H	30	3	35.25	58.25	4.88	39.75	50.75	15.38	13.13	7.00	1.25	11.00	5.50	11.50	9.13	56.88	—	—	—	—	—
CR 45-4-1 H	30	3	35.25	58.25	4.88	39.75	50.75	15.38	13.13	7.00	1.25	11.00	5.50	11.50	9.13	56.88	—	—	—	—	—
CR 45-4 H	30	3	35.25	58.25	4.88	39.75	50.75	15.38	13.13	7.00	1.25	11.00	5.50	11.50	9.13	56.88	—	—	—	—	—
CR 45-5-2 H	40	3	38.50	61.38	4.88	43.00	54.00	15.38	10.50	7.00	1.25	11.00	5.50	13.25	10.00	61.50	—	—	—	—	—
CR 45-5-1 H	40	3	38.50	61.38	4.88	43.00	54.00	15.38	10.50	7.00	1.25	11.00	5.50	13.25	10.00	61.50	—	—	—	—	—
CR 45-5 H	40	3	38.50	61.38	4.88	43.00	54.00	15.38	10.50	7.00	1.25	11.00	5.50	13.25	10.00	61.50	—	—	—	—	—
CR 45-6-2 H	50	3	41.63	69.13	4.88	46.63	58.63	17.00	11.75	8.00	0.25	12.00	6.25	13.25	10.00	64.13	—	—	—	—	—
CR 45-6 H	50	3	41.63	69.13	4.88	46.63	58.63	17.00	11.75	8.00	0.25	12.00	6.25	13.25	10.00	64.13	—	—	—	—	—
CR 45-7-2 H	50	3	44.75	72.38	4.88	49.75	61.75	17.00	11.75	8.00	0.25	12.00	6.25	13.25	10.00	67.25	—	—	—	—	—
CR 45-7 H	60	3	44.75	75.25	4.88	50.38	61.63	19.00	13.13	9.00	-0.75	11.25	7.00	15.13	11.63	70.63	—	—	—	—	—
CR 45-8-1 H	60	3	47.88	78.50	4.88	53.50	64.75	19.00	13.13	9.00	-0.75	11.25	7.00	15.13	11.63	73.75	—	—	—	—	—

Note: Terminal box is on top of motor on 3-phase up to 10 hp. All other motors have terminal box on the side. Reference D2 dimension. Weights are based on pump with TEFC motor.

Dimensional sketches G30 (3" x 2" x 13")

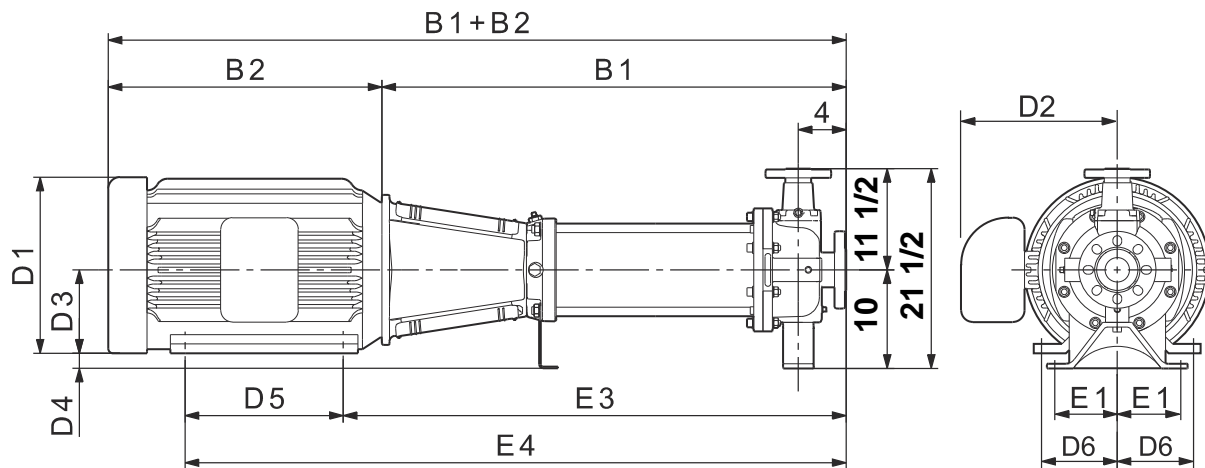

Dimensions and weights G30 (3" x 2" x 13")

Pump type	Power [hp]	Ph	Dimensions [inches]										Ship. weight [lbs]	Dimensions [inches]			Ship. weight [lbs]				
			TEFC											ODP				MLE			
			B1	B1+B	E1	E3	E4	D1	D2	D3	D4	D5		D6	D1	D2		B1+B2	D1	D2	B1+B
CR(E) 45-1-1 H	7.5	1	25.88	41.13	4.88	29.13	34.63	10.25	7.63	5.25	4.75	5.50	4.25	—	—	—	—	5.63	5.63	35.00	—
		3	25.88	41.38	4.88	29.13	34.63	8.75	5.38	5.25	4.75	5.50	4.25	—	—	—	—	8.75	7.50	41.38	—
CR(E) 45-1 H	7.5	1	25.88	41.13	4.88	29.13	34.63	10.25	7.63	5.25	4.75	5.50	4.25	—	—	—	—	5.63	5.63	35.00	—
		3	25.88	41.38	4.88	29.13	34.63	8.75	5.38	5.25	4.75	5.50	4.25	—	—	—	—	8.75	7.50	41.38	—
CR 45-2-2 H	15	3	29.00	46.88	4.88	33.00	41.25	10.25	8.75	6.25	3.75	8.25	5.00	10.63	6.88	45.13	—	—	—	—	—
CR 45-2-1 H	15	3	29.00	46.88	4.88	33.00	41.25	10.25	8.75	6.25	3.75	8.25	5.00	10.63	6.88	45.13	—	—	—	—	—
CR 45-2 H	15	3	29.00	46.88	4.88	33.00	41.25	10.25	8.75	6.25	3.75	8.25	5.00	10.63	6.88	45.13	—	—	—	—	—
CR 45-3-2 H	20	3	32.13	49.75	4.88	36.13	44.38	10.25	8.88	6.25	3.75	8.25	5.00	11.50	9.13	51.63	—	—	—	—	—
CR 45-3-1 H	25	3	32.13	53.88	4.88	36.63	46.13	13.38	12.13	7.00	3.00	9.50	5.50	11.50	9.13	52.75	—	—	—	—	—
CR 45-3 H	25	3	32.13	53.88	4.88	36.63	46.13	13.38	12.13	7.00	3.00	9.50	5.50	11.50	9.13	52.75	—	—	—	—	—
CR 45-4-2 H	30	3	35.25	58.25	4.88	39.75	50.75	15.38	13.13	7.00	3.00	11.00	5.50	11.50	9.13	56.88	—	—	—	—	—
CR 45-4-1 H	30	3	35.25	58.25	4.88	39.75	50.75	15.38	13.13	7.00	3.00	11.00	5.50	11.50	9.13	56.88	—	—	—	—	—
CR 45-4 H	30	3	35.25	58.25	4.88	39.75	50.75	15.38	13.13	7.00	3.00	11.00	5.50	11.50	9.13	56.88	—	—	—	—	—
CR 45-5-2 H	40	3	38.50	61.38	4.88	43.00	54.00	15.38	10.50	7.00	3.00	11.00	5.50	13.25	10.00	61.50	—	—	—	—	—
CR 45-5-1 H	40	3	38.50	61.38	4.88	43.00	54.00	15.38	10.50	7.00	3.00	11.00	5.50	13.25	10.00	61.50	—	—	—	—	—
CR 45-5 H	40	3	38.50	61.38	4.88	43.00	54.00	15.38	10.50	7.00	3.00	11.00	5.50	13.25	10.00	61.50	—	—	—	—	—
CR 45-6-2 H	50	3	41.63	69.13	4.88	46.63	58.63	17.00	11.75	8.00	2.00	12.00	6.25	13.25	10.00	64.13	—	—	—	—	—
CR 45-6 H	50	3	41.63	69.13	4.88	46.63	58.63	17.00	11.75	8.00	2.00	12.00	6.25	13.25	10.00	64.13	—	—	—	—	—
CR 45-7-2 H	50	3	44.75	72.38	4.88	49.75	61.75	17.00	11.75	8.00	2.00	12.00	6.25	13.25	10.00	67.25	—	—	—	—	—
CR 45-7 H	60	3	44.75	75.25	4.88	50.38	61.63	19.00	13.13	9.00	1.00	11.25	7.00	15.13	11.63	70.63	—	—	—	—	—
CR 45-8-1 H	60	3	47.88	78.50	4.88	53.50	64.75	19.00	13.13	9.00	1.00	11.25	7.00	15.13	11.63	73.75	—	—	—	—	—

Note: Terminal box is on top of motor on 3-phase up to 10 hp. All other motors have terminal box on the side. Reference D2 dimension. Weights are based on pump with TEFC motor.

Dimensional sketches G60 (3" x 2" x 8", 3" x 2" x 10")

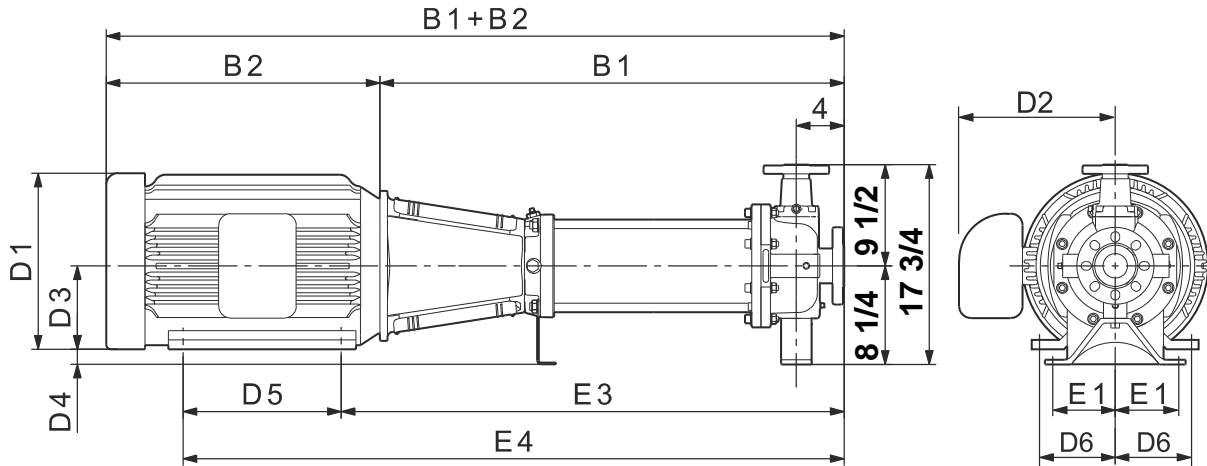

TM04 4872 0510

Dimensions and weights G60 (3" x 2" x 8", 3" x 2" x 10")

Pump type	Power [hp]	Ph	Dimensions [inches]										Ship. weight [lbs]	Dimensions [inches]			Ship. weight [lbs]				
			TEFC											ODP				MLE			
			B1	B1+B2	E1	E3	E4	D1	D2	D3	D4	D5		D6	D1	D2		B1+B2	D1	D2	B1+B2
CR(E) 45-1-1 H	7.5	1	25.88	41.13	4.88	29.13	34.63	10.25	7.63	5.25	3.00	5.50	4.25	—	—	—	—	—	—	—	—
		3	25.88	41.38	4.88	29.13	34.63	8.75	5.38	5.25	3.00	5.50	4.25	—	—	—	—	8.75	7.50	41.38	—
CR(E) 45-1 H	7.5	1	25.88	41.13	4.88	29.13	34.63	10.25	7.63	5.25	3.00	5.50	4.25	—	—	—	—	—	—	—	—
		3	25.88	41.38	4.88	29.13	34.63	8.75	5.38	5.25	3.00	5.50	4.25	—	—	—	—	—	8.75	7.50	41.38
CR 45-2-2 H	15	3	29.00	46.88	4.88	33.00	41.25	10.25	8.75	6.25	2.00	8.25	5.00	10.63	6.88	45.13	—	—	—	—	—
CR 45-2-1 H	15	3	29.00	46.88	4.88	33.00	41.25	10.25	8.75	6.25	2.00	8.25	5.00	10.63	6.88	45.13	—	—	—	—	—
CR 45-2 H	15	3	29.00	46.88	4.88	33.00	41.25	10.25	8.75	6.25	2.00	8.25	5.00	10.63	6.88	45.13	—	—	—	—	—
CR 45-3-2 H	20	3	32.13	49.75	4.88	36.13	44.38	10.25	8.88	6.25	2.00	8.25	5.00	11.50	9.13	51.63	—	—	—	—	—
CR 45-3-1 H	25	3	32.13	53.88	4.88	36.63	46.13	13.38	12.13	7.00	1.25	9.50	5.50	11.50	9.13	52.75	—	—	—	—	—
CR 45-3 H	25	3	32.13	53.88	4.88	36.63	46.13	13.38	12.13	7.00	1.25	9.50	5.50	11.50	9.13	52.75	—	—	—	—	—
CR 45-4-2 H	30	3	35.25	58.25	4.88	39.75	50.75	15.38	13.13	7.00	1.25	11.00	5.50	11.50	9.13	56.88	—	—	—	—	—
CR 45-4-1 H	30	3	35.25	58.25	4.88	39.75	50.75	15.38	13.13	7.00	1.25	11.00	5.50	11.50	9.13	56.88	—	—	—	—	—
CR 45-4 H	30	3	35.25	58.25	4.88	39.75	50.75	15.38	13.13	7.00	1.25	11.00	5.50	11.50	9.13	56.88	—	—	—	—	—
CR 45-5-2 H	40	3	38.50	61.38	4.88	43.00	54.00	15.38	10.50	7.00	1.25	11.00	5.50	13.25	10.00	61.50	—	—	—	—	—
CR 45-5-1 H	40	3	38.50	61.38	4.88	43.00	54.00	15.38	10.50	7.00	1.25	11.00	5.50	13.25	10.00	61.50	—	—	—	—	—
CR 45-5 H	40	3	38.50	61.38	4.88	43.00	54.00	15.38	10.50	7.00	1.25	11.00	5.50	13.25	10.00	61.50	—	—	—	—	—
CR 45-6-2 H	50	3	41.63	69.13	4.88	46.63	58.63	17.00	11.75	8.00	0.25	12.00	6.25	13.25	10.00	64.13	—	—	—	—	—
CR 45-6 H	50	3	41.63	69.13	4.88	46.63	58.63	17.00	11.75	8.00	0.25	12.00	6.25	13.25	10.00	64.13	—	—	—	—	—
CR 45-7-2 H	50	3	44.75	72.38	4.88	49.75	61.75	17.00	11.75	8.00	0.25	12.00	6.25	13.25	10.00	67.25	—	—	—	—	—
CR 45-7 H	60	3	44.75	75.25	4.88	50.38	61.63	19.00	13.13	9.00	-0.75	11.25	7.00	15.13	11.63	70.63	—	—	—	—	—
CR 45-8-1 H	60	3	47.88	78.50	4.88	53.50	64.75	19.00	13.13	9.00	-0.75	11.25	7.00	15.13	11.63	73.75	—	—	—	—	—

Note: Terminal box is on top of motor on 3-phase up to 10 hp. All other motors have terminal box on the side. Reference D2 dimension. Weights are based on pump with TEFC motor.

CR, CRE 64 H G44

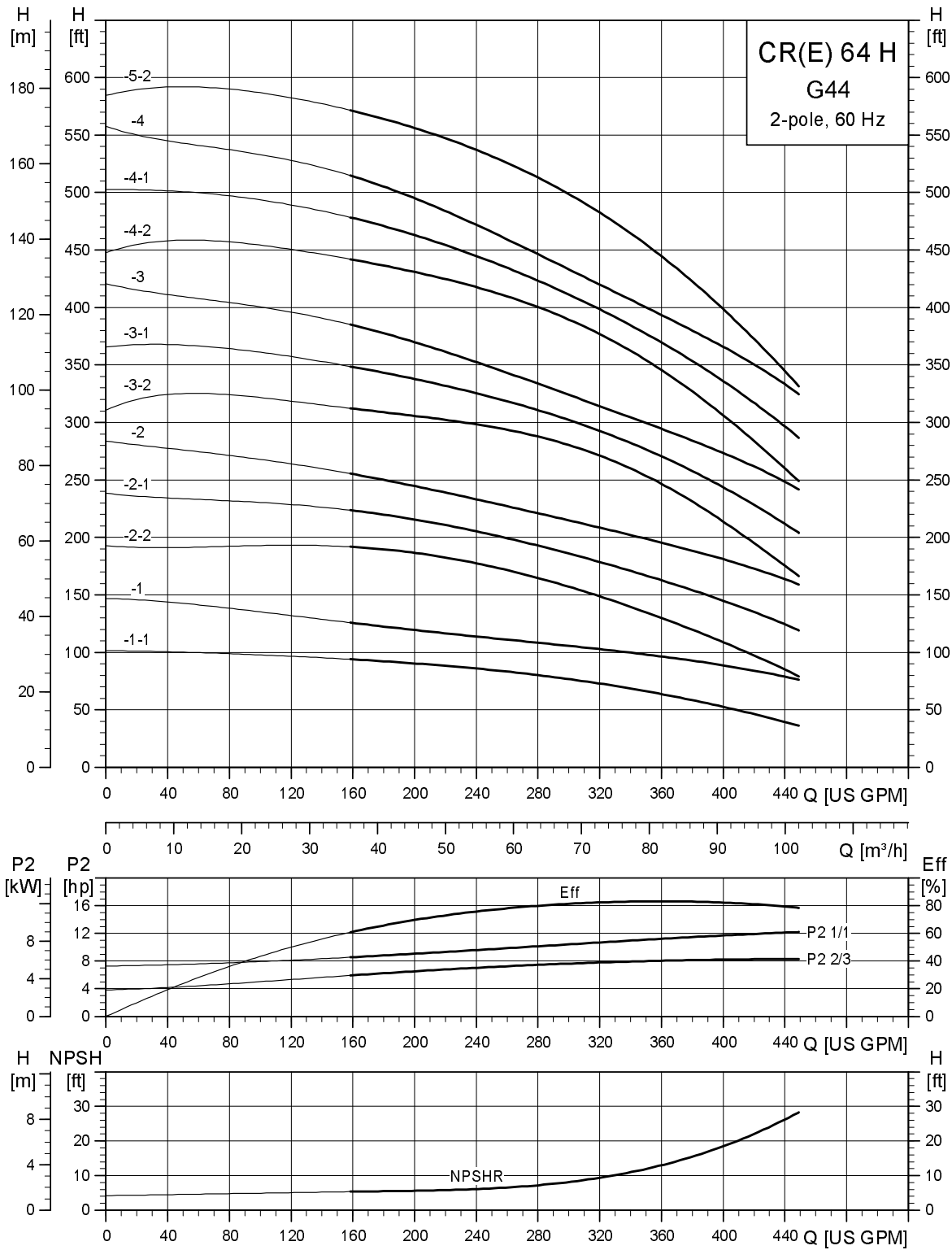

TM04 6302 0310

Dimensional sketches G44 (4" x 4")

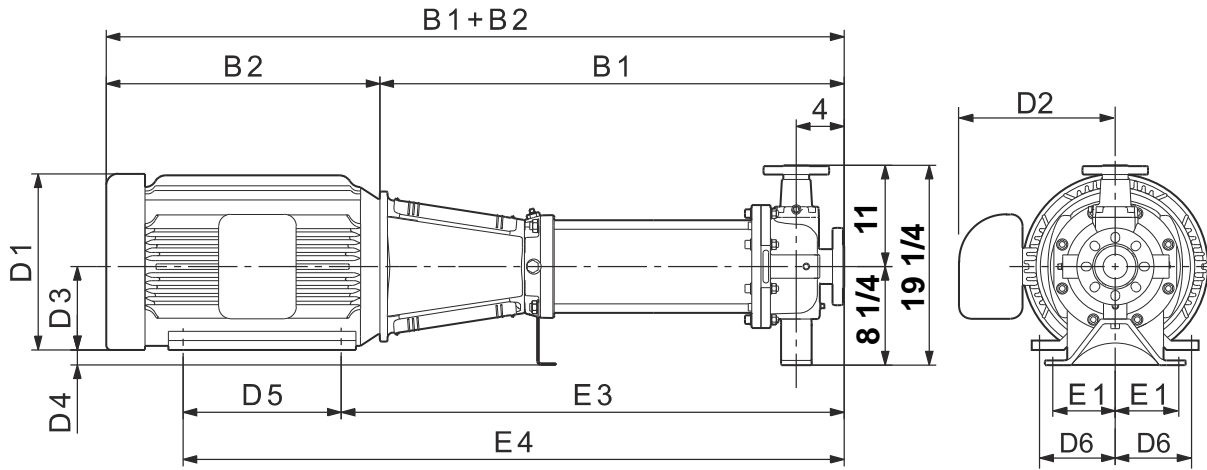

TM04 4872 0510

Dimensions and weights G44 (4" x 4")

Pump type	Power [hp]	Ph	Dimensions [inches]										Ship. weight [lbs]	Dimensions [inches]			Ship. weight [lbs]				
			TEFC											ODP				MLE			
			B1	B1+B2	E1	E3	E4	D1	D2	D3	D4	D5		D6	D1	D2		B1+B2	D1	D2	B1+B2
CR(E) 64-1-1 H	7.5	1	27.13	42.38	4.88	30.38	35.88	10.25	7.63	5.25	3.00	5.50	4.25	—	—	—	—	—	—	—	—
		3	27.13	42.63	4.88	30.38	35.88	8.75	5.38	5.25	3.00	5.50	4.25	—	—	—	—	8.75	7.50	42.63	—
CR 64-1 H	15	3	27.13	45.00	4.88	31.13	39.38	10.25	8.75	6.25	2.00	8.25	5.00	10.63	6.88	43.13	—	—	—	—	—
CR 64-2-2 H	15	3	30.38	48.25	4.88	34.38	42.63	10.25	8.75	6.25	2.00	8.25	5.00	10.63	6.88	46.38	—	—	—	—	—
CR 64-2-1 H	20	3	30.38	47.88	4.88	34.38	42.63	10.25	8.88	6.25	2.00	8.25	5.00	11.50	9.13	49.75	—	—	—	—	—
CR 64-2 H	25	3	30.38	52.00	4.88	34.88	44.38	13.38	12.13	7.00	1.25	9.50	5.50	11.50	9.13	50.88	—	—	—	—	—
CR 64-3-2 H	30	3	33.63	56.50	4.88	38.13	49.13	15.38	13.13	7.00	1.25	11.00	5.50	11.50	9.13	55.13	—	—	—	—	—
CR 64-3-1 H	40	3	33.63	56.50	4.88	38.13	49.13	15.38	10.50	7.00	1.25	11.00	5.50	13.25	10.00	56.63	—	—	—	—	—
CR 64-3 H	40	3	33.63	56.50	4.88	38.13	49.13	15.38	10.50	7.00	1.25	11.00	5.50	13.25	10.00	56.63	—	—	—	—	—
CR 64-4-2 H	40	3	36.88	59.75	4.88	41.38	52.38	15.38	10.50	7.00	1.25	11.00	5.50	13.25	10.00	59.88	—	—	—	—	—
CR 64-4-1 H	50	3	36.88	64.38	4.88	41.88	53.88	17.00	11.75	8.00	0.25	12.00	6.25	13.25	10.00	59.38	—	—	—	—	—
CR 64-4 H	50	3	36.88	64.38	4.88	41.88	53.88	17.00	11.75	8.00	0.25	12.00	6.25	13.25	10.00	59.38	—	—	—	—	—
CR 64-5-2 H	60	3	40.13	70.63	4.88	45.75	57.00	19.00	13.13	9.00	0.75	11.25	7.00	15.13	11.63	66.00	—	—	—	—	—

Note: Terminal box is on top of motor on 3-phase up to 10 hp. All other motors have terminal box on the side. Reference D2 dimension. Weights are based on pump with TEFC motor.

CR, CRE 64 H GC/G10/G30/G60

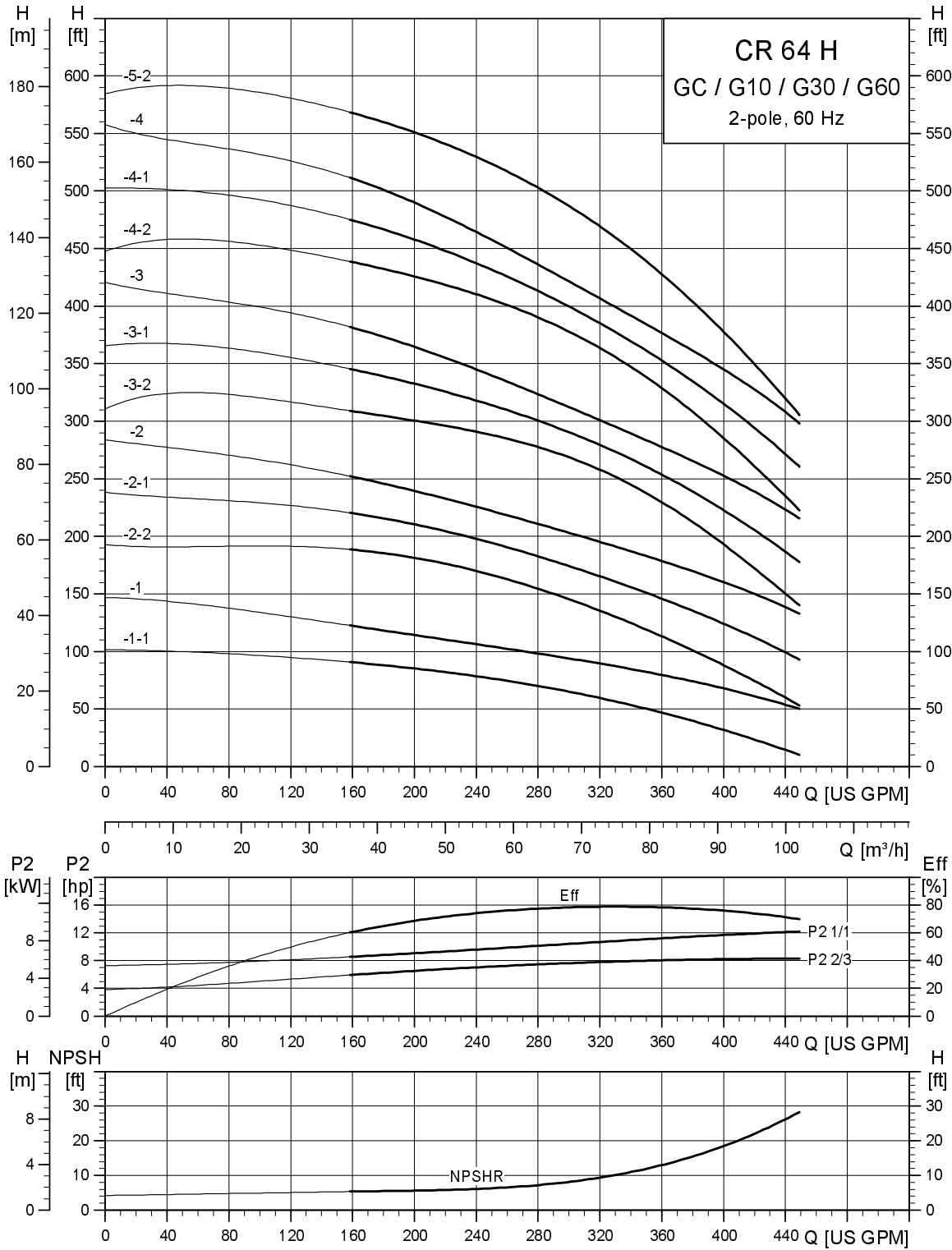

TM04 6300 0310

Dimensional sketches GC (3" x 2" x 6")

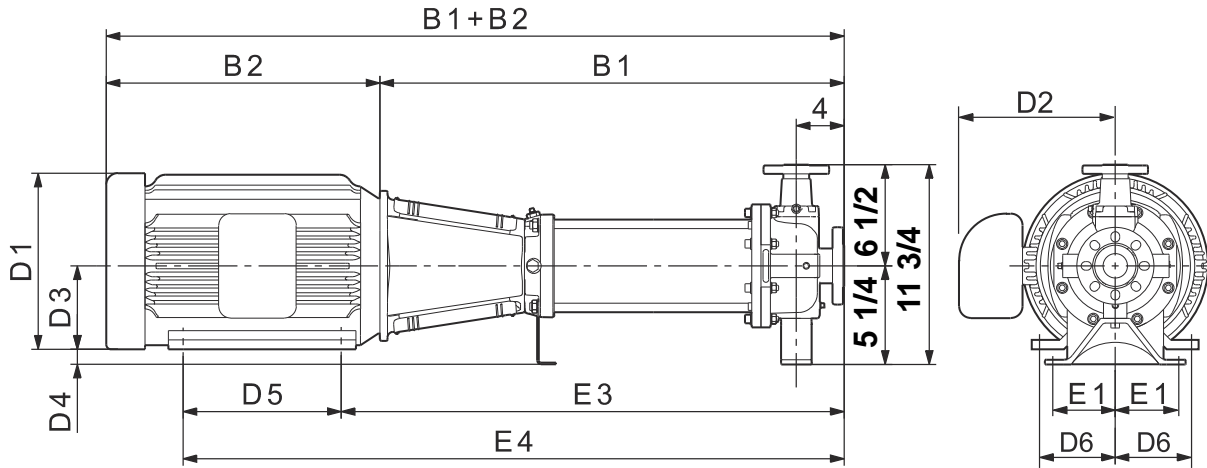

TM04 4872 0510

Dimensions and weights GC (3" x 2" x 6")

Pump type	Power [hp]	Ph	Dimensions [inches]											Ship. weight [lbs]	Dimensions			Ship. weight [lbs]					
			TEFC												ODP				MLE				
			B1	B1+B	E1	E3	E4	D1	D2	D3	D4	D5	D6		D1	D2	B1+B		D1	D2	B1+B		
CR(E) 64-1-1 H	7.5	1	27.25	42.50	3.00	30.50	36.00	10.25	7.63	5.25	0.00	5.50	4.25	—	—	—	—	—	—	—	—	—	
		3	27.25	42.75	3.00	30.50	36.00	8.75	5.38	5.25	0.00	5.50	4.25	—	—	—	—	8.75	7.50	42.75	—	—	—
CR 64-1 H	15	3	27.25	45.13	3.00	31.25	39.50	10.25	8.75	6.25	-1.00	8.25	5.00	10.63	6.88	43.25	—	—	—	—	—	—	—
CR 64-2-2 H	15	3	30.50	48.38	3.00	34.50	42.75	10.25	8.75	6.25	-1.00	8.25	5.00	10.63	6.88	46.50	—	—	—	—	—	—	—
CR 64-2-1 H	20	3	30.50	48.00	3.00	34.50	42.75	10.25	8.88	6.25	-1.00	8.25	5.00	11.50	9.13	49.88	—	—	—	—	—	—	—
CR 64-2 H	25	3	30.50	52.13	3.00	35.00	44.50	13.38	12.13	7.00	-1.75	9.50	5.50	11.50	9.13	51.00	—	—	—	—	—	—	—
CR 64-3-2 H	30	3	33.75	56.63	3.00	38.25	49.25	15.38	13.13	7.00	-1.75	11.00	5.50	11.50	9.13	55.25	—	—	—	—	—	—	—
CR 64-3-1 H	40	3	33.75	56.63	3.00	38.25	49.25	15.38	10.50	7.00	-1.75	11.00	5.50	13.25	10.00	56.75	—	—	—	—	—	—	—
CR 64-3 H	40	3	33.75	56.63	3.00	38.25	49.25	15.38	10.50	7.00	-1.75	11.00	5.50	13.25	10.00	56.75	—	—	—	—	—	—	—
CR 64-4-2 H	40	3	37.00	59.88	3.00	41.50	52.50	15.38	10.50	7.00	-1.75	11.00	5.50	13.25	10.00	60.00	—	—	—	—	—	—	—
CR 64-4-1 H	50	3	37.00	64.50	3.00	42.00	54.00	17.00	11.75	8.00	-2.75	12.00	6.25	13.25	10.00	59.50	—	—	—	—	—	—	—
CR 64-4 H	50	3	37.00	64.50	3.00	42.00	54.00	17.00	11.75	8.00	-2.75	12.00	6.25	13.25	10.00	59.50	—	—	—	—	—	—	—
CR 64-5-2 H	60	3	40.25	70.75	3.00	45.88	57.13	19.00	13.13	9.00	-3.75	11.25	7.00	15.13	11.63	66.13	—	—	—	—	—	—	—

Note: Terminal box is on top of motor on 3-phase up to 10 hp. All other motors have terminal box on the side. Reference D2 dimension. Weights are based on pump with TEFC motor.

Dimensional sketches G10 (3" x 2" x 6")

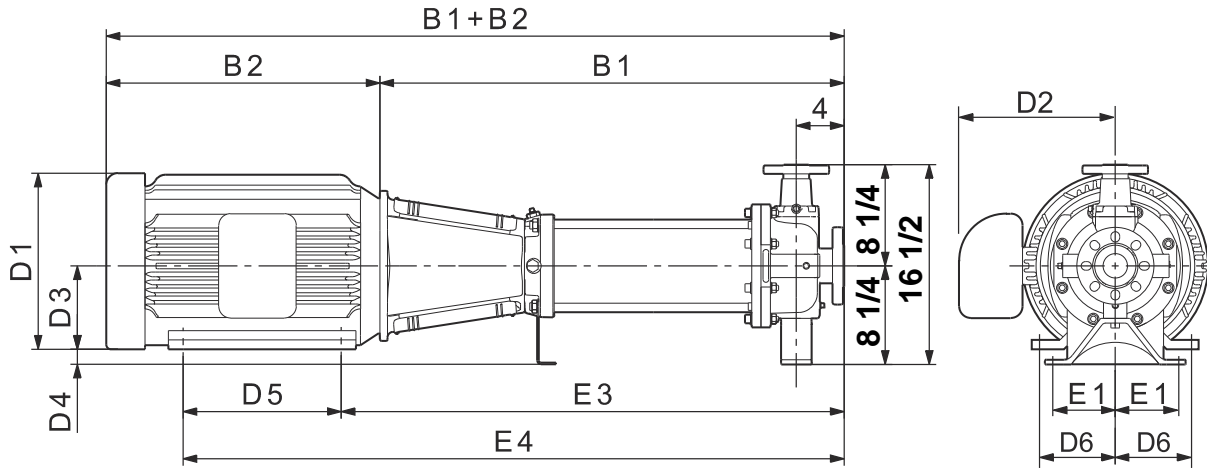

TM04 4872 0510

Dimensions and weights G10 (3" x 2" x 6")

Pump type	Power [hp]	Ph	Dimensions [inches]													Ship. weight [lbs]	Dimensions [inches]			Ship. weight [lbs]
			TEFC										ODP				MLE			
			B1	B1+B2	E1	E3	E4	D1	D2	D3	D4	D5	D6	D1	D2		B1+B2	D1	D2	
CR(E) 64-1-1 H	7.5	1	26.00	41.25	4.88	29.25	34.75	10.25	7.63	5.25	3.00	5.50	4.25	—	—	—	—	—	—	—
		3	26.00	41.50	4.88	29.25	34.75	8.75	5.38	5.25	3.00	5.50	4.25	—	—	—	—	8.75	7.50	41.50
CR 64-1 H	15	3	26.00	43.88	4.88	30.00	38.25	10.25	8.75	6.25	2.00	8.25	5.00	10.63	6.88	42.00	—	—	—	—
CR 64-2-2 H	15	3	29.25	47.13	4.88	33.25	41.50	10.25	8.75	6.25	2.00	8.25	5.00	10.63	6.88	45.25	—	—	—	—
CR 64-2-1 H	20	3	29.25	46.75	4.88	33.25	41.50	10.25	8.88	6.25	2.00	8.25	5.00	11.50	9.13	48.63	—	—	—	—
CR 64-2 H	25	3	29.25	50.88	4.88	33.75	43.25	13.38	12.13	7.00	1.25	9.50	5.50	11.50	9.13	49.75	—	—	—	—
CR 64-3-2 H	30	3	32.50	55.38	4.88	37.00	48.00	15.38	13.13	7.00	1.25	11.00	5.50	11.50	9.13	54.00	—	—	—	—
CR 64-3-1 H	40	3	32.50	55.38	4.88	37.00	48.00	15.38	10.50	7.00	1.25	11.00	5.50	13.25	10.00	55.50	—	—	—	—
CR 64-3 H	40	3	32.50	55.38	4.88	37.00	48.00	15.38	10.50	7.00	1.25	11.00	5.50	13.25	10.00	55.50	—	—	—	—
CR 64-4-2 H	40	3	35.75	58.63	4.88	40.25	51.25	15.38	10.50	7.00	1.25	11.00	5.50	13.25	10.00	58.75	—	—	—	—
CR 64-4-1 H	50	3	35.75	63.25	4.88	40.75	52.75	17.00	11.75	8.00	0.25	12.00	6.25	13.25	10.00	58.25	—	—	—	—
CR 64-4 H	50	3	35.75	63.25	4.88	40.75	52.75	17.00	11.75	8.00	0.25	12.00	6.25	13.25	10.00	58.25	—	—	—	—
CR 64-5-2 H	60	3	39.00	69.50	4.88	44.63	55.88	19.00	13.13	9.00	-0.75	11.25	7.00	15.13	11.63	64.88	—	—	—	—

Note: Terminal box is on top of motor on 3-phase up to 10 hp. All other motors have terminal box on the side. Reference D2 dimension. Weights are based on pump with TEFC motor.

Dimensional sketches G30 (3" x 2" x 13")

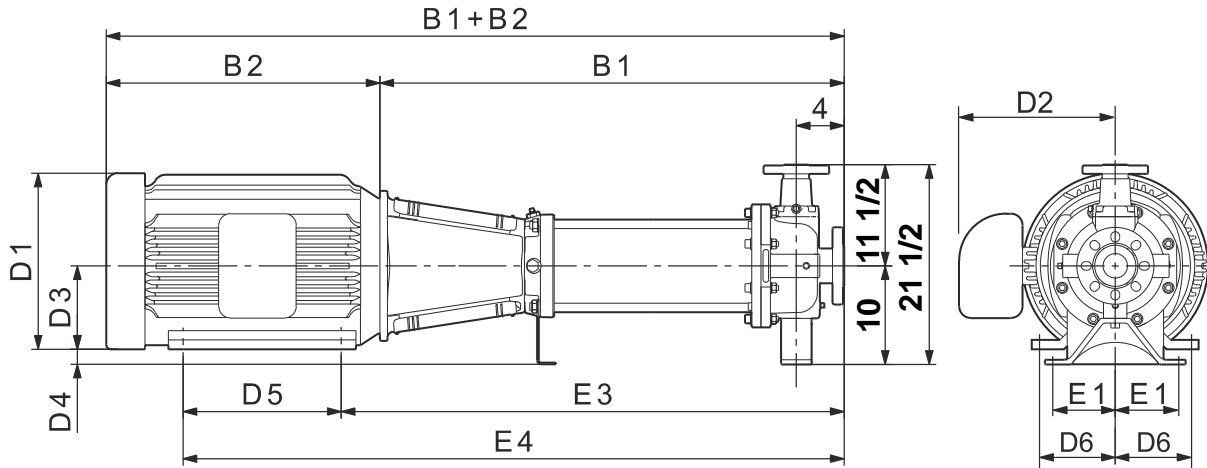

TM04 4872 0510

Dimensions and weights G30 (3" x 2" x 13")

Pump type	Power [hp]	Ph	Dimensions [inches]										Ship. weight [lbs]	Dimensions [inches]			Ship. weight [lbs]			
			TEFC											ODP				MLE		
			B1	B1+B	E1	E3	E4	D1	D2	D3	D4	D5		D6	D1	D2		B1+B	D1	D2
CR(E) 64-1-1 H	7.50	1	26.00	41.25	4.88	29.25	34.75	10.25	7.63	5.25	4.75	5.50	4.25	—	—	—	—	—	—	—
		3	26.00	41.50	4.88	29.25	34.75	8.75	5.38	5.25	4.75	5.50	4.25	—	—	—	—	8.75	7.50	41.50
CR 64-1 H	15	3	26.00	43.88	4.88	30.00	38.25	10.25	8.75	6.25	3.75	8.25	5.00	10.63	6.88	42.00	—	—	—	—
CR 64-2-2 H	15	3	29.25	47.13	4.88	33.25	41.50	10.25	8.75	6.25	3.75	8.25	5.00	10.63	6.88	45.25	—	—	—	—
CR 64-2-1 H	20	3	29.25	46.75	4.88	33.25	41.50	10.25	8.88	6.25	3.75	8.25	5.00	11.50	9.13	48.63	—	—	—	—
CR 64-2 H	25	3	29.25	50.88	4.88	33.75	43.25	13.38	12.13	7.00	3.00	9.50	5.50	11.50	9.13	49.75	—	—	—	—
CR 64-3-2 H	30	3	32.50	55.38	4.88	37.00	48.00	15.38	13.13	7.00	3.00	11.00	5.50	11.50	9.13	54.00	—	—	—	—
CR 64-3-1 H	40	3	32.50	55.38	4.88	37.00	48.00	15.38	10.50	7.00	3.00	11.00	5.50	13.25	10.00	55.50	—	—	—	—
CR 64-3 H	40	3	32.50	55.38	4.88	37.00	48.00	15.38	10.50	7.00	3.00	11.00	5.50	13.25	10.00	55.50	—	—	—	—
CR 64-4-2 H	40	3	35.75	58.63	4.88	40.25	51.25	15.38	10.50	7.00	3.00	11.00	5.50	13.25	10.00	58.75	—	—	—	—
CR 64-4-1 H	50	3	35.75	63.25	4.88	40.75	52.75	17.00	11.75	8.00	2.00	12.00	6.25	13.25	10.00	58.25	—	—	—	—
CR 64-4 H	50	3	35.75	63.25	4.88	40.75	52.75	17.00	11.75	8.00	2.00	12.00	6.25	13.25	10.00	58.25	—	—	—	—
CR 64-5-2 H	60	3	39.00	69.50	4.88	44.63	55.88	19.00	13.13	9.00	1.00	11.25	7.00	15.13	11.63	64.88	—	—	—	—

Note: Terminal box is on top of motor on 3-phase up to 10 hp. All other motors have terminal box on the side. Reference D2 dimension. Weights are based on pump with TEFC motor.

Dimensional sketches G60 (3" x 2" x 8", 3" x 2" x 10")

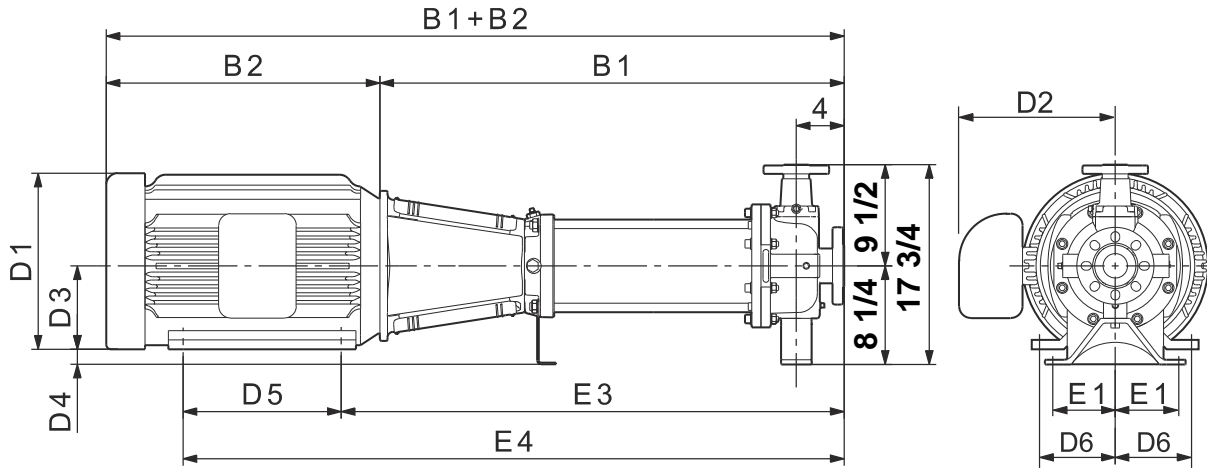

TM04 4872 0510

Dimensions and weights G60 (3" x 2" x 8", 3" x 2" x 10")

Pump type	Power [hp]	Ph	Dimensions [inches]												Ship. weight [lbs]	Dimensions [inches]			Ship. weight [lbs]			
			TEFC													ODP				MLE		
			B1	B1+B2	E1	E3	E4	D1	D2	D3	D4	D5	D6	D1		D2	B1+B2	D1		D2	B1+B2	
CR(E) 64-1-1 H	7.5	1	26.00	41.25	4.88	29.25	34.75	10.25	7.63	5.25	3.00	5.50	4.25	—	—	—	—	—	—	—	—	
		3	26.00	41.50	4.88	29.25	34.75	8.75	5.38	5.25	3.00	5.50	4.25	—	—	—	—	8.75	7.50	41.50	—	
CR 64-1 H	15	3	26.00	43.88	4.88	30.00	38.25	10.25	8.75	6.25	2.00	8.25	5.00	10.63	6.88	42.00	—	—	—	—	—	
CR 64-2-2 H	15	3	29.25	47.13	4.88	33.25	41.50	10.25	8.75	6.25	2.00	8.25	5.00	10.63	6.88	45.25	—	—	—	—	—	
CR 64-2-1 H	20	3	29.25	46.75	4.88	33.25	41.50	10.25	8.88	6.25	2.00	8.25	5.00	11.50	9.13	48.63	—	—	—	—	—	
CR(E) 64-2 H	25	3	29.25	50.88	4.88	33.75	43.25	13.38	12.13	7.00	1.25	9.50	5.50	11.50	9.13	49.75	—	—	—	—	—	
CR(E) 64-3-2 H	30	3	32.50	55.38	4.88	37.00	48.00	15.38	13.13	7.00	1.25	11.00	5.50	11.50	9.13	54.00	—	—	—	—	—	
CR 64-3-1 H	40	3	32.50	55.38	4.88	37.00	48.00	15.38	10.50	7.00	1.25	11.00	5.50	13.25	10.00	55.50	—	—	—	—	—	
CR 64-3 H	40	3	32.50	55.38	4.88	37.00	48.00	15.38	10.50	7.00	1.25	11.00	5.50	13.25	10.00	55.50	—	—	—	—	—	
CR 64-4-2 H	40	3	35.75	58.63	4.88	40.25	51.25	15.38	10.50	7.00	1.25	11.00	5.50	13.25	10.00	58.75	—	—	—	—	—	
CR 64-4-1 H	50	3	35.75	63.25	4.88	40.75	52.75	17.00	11.75	8.00	0.25	12.00	6.25	13.25	10.00	58.25	—	—	—	—	—	
CR 64-4 H	50	3	35.75	63.25	4.88	40.75	52.75	17.00	11.75	8.00	0.25	12.00	6.25	13.25	10.00	58.25	—	—	—	—	—	
CR 64-5-2 H	60	3	39.00	69.50	4.88	44.63	55.88	19.00	13.13	9.00	-0.75	11.25	7.00	15.13	11.63	64.88	—	—	—	—	—	

Note: Terminal box is on top of motor on 3-phase up to 10 hp. All other motors have terminal box on the side. Reference D2 dimension. Weights are based on pump with TEFC motor.

CR, CRE 64 H G20/G50

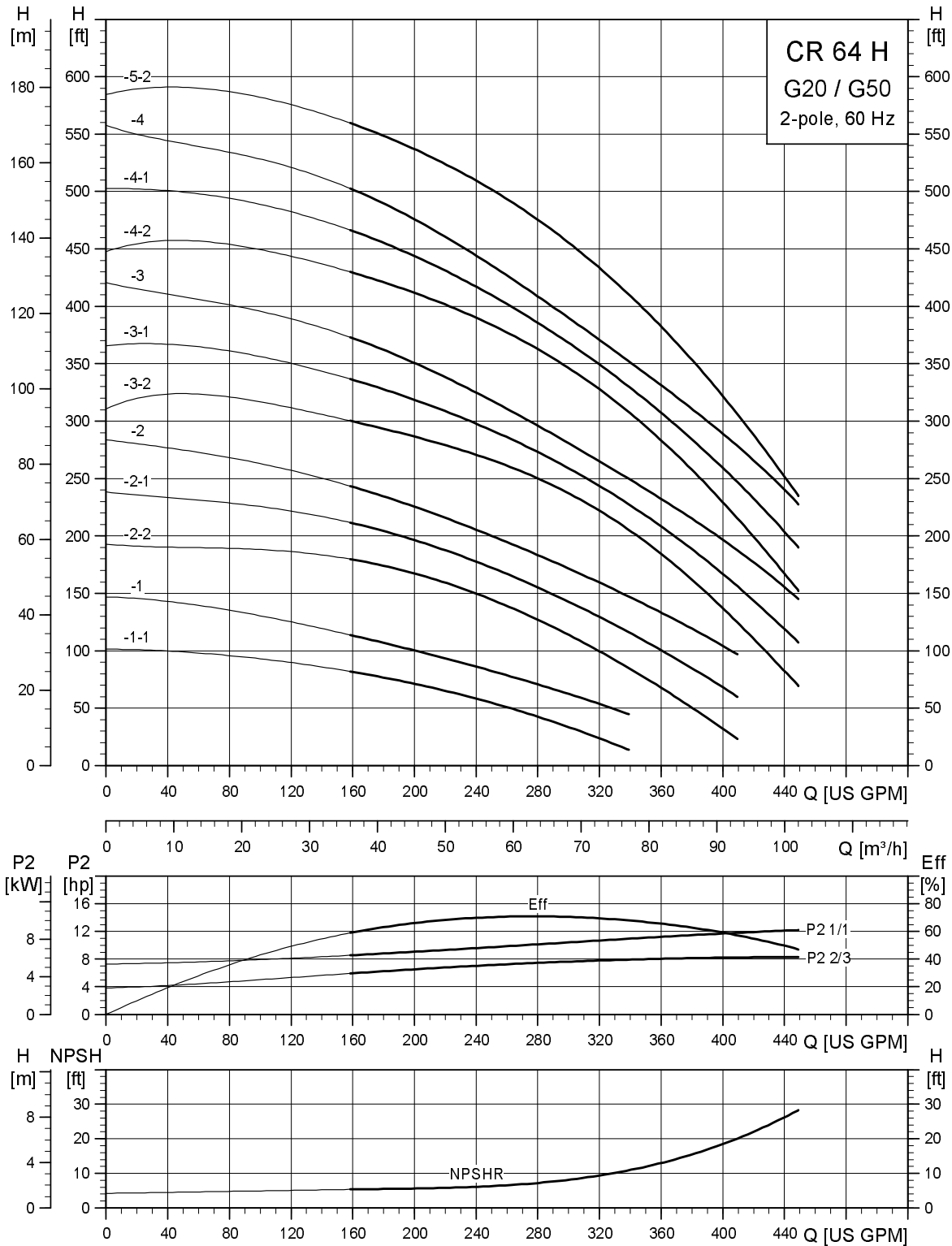

TM04 6299 0310

Dimensional sketches G20 (3" x 1.5" x 13")

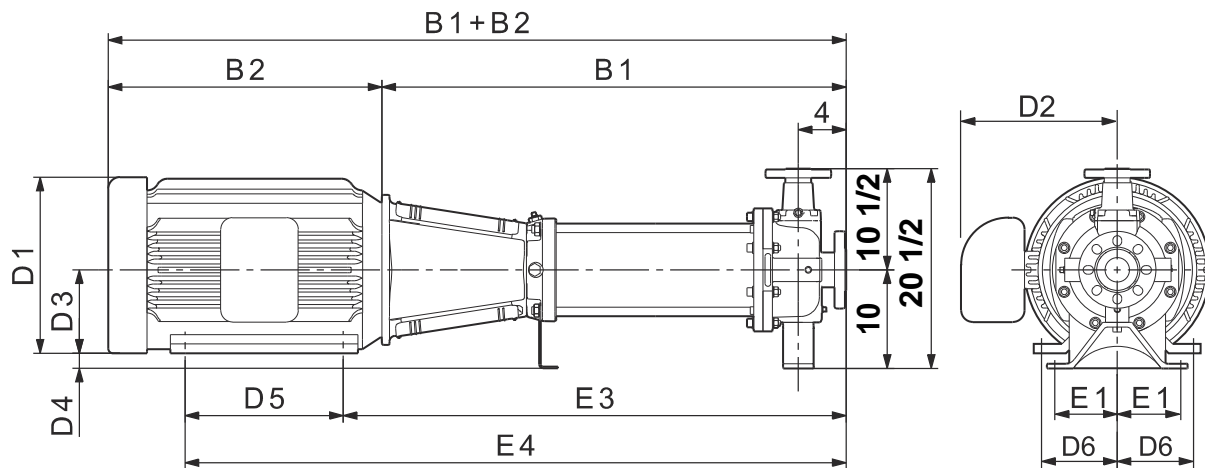

TM04 4872 0510

Dimensions and weights G20 (3" x 1.5" x 13")

Pump type	Power [hp]	Ph	Dimensions [inches]												Ship. weight [lbs]	Dimensions [inches]			Ship. weight [lbs]	
			TEFC										ODP			MLE				
			B1	B1+B2	E1	E3	E4	D1	D2	D3	D4	D5	D6	D1		D2	B1+B2	D1		D2
CR(E) 64-1-1 H	7.5	1	26.00	41.25	4.88	29.25	34.75	10.25	7.63	5.25	4.75	5.50	4.25	—	—	—	—	—	—	—
		3	26.00	41.50	4.88	29.25	34.75	8.75	5.38	5.25	4.75	5.50	4.25	—	—	—	—	8.75	7.50	41.50
CR 64-1 H	15	3	26.00	43.88	4.88	30.00	38.25	10.25	8.75	6.25	3.75	8.25	5.00	10.63	6.88	42.00	—	—	—	—
CR 64-2-2 H	15	3	29.25	47.13	4.88	33.25	41.50	10.25	8.75	6.25	3.75	8.25	5.00	10.63	6.88	45.25	—	—	—	—
CR 64-2-1 H	20	3	29.25	46.75	4.88	33.25	41.50	10.25	8.88	6.25	3.75	8.25	5.00	11.50	9.13	48.63	—	—	—	—
CR 64-2 H	25	3	29.25	50.88	4.88	33.75	43.25	13.38	12.13	7.00	3.00	9.50	5.50	11.50	9.13	49.75	—	—	—	—
CR 64-3-2 H	30	3	32.50	55.38	4.88	37.00	48.00	15.38	13.13	7.00	3.00	11.00	5.50	11.50	9.13	54.00	—	—	—	—
CR 64-3-1 H	40	3	32.50	55.38	4.88	37.00	48.00	15.38	10.50	7.00	3.00	11.00	5.50	13.25	10.00	55.50	—	—	—	—
CR 64-3 H	40	3	32.50	55.38	4.88	37.00	48.00	15.38	10.50	7.00	3.00	11.00	5.50	13.25	10.00	55.50	—	—	—	—
CR 64-4-2 H	40	3	35.75	58.63	4.88	40.25	51.25	15.38	10.50	7.00	3.00	11.00	5.50	13.25	10.00	58.75	—	—	—	—
CR 64-4-1 H	50	3	35.75	63.25	4.88	40.75	52.75	17.00	11.75	8.00	2.00	12.00	6.25	13.25	10.00	58.25	—	—	—	—
CR 64-4 H	50	3	35.75	63.25	4.88	40.75	52.75	17.00	11.75	8.00	2.00	12.00	6.25	13.25	10.00	58.25	—	—	—	—
CR 64-5-2 H	60	3	39.00	69.50	4.88	44.63	55.88	19.00	13.13	9.00	1.00	11.25	7.00	15.13	11.63	64.88	—	—	—	—

Note: Terminal box is on top of motor on 3-phase up to 10 hp. All other motors have terminal box on the side. Reference D2 dimension. Weights are based on pump with TEFC motor.

Dimensional sketches G50 (3" x 1.5" x 8", 3" x 1.5" x 10")

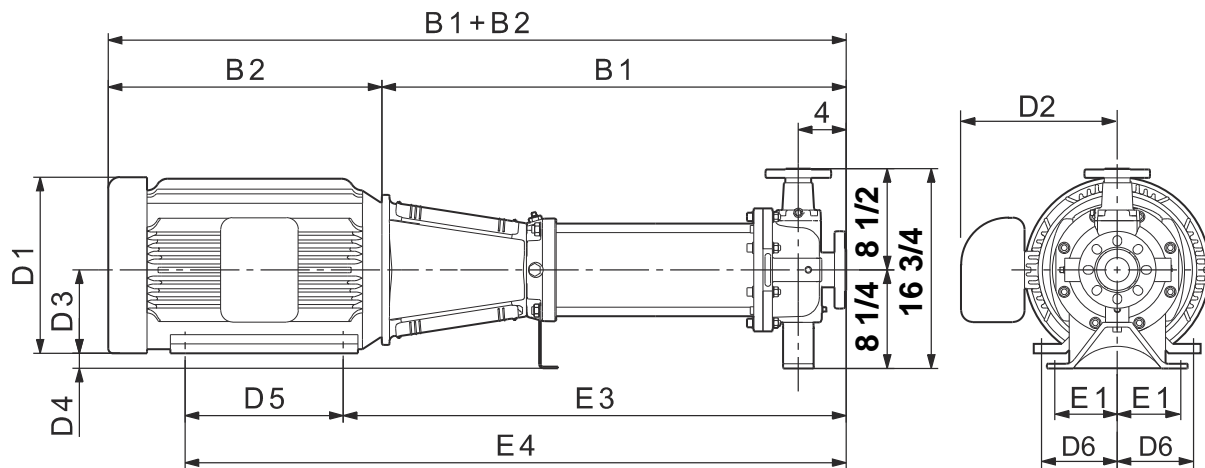

TM04 4872 0510

Dimensions and weights G50 (3" x 1.5" x 8", 3" x 1.5" x 10")

Pump type	Power [hp]	Ph	Dimensions [inches]										Ship. weight [lbs]	Dimensions [inches]			Ship. weight [lbs]			
			TEFC											ODP				MLE		
			B1	B1+B2	E1	E3	E4	D1	D2	D3	D4	D5		D6	D1	D2		B1+B2	D1	D2
CR(E) 64-1-1 H	7.5	1	26.00	41.25	4.88	29.25	34.75	10.25	7.63	5.25	3.00	5.50	4.25	—	—	—	—	—	—	—
		3	26.00	41.50	4.88	29.25	34.75	8.75	5.38	5.25	3.00	5.50	4.25	—	—	—	—	8.75	7.50	41.50
CR 64-1 H	15	3	26.00	43.88	4.88	30.00	38.25	10.25	8.75	6.25	2.00	8.25	5.00	10.63	6.88	42.00	—	—	—	—
CR 64-2-2 H	15	3	29.25	47.13	4.88	33.25	41.50	10.25	8.75	6.25	2.00	8.25	5.00	10.63	6.88	45.25	—	—	—	—
CR 64-2-1 H	20	3	29.25	46.75	4.88	33.25	41.50	10.25	8.88	6.25	2.00	8.25	5.00	11.50	9.13	48.63	—	—	—	—
CR 64-2 H	25	3	29.25	50.88	4.88	33.75	43.25	13.38	12.13	7.00	1.25	9.50	5.50	11.50	9.13	49.75	—	—	—	—
CR 64-3-2 H	30	3	32.50	55.38	4.88	37.00	48.00	15.38	13.13	7.00	1.25	11.00	5.50	11.50	9.13	54.00	—	—	—	—
CR 64-3-1 H	40	3	32.50	55.38	4.88	37.00	48.00	15.38	10.50	7.00	1.25	11.00	5.50	13.25	10.00	55.50	—	—	—	—
CR 64-3 H	40	3	32.50	55.38	4.88	37.00	48.00	15.38	10.50	7.00	1.25	11.00	5.50	13.25	10.00	55.50	—	—	—	—
CR 64-4-2 H	40	3	35.75	58.63	4.88	40.25	51.25	15.38	10.50	7.00	1.25	11.00	5.50	13.25	10.00	58.75	—	—	—	—
CR 64-4-1 H	50	3	35.75	63.25	4.88	40.75	52.75	17.00	11.75	8.00	0.25	12.00	6.25	13.25	10.00	58.25	—	—	—	—
CR 64-4 H	50	3	35.75	63.25	4.88	40.75	52.75	17.00	11.75	8.00	0.25	12.00	6.25	13.25	10.00	58.25	—	—	—	—
CR 64-5-2 H	60	3	39.00	69.50	4.88	44.63	55.88	19.00	13.13	9.00	-0.75	11.25	7.00	15.13	11.63	64.88	—	—	—	—

Note: Terminal box is on top of motor on 3-phase up to 10 hp. All other motors have terminal box on the side. Reference D2 dimension. Weights are based on pump with TEFC motor.

CR, CRE 64 H G40/G70

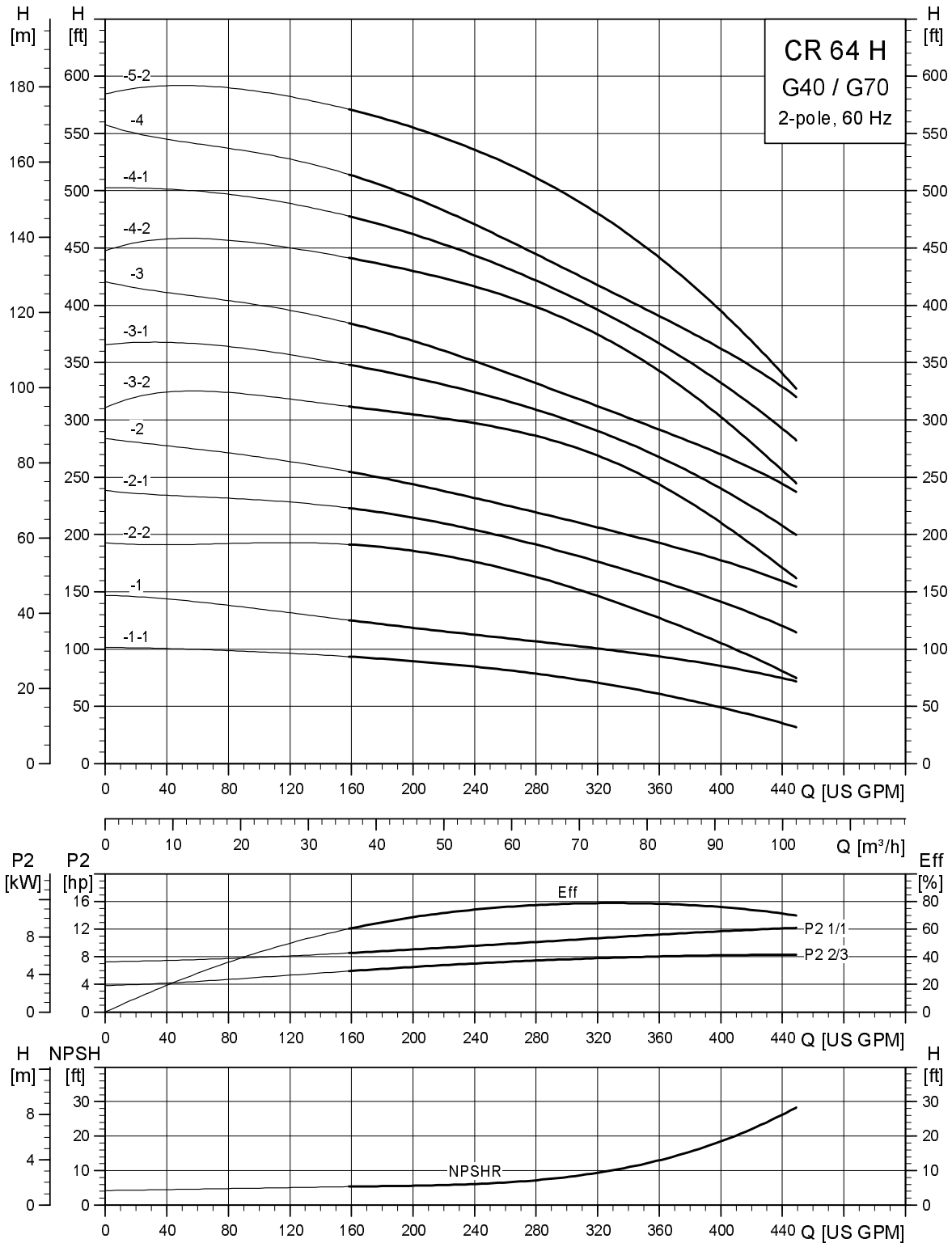

TM04 6301 0310

Dimensional sketches G70 (4" x 3" x 8", 4" x 3" x 10")

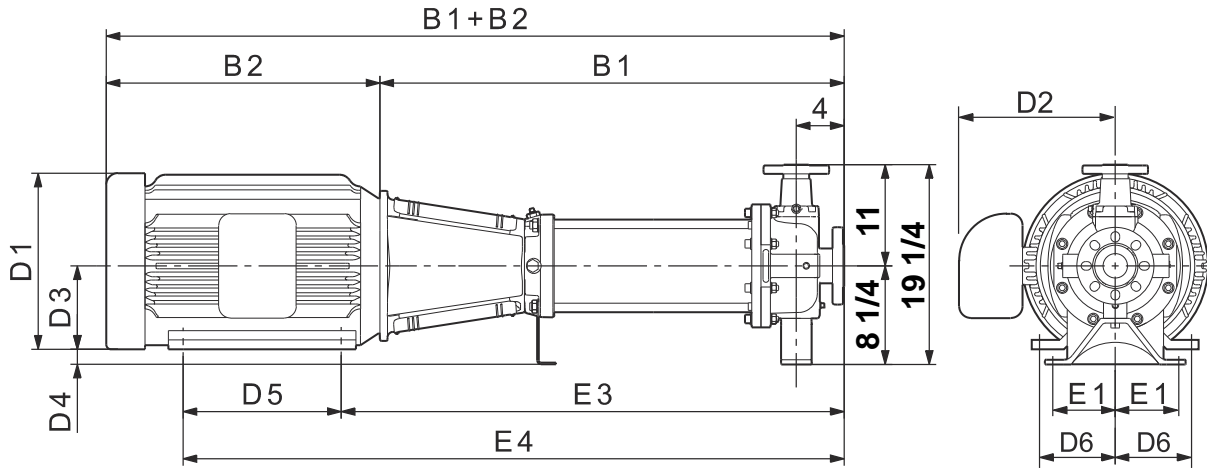

TM04 4872 0510

Dimensions and weights G70 (4" x 3" x 8", 4" x 3" x 10")

Pump type	Power [hp]	Ph	Dimensions [inches]													Ship. weight [lbs]	Dimensions [inches]			Ship. weight [lbs]	
			TEFC										ODP				MLE				
			B1	B1+B2	E1	E3	E4	D1	D2	D3	D4	D5	D6	D1	D2		B1+B2	D1	D2		B1+B2
CR(E) 64-1-1 H	7.5	1	27.13	42.38	4.88	30.38	35.88	10.25	7.63	5.25	3.00	5.50	4.25	—	—	—	—	—	—	—	—
		3	27.13	42.63	4.88	30.38	35.88	8.75	5.38	5.25	3.00	5.50	4.25	—	—	—	—	8.75	7.50	42.63	—
CR 64-1 H	15	3	27.13	45.00	4.88	31.13	39.38	10.25	8.75	6.25	2.00	8.25	5.00	10.63	6.88	43.13	—	—	—	—	—
CR 64-2-2 H	15	3	30.38	48.25	4.88	34.38	42.63	10.25	8.75	6.25	2.00	8.25	5.00	10.63	6.88	46.38	—	—	—	—	—
CR 64-2-1 H	20	3	30.38	47.88	4.88	34.38	42.63	10.25	8.88	6.25	2.00	8.25	5.00	11.50	9.13	49.75	—	—	—	—	—
CR 64-2 H	25	3	30.38	52.00	4.88	34.88	44.38	13.38	12.13	7.00	1.25	9.50	5.50	11.50	9.13	50.88	—	—	—	—	—
CR 64-3-2 H	30	3	33.63	56.50	4.88	38.13	49.13	15.38	13.13	7.00	1.25	11.00	5.50	11.50	9.13	55.13	—	—	—	—	—
CR 64-3-1 H	40	3	33.63	56.50	4.88	38.13	49.13	15.38	10.50	7.00	1.25	11.00	5.50	13.25	10.00	56.63	—	—	—	—	—
CR 64-3 H	40	3	33.63	56.50	4.88	38.13	49.13	15.38	10.50	7.00	1.25	11.00	5.50	13.25	10.00	56.63	—	—	—	—	—
CR 64-4-2 H	40	3	36.88	59.75	4.88	41.38	52.38	15.38	10.50	7.00	1.25	11.00	5.50	13.25	10.00	59.88	—	—	—	—	—
CR 64-4-1 H	50	3	36.88	64.38	4.88	41.88	53.88	17.00	11.75	8.00	0.25	12.00	6.25	13.25	10.00	59.38	—	—	—	—	—
CR 64-4 H	50	3	36.88	64.38	4.88	41.88	53.88	17.00	11.75	8.00	0.25	12.00	6.25	13.25	10.00	59.38	—	—	—	—	—
CR 64-5-2 H	60	3	40.13	70.63	4.88	45.75	57.00	19.00	13.13	9.00	-0.75	11.25	7.00	15.13	11.63	66.00	—	—	—	—	—

Note: Terminal box is on top of motor on 3-phase up to 10 hp. All other motors have terminal box on the side. Reference D2 dimension. Weights are based on pump with TEFC motor.

CR 90 H G44

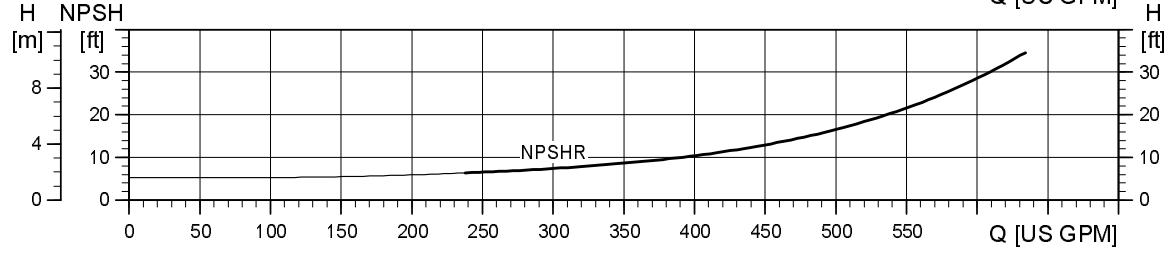
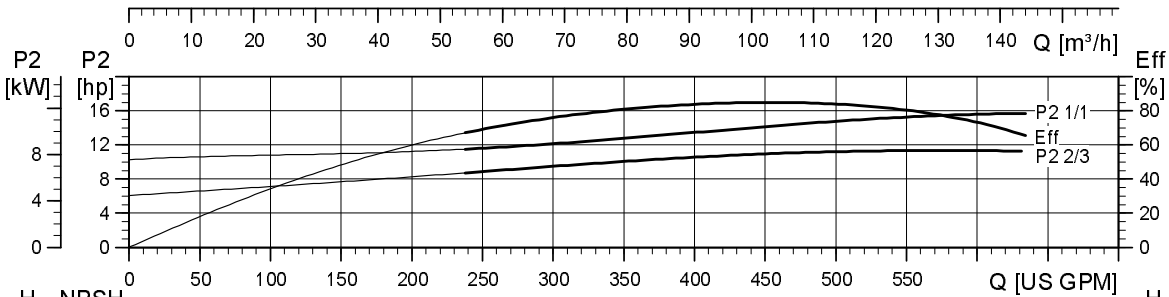
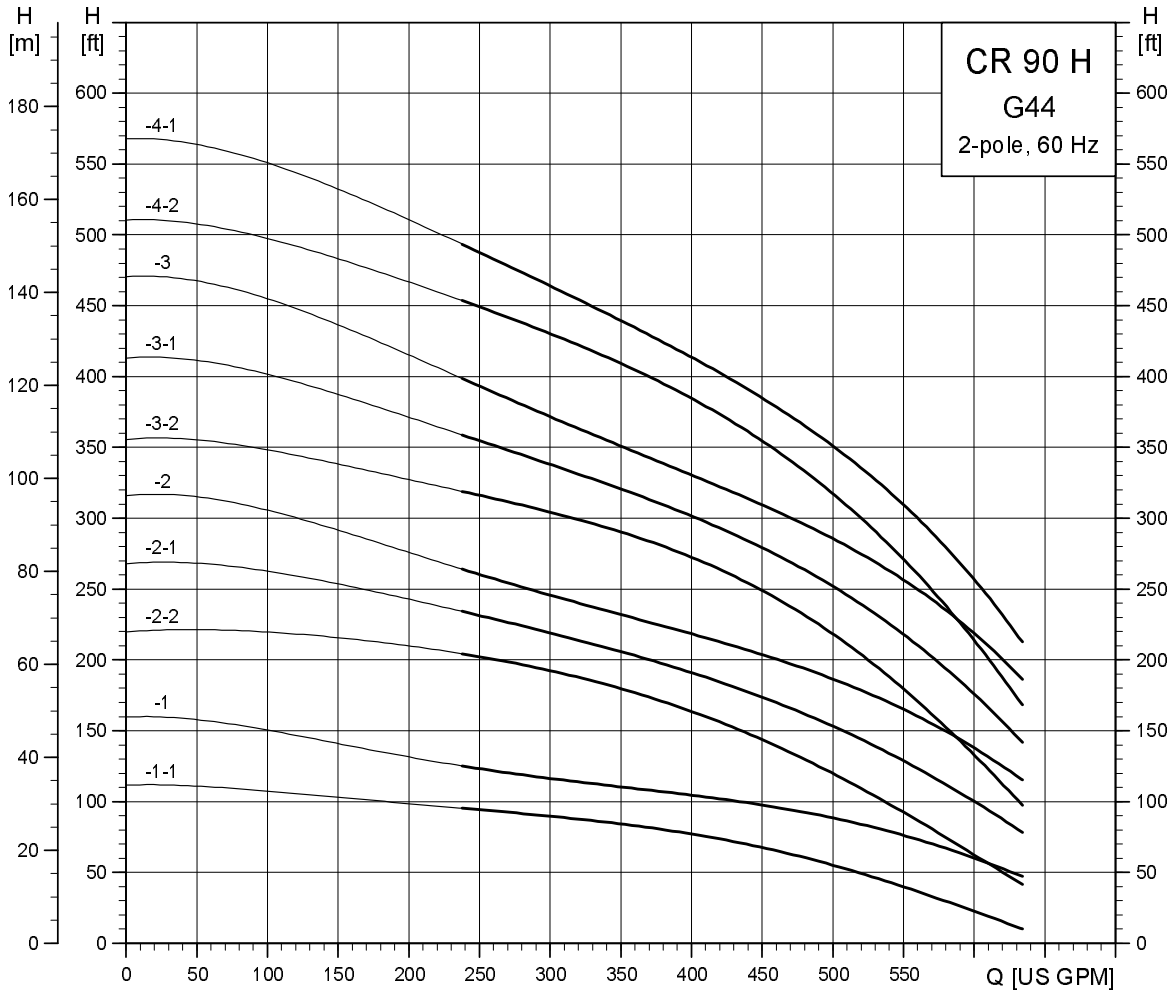

TM04 6306 0310

Dimensional sketches G44 (4" x 4")

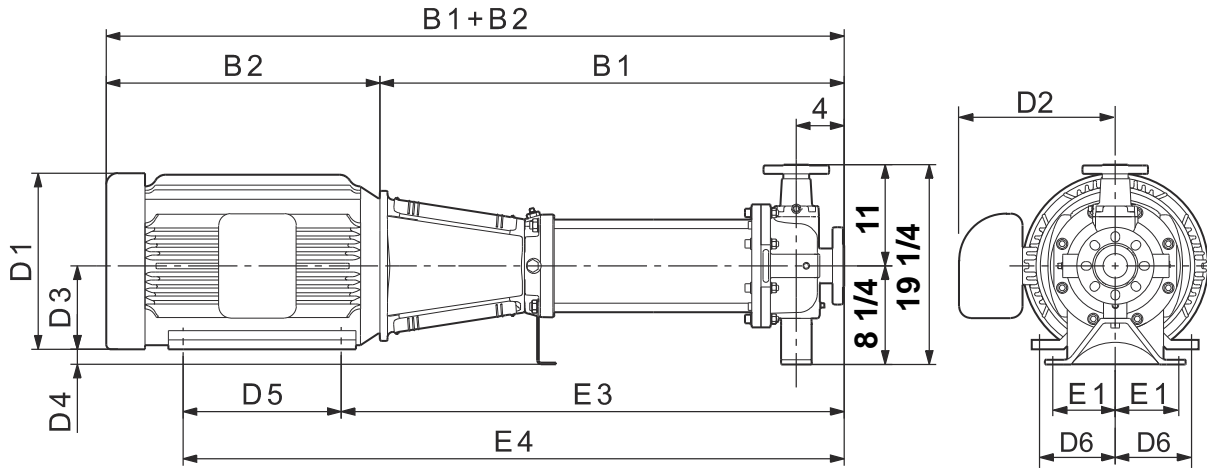

TM04 4872 0510

Dimensions and weights G44 (4" x 4")

Pump type	Power [hp]	Ph	Dimensions [inches]													Ship. weight [lbs]	Dimensions [inches]			Ship. weight [lbs]
			TEFC										ODP				MLE			
			B1	B1+B2	E1	E3	E4	D1	D2	D3	D4	D5	D6	D1	D2		B1+B2	D1	D2	
CR 90-1-1 H	15.00	3	27.50	45.38	4.88	31.50	39.75	10.25	8.75	6.25	2.00	8.25	5.00	10.63	6.88	43.50	—	—	—	—
CR 90-1 H	15.00	3	27.50	45.38	4.88	31.50	39.75	10.25	8.75	6.25	2.00	8.25	5.00	10.63	6.88	43.50	—	—	—	—
CR 90-2-2 H	25.00	3	31.13	52.75	4.88	35.63	45.13	13.38	12.13	7.00	1.25	9.50	5.50	11.50	9.13	51.63	—	—	—	—
CR 90-2-1 H	30.00	3	31.13	54.00	4.88	35.63	46.63	15.38	13.13	7.00	1.25	11.00	5.50	11.50	9.13	52.63	—	—	—	—
CR 90-2 H	40.00	3	31.13	54.00	4.88	35.63	46.63	15.38	10.50	7.00	1.25	11.00	5.50	13.25	10.00	54.13	—	—	—	—
CR 90-3-2 H	40.00	3	34.75	57.63	4.88	39.25	50.25	15.38	10.50	7.00	1.25	11.00	5.50	13.25	10.00	57.75	—	—	—	—
CR 90-3-1 H	50.00	3	34.75	62.25	4.88	39.75	51.75	17.00	11.75	8.00	0.25	12.00	6.25	13.25	10.00	57.25	—	—	—	—
CR 90-3 H	50.00	3	34.75	62.25	4.88	39.75	51.75	17.00	11.75	8.00	0.25	12.00	6.25	13.25	10.00	57.25	—	—	—	—
CR 90-4-2 H	60.00	3	38.38	68.88	4.88	44.00	55.25	19.00	13.13	9.00	-0.75	11.25	7.00	15.13	11.63	64.25	—	—	—	—
CR 90-4-1 H	60.00	3	38.38	68.88	4.88	44.00	55.25	19.00	13.13	9.00	-0.75	11.25	7.00	15.13	11.63	64.25	—	—	—	—

Note: Terminal box is on top of motor on 3-phase up to 10 hp. All other motors have terminal box on the side. Reference D2 dimension. Weights are based on pump with TEFC motor.

CR 90 H G20

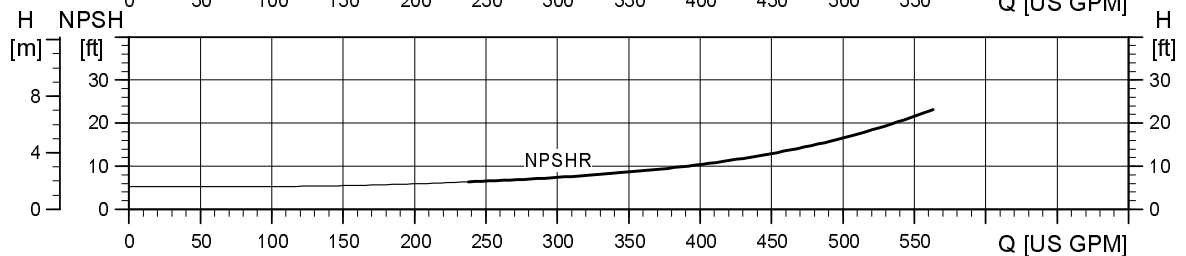
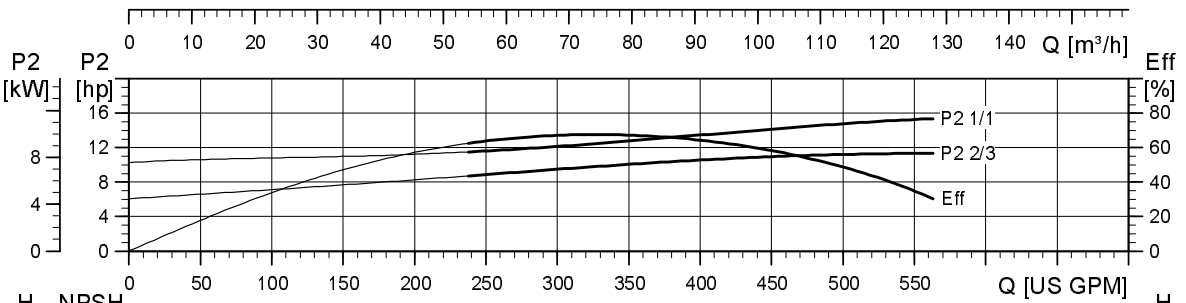
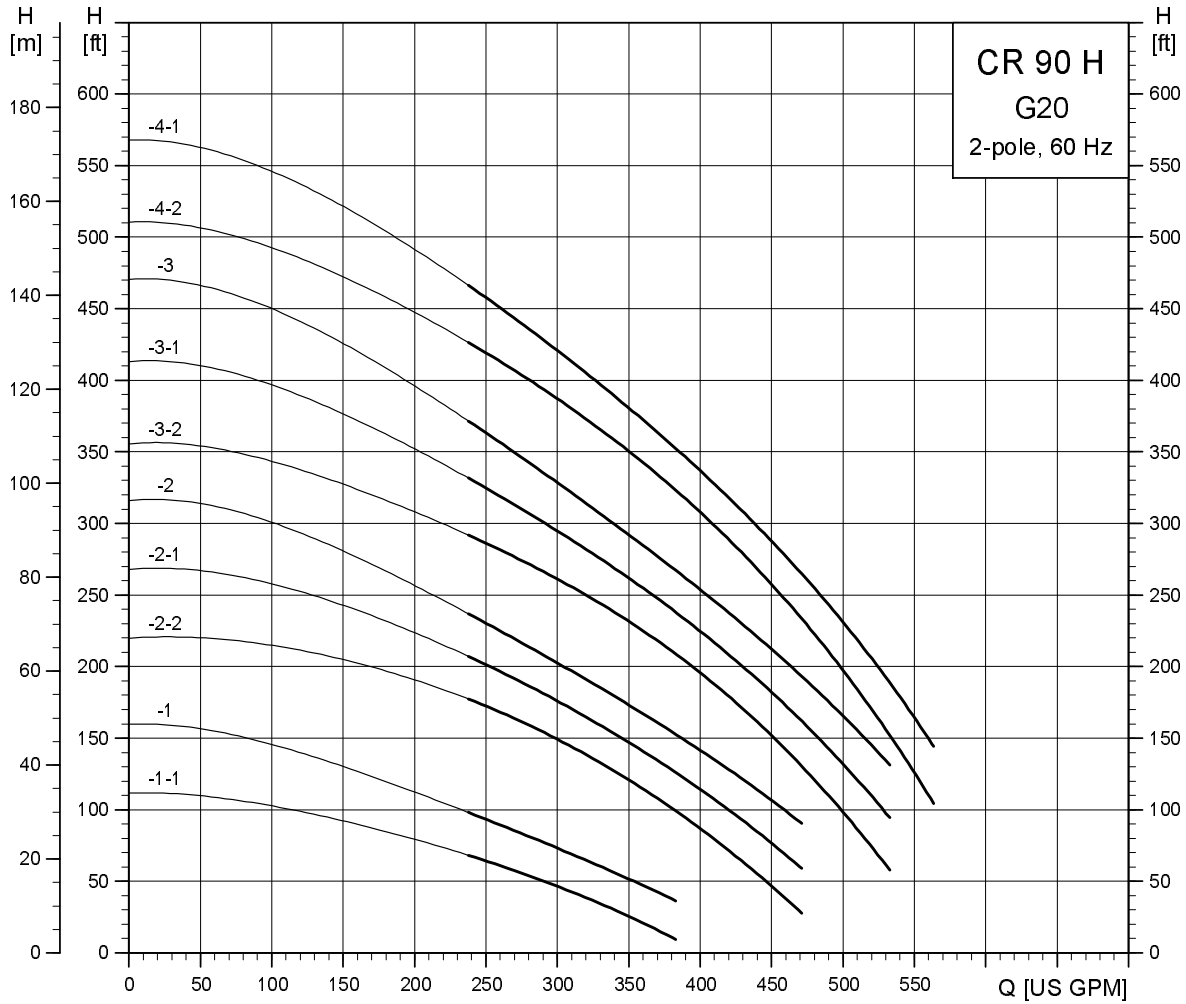

TM04 6303 0310

Dimensional sketches G20 (3" x 1.5" x 13")

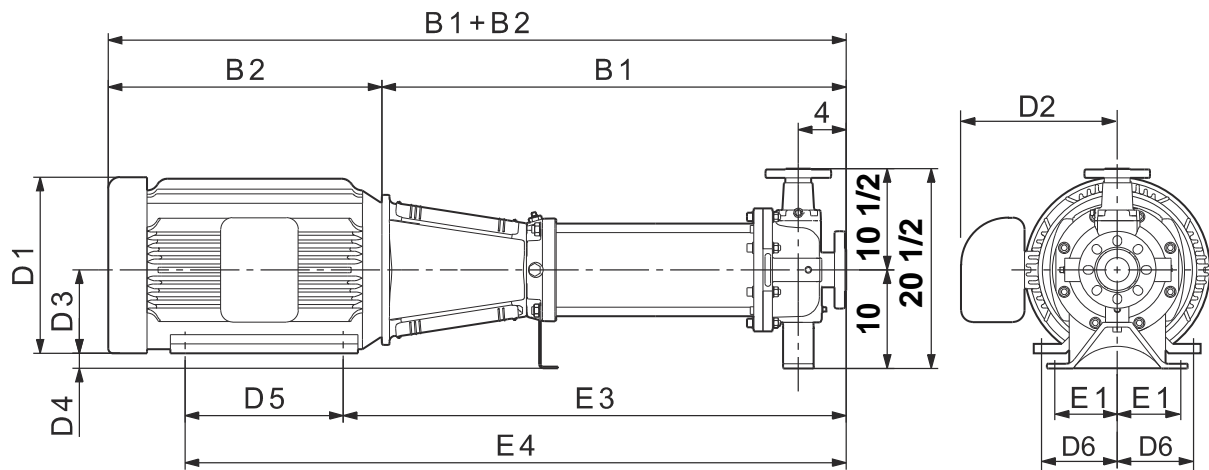

TM04 4872 0510

Dimensions and weights G20 (3" x 1.5" x 13")

Pump type	Power [hp]	Ph	Dimensions [inches]											Ship. weight [lbs]	Dimensions [inches]			Ship. weight [lbs]			
			TEFC												ODP				MLE		
			B1	B1+B	E1	E3	E4	D1	D2	D3	D4	D5	D6		D1	D2	B1+B		D1	D2	B1+B
CR 90-1-1 H	15	3	26.38	44.25	4.88	30.38	38.63	10.25	8.75	6.25	3.75	8.25	5.00	10.63	6.88	42.38	—	—	—	—	—
CR 90-1 H	15	3	26.38	44.25	4.88	30.38	38.63	10.25	8.75	6.25	3.75	8.25	5.00	10.63	6.88	42.38	—	—	—	—	—
CR 90-2-2 H	25	3	30.00	51.63	4.88	34.50	44.00	13.38	12.13	7.00	3.00	9.50	5.50	11.50	9.13	50.50	—	—	—	—	—
CR 90-2-1 H	30	3	30.00	52.88	4.88	34.50	45.50	15.38	13.13	7.00	3.00	11.00	5.50	11.50	9.13	51.50	—	—	—	—	—
CR 90-2 H	40	3	30.00	52.88	4.88	34.50	45.50	15.38	10.50	7.00	3.00	11.00	5.50	13.25	10.00	53.00	—	—	—	—	—
CR 90-3-2 H	40	3	33.63	56.50	4.88	38.13	49.13	15.38	10.50	7.00	3.00	11.00	5.50	13.25	10.00	56.63	—	—	—	—	—
CR 90-3-1 H	50	3	33.63	61.13	4.88	38.63	50.63	17.00	11.75	8.00	2.00	12.00	6.25	13.25	10.00	56.13	—	—	—	—	—
CR 90-3 H	50	3	33.63	61.13	4.88	38.63	50.63	17.00	11.75	8.00	2.00	12.00	6.25	13.25	10.00	56.13	—	—	—	—	—
CR 90-4-2 H	60	3	37.25	67.75	4.88	42.88	54.13	19.00	13.13	9.00	1.00	11.25	7.00	15.13	11.63	63.13	—	—	—	—	—
CR 90-4-1 H	60	3	37.25	67.75	4.88	42.88	54.13	19.00	13.13	9.00	1.00	11.25	7.00	15.13	11.63	63.13	—	—	—	—	—

Note: Terminal box is on top of motor on 3-phase up to 10 hp. All other motors have terminal box on the side. Reference D2 dimension. Weights are based on pump with TEFC motor.

CR 90 H G30/G60

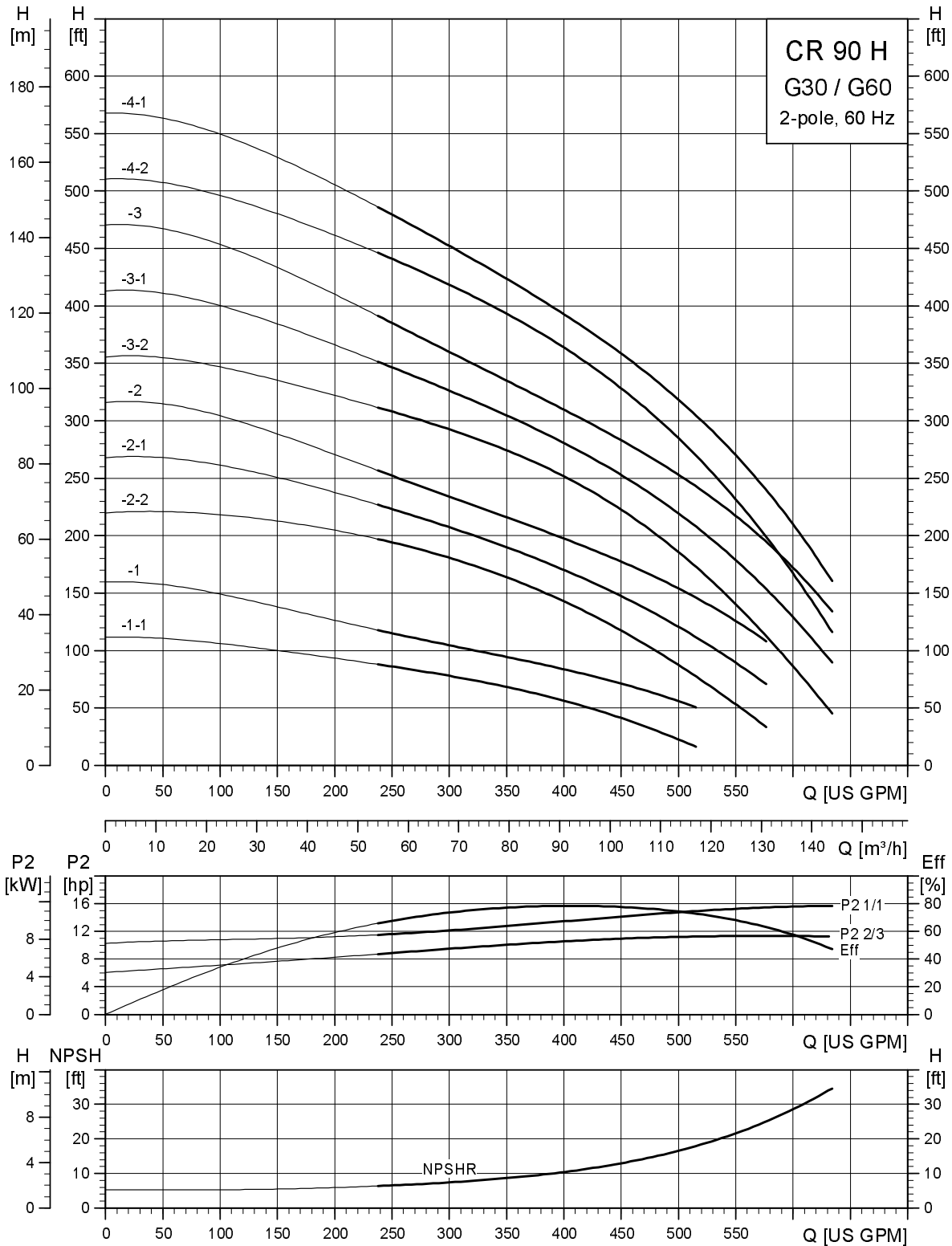

TM04 6304 0310

Dimensional sketches G30 (3" x 2" x 13")

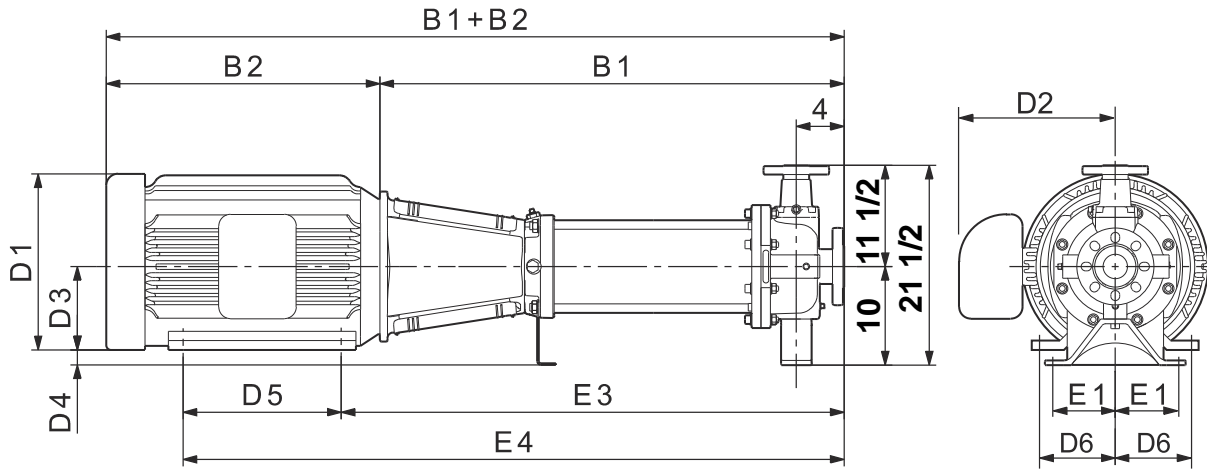

TM04 4872 0510

Dimensions and weights G30 (3" x 2" x 13")

Pump type	Power [hp]	Ph	Dimensions [inches]													Ship. weight [lbs]	Dimensions [inches]			Ship. weight [lbs]			
			TEFC														ODP				MLE		
			B1	B1+B2	E1	E3	E4	D1	D2	D3	D4	D5	D6	D1	D2		B1+B2	D1	D2		B1+B2		
CR 90-1-1 H	15	3	26.38	44.25	4.88	30.38	38.63	10.25	8.75	6.25	3.75	8.25	5.00	10.63	6.88	42.38	—	—	—	—			
CR 90-1 H	15	3	26.38	44.25	4.88	30.38	38.63	10.25	8.75	6.25	3.75	8.25	5.00	10.63	6.88	42.38	—	—	—	—			
CR 90-2-2 H	25	3	30.00	51.63	4.88	34.50	44.00	13.38	12.13	7.00	3.00	9.50	5.50	11.50	9.13	50.50	—	—	—	—			
CR 90-2-1 H	30	3	30.00	52.88	4.88	34.50	45.50	15.38	13.13	7.00	3.00	11.00	5.50	11.50	9.13	51.50	—	—	—	—			
CR 90-2 H	40	3	30.00	52.88	4.88	34.50	45.50	15.38	10.50	7.00	3.00	11.00	5.50	13.25	10.00	53.00	—	—	—	—			
CR 90-3-2 H	40	3	33.63	56.50	4.88	38.13	49.13	15.38	10.50	7.00	3.00	11.00	5.50	13.25	10.00	56.63	—	—	—	—			
CR 90-3-1 H	50	3	33.63	61.13	4.88	38.63	50.63	17.00	11.75	8.00	2.00	12.00	6.25	13.25	10.00	56.13	—	—	—	—			
CR 90-3 H	50	3	33.63	61.13	4.88	38.63	50.63	17.00	11.75	8.00	2.00	12.00	6.25	13.25	10.00	56.13	—	—	—	—			
CR 90-4-2 H	60	3	37.25	67.75	4.88	42.88	54.13	19.00	13.13	9.00	1.00	11.25	7.00	15.13	11.63	63.13	—	—	—	—			
CR 90-4-1 H	60	3	37.25	67.75	4.88	42.88	54.13	19.00	13.13	9.00	1.00	11.25	7.00	15.13	11.63	63.13	—	—	—	—			

Note: Terminal box is on top of motor on 3-phase up to 10 hp. All other motors have terminal box on the side. Reference D2 dimension. Weights are based on pump with TEFC motor.

Dimensional sketches G60 (3" x 2" x 8", 3" x 2" x 10")

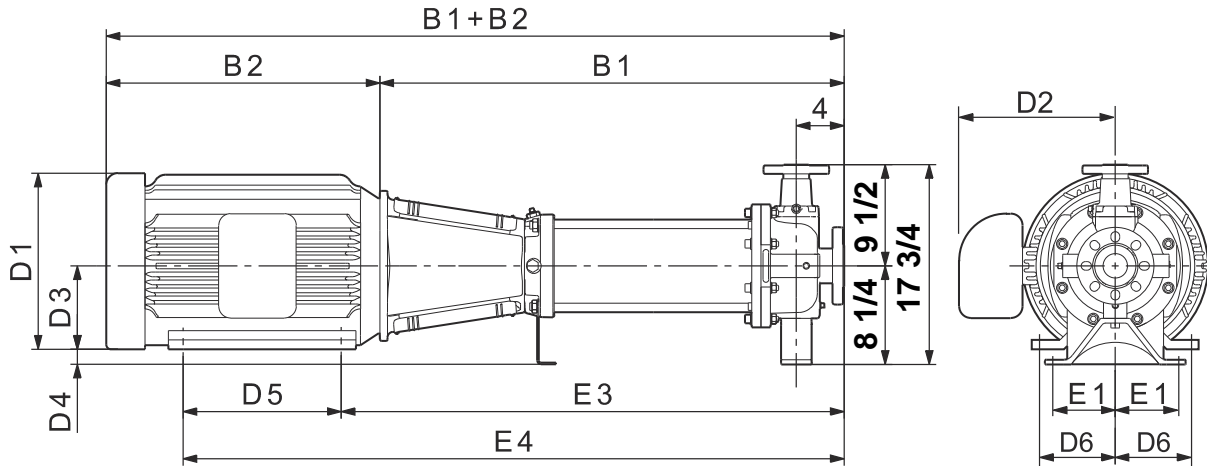

TM04 4872 0510

Dimensions and weights G60 (3" x 2" x 8", 3" x 2" x 10")

Pump type	Power [hp]	Ph	Dimensions [inches]													Ship. weight [lbs]	Dimensions [inches]			Ship. weight [lbs]			
			TEFC														ODP				MLE		
			B1	B1+B2	E1	E3	E4	D1	D2	D3	D4	D5	D6	D1	D2		B1+B2	D1	D2		B1+B2		
CR 90-1-1 H	15	3	26.38	44.25	4.88	30.38	38.63	10.25	8.75	6.25	2.00	8.25	5.00	10.63	6.88	42.38	—	—	—	—	—		
CR 90-1 H	15	3	26.38	44.25	4.88	30.38	38.63	10.25	8.75	6.25	2.00	8.25	5.00	10.63	6.88	42.38	—	—	—	—	—		
CR 90-2-2 H	25	3	30.00	51.63	4.88	34.50	44.00	13.38	12.13	7.00	1.25	9.50	5.50	11.50	9.13	50.50	—	—	—	—	—		
CR 90-2-1 H	30	3	30.00	52.88	4.88	34.50	45.50	15.38	13.13	7.00	1.25	11.00	5.50	11.50	9.13	51.50	—	—	—	—	—		
CR 90-2 H	40	3	30.00	52.88	4.88	34.50	45.50	15.38	10.50	7.00	1.25	11.00	5.50	13.25	10.00	53.00	—	—	—	—	—		
CR 90-3-2 H	40	3	33.63	56.50	4.88	38.13	49.13	15.38	10.50	7.00	1.25	11.00	5.50	13.25	10.00	56.63	—	—	—	—	—		
CR 90-3-1 H	50	3	33.63	61.13	4.88	38.63	50.63	17.00	11.75	8.00	0.25	12.00	6.25	13.25	10.00	56.13	—	—	—	—	—		
CR 90-3 H	50	3	33.63	61.13	4.88	38.63	50.63	17.00	11.75	8.00	0.25	12.00	6.25	13.25	10.00	56.13	—	—	—	—	—		
CR 90-4-2 H	60	3	37.25	67.75	4.88	42.88	54.13	19.00	13.13	9.00	-0.75	11.25	7.00	15.13	11.63	63.13	—	—	—	—	—		
CR 90-4-1 H	60	3	37.25	67.75	4.88	42.88	54.13	19.00	13.13	9.00	-0.75	11.25	7.00	15.13	11.63	63.13	—	—	—	—	—		

Note: Terminal box is on top of motor on 3-phase up to 10 hp. All other motors have terminal box on the side. Reference D2 dimension. Weights are based on pump with TEFC motor.

CR 90 H G40/G70

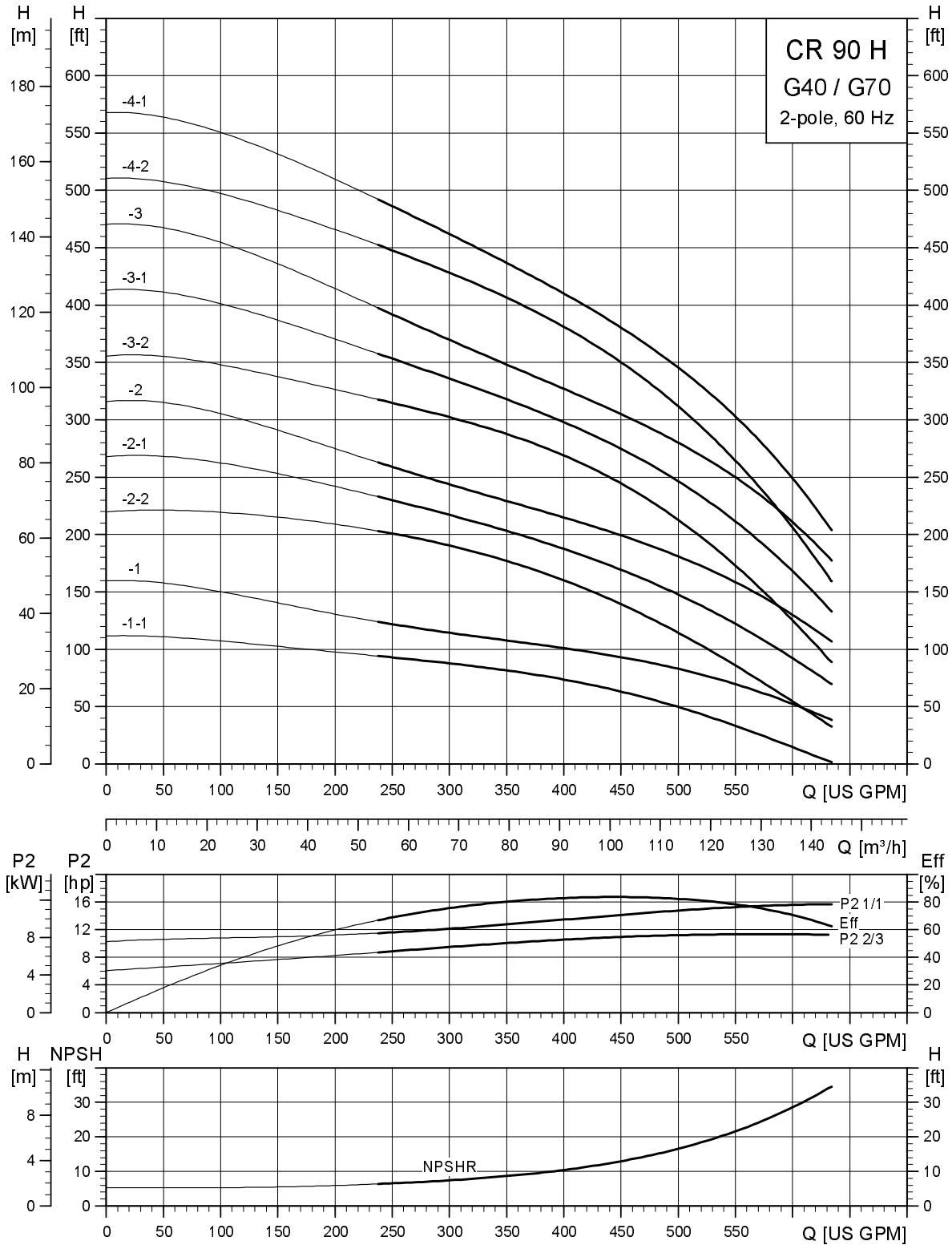

TM04 6305 0310

Dimensional sketches G40 (4" x 3" x 10", 4" x 3" x 13")

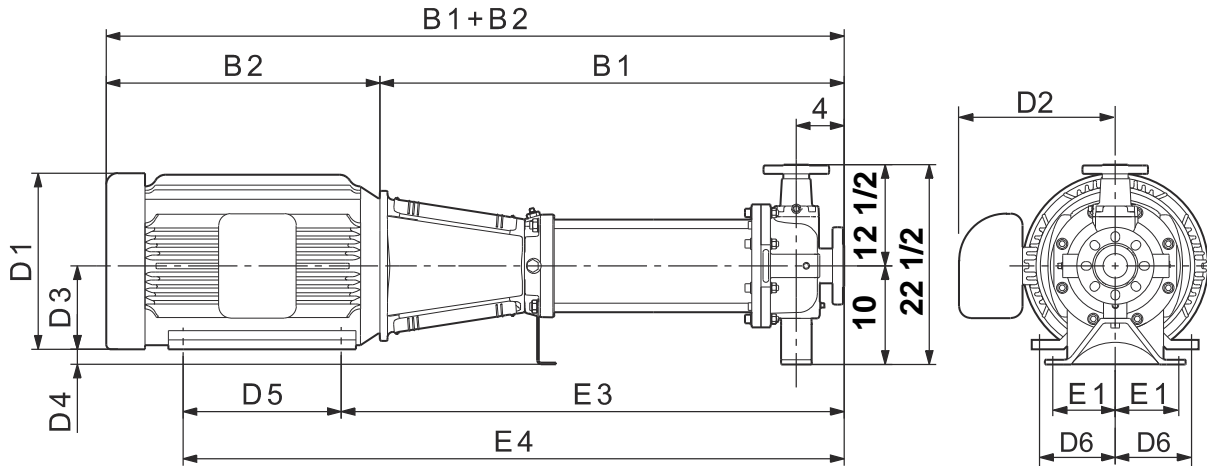

TM04 4872 0510

Dimensions and weights G40 (4" x 3" x 10", 4" x 3" x 13")

Pump type	Power [hp]	Ph	Dimensions [inches]											Ship. weight [lbs]	Dimensions [inches]			Ship. weight [lbs]			
			TEFC												ODP				MLE		
			B1	B1+B2	E1	E3	E4	D1	D2	D3	D4	D5	D6		D1	D2	B1+B2		D1	D2	B1+B2
CR 90-1-1 H	15	3	27.50	45.38	4.88	31.50	39.75	10.25	8.75	6.25	3.75	8.25	5.00	10.63	6.88	43.50	—	—	—	—	—
CR 90-1 H	15	3	27.50	45.38	4.88	31.50	39.75	10.25	8.75	6.25	3.75	8.25	5.00	10.63	6.88	43.50	—	—	—	—	—
CR 90-2-2 H	25	3	31.13	52.75	4.88	35.63	45.13	13.38	12.13	7.00	3.00	9.50	5.50	11.50	9.13	51.63	—	—	—	—	—
CR 90-2-1 H	30	3	31.13	54.00	4.88	35.63	46.63	15.38	13.13	7.00	3.00	11.00	5.50	11.50	9.13	52.63	—	—	—	—	—
CR 90-2 H	40	3	31.13	54.00	4.88	35.63	46.63	15.38	10.50	7.00	3.00	11.00	5.50	13.25	10.00	54.13	—	—	—	—	—
CR 90-3-2 H	40	3	34.75	57.63	4.88	39.25	50.25	15.38	10.50	7.00	3.00	11.00	5.50	13.25	10.00	57.75	—	—	—	—	—
CR 90-3-1 H	50	3	34.75	62.25	4.88	39.75	51.75	17.00	11.75	8.00	2.00	12.00	6.25	13.25	10.00	57.25	—	—	—	—	—
CR 90-3 H	50	3	34.75	62.25	4.88	39.75	51.75	17.00	11.75	8.00	2.00	12.00	6.25	13.25	10.00	57.25	—	—	—	—	—
CR 90-4-2 H	60	3	38.38	68.88	4.88	44.00	55.25	19.00	13.13	9.00	1.00	11.25	7.00	15.13	11.63	64.25	—	—	—	—	—
CR 90-4-1 H	60	3	38.38	68.88	4.88	44.00	55.25	19.00	13.13	9.00	1.00	11.25	7.00	15.13	11.63	64.25	—	—	—	—	—

Note: Terminal box is on top of motor on 3-phase up to 10 hp. All other motors have terminal box on the side. Reference D2 dimension. Weights are based on pump with TEFC motor.

Dimensional sketches G70 (4" x 3" x 8", 4" x 3" x 10")

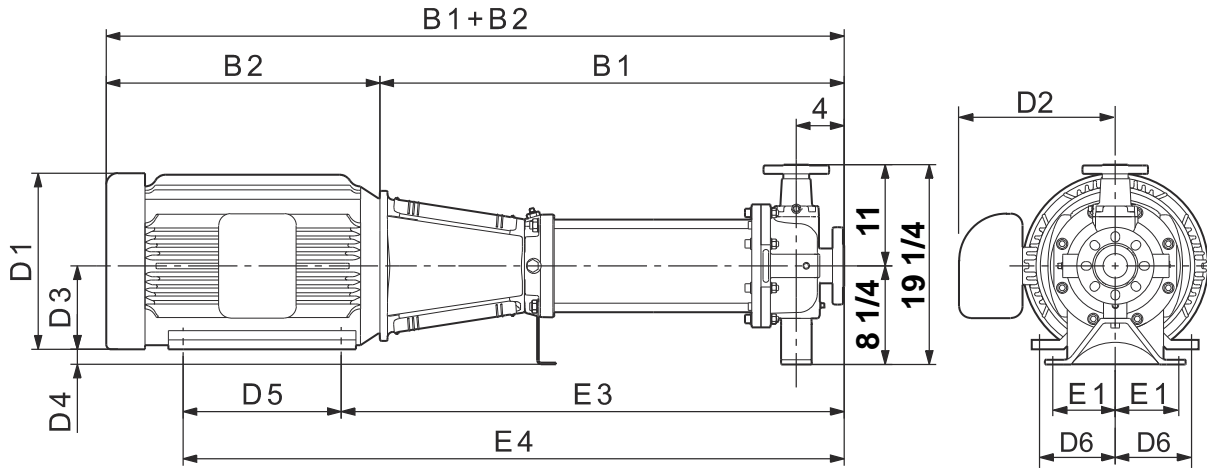

TM04 4872 0510

Dimensions and weights G70 (4" x 3" x 8", 4" x 3" x 10")

Pump type	Power [hp]	Ph	Dimensions [inches]												Ship. weight [lbs]	Dimensions [inches]			Ship. weight [lbs]			
			TEFC													ODP				MLE		
			B1	B1+B2	E1	E3	E4	D1	D2	D3	D4	D5	D6	D1		D2	B1+B2	D1		D2	B1+B2	
CR 90-1-1 H	15	3	27.50	45.38	4.88	31.50	39.75	10.25	8.75	6.25	2.00	8.25	5.00	10.63	6.88	43.50	—	—	—	—	—	
CR 90-1 H	15	3	27.50	45.38	4.88	31.50	39.75	10.25	8.75	6.25	2.00	8.25	5.00	10.63	6.88	43.50	—	—	—	—	—	
CR 90-2-2 H	25	3	31.13	52.75	4.88	35.63	45.13	13.38	12.13	7.00	1.25	9.50	5.50	11.50	9.13	51.63	—	—	—	—	—	
CR 90-2-1 H	30	3	31.13	54.00	4.88	35.63	46.63	15.38	13.13	7.00	1.25	11.00	5.50	11.50	9.13	52.63	—	—	—	—	—	
CR 90-2 H	40	3	31.13	54.00	4.88	35.63	46.63	15.38	10.50	7.00	1.25	11.00	5.50	13.25	10.00	54.13	—	—	—	—	—	
CR 90-3-2 H	40	3	34.75	57.63	4.88	39.25	50.25	15.38	10.50	7.00	1.25	11.00	5.50	13.25	10.00	57.75	—	—	—	—	—	
CR 90-3-1 H	50	3	34.75	62.25	4.88	39.75	51.75	17.00	11.75	8.00	0.25	12.00	6.25	13.25	10.00	57.25	—	—	—	—	—	
CR 90-3 H	50	3	34.75	62.25	4.88	39.75	51.75	17.00	11.75	8.00	0.25	12.00	6.25	13.25	10.00	57.25	—	—	—	—	—	
CR 90-4-2 H	60	3	38.38	68.88	4.88	44.00	55.25	19.00	13.13	9.00	-0.75	11.25	7.00	15.13	11.63	64.25	—	—	—	—	—	
CR 90-4-1 H	60	3	38.38	68.88	4.88	44.00	55.25	19.00	13.13	9.00	-0.75	11.25	7.00	15.13	11.63	64.25	—	—	—	—	—	

Note: Terminal box is on top of motor on 3-phase up to 10 hp. All other motors have terminal box on the side. Reference D2 dimension. Weights are based on pump with TEFC motor.

Motors for CR-H, CRE-H pumps

Motors used in the CR-H pump range are:

- Grundfos ML or MLE motors
- Grundfos-specified Baldor® motors

The information in the tables below applies to the following motors type and size:

Type	Phases	Motor range [hp]	Cooling
ML	3	.33 - 10	TEFC
	1	.33 - 10	TEFC
Baldor	3	15 - 60	TEFC
	3	15 - 60	ODP
	1	.5 - 1.5	TEFC
MLE	3	1 - 10	TEFC

Grundfos CR-H pumps are supplied with 2-pole, NEMA C-frame motors built or selected to our rigid specifications. All CR-H pump motors have heavy-duty bearings for maximum thrust requirements.

We do not recommend that an off-the-shelf standard Baldor motor is used on a Grundfos pump. Ideally, the best motor choice would be the Grundfos-specified motor.

Other motor types are available (i.e. explosion proof, Mill and Chem Duty, high efficiency, etc.); consult your local Grundfos company for more information.

Pumps supplied by Grundfos Canada are normally supplied with motors from other manufacturers. The 575 V motors meet EPC/NRC efficiency standards. Dimensions and data will vary; contact your local Grundfos company for more information.

All values are subject to change without notice.

Grundfos ML motor



GR 7845

Baldor motor



TM04 6540 0510

Grundfos MLE motor



GR 8972_P

TEFC motors (totally enclosed fan cooled, constant speed)

Product number	Power [hp]	Phases	Frame size	SF	Supply voltage [V]	Eff. [%]	Efficiency rating	Temp. class	KVA	FLA	SFA	LRA	Motor
84Z04526	0.33	1	56C	1.35	115/230	55	Not defined	B	K	6/3	7.6/3.8	28/14	Baldor
97567717	0.33	3	56C	1.35	208-230/460	78.5	Not defined	F	A	1.12-1.1/0.55	1.5-1.45/0.75	7.1-7.7/3.9	ML
84Z04527	0.5	1	56C	1.6	115/208-230	62	Not defined	B	K	7.4/3.7	9.8/4.9	39/21.6-19.5	Baldor
97568081	0.5	3	56C	1.25	208-230/460	78.5	Not defined	F	K	1.64-1.55/0.78	2.0-1.9/0.95	9.7-10.1/5.1	ML
84Z04528	0.75	1	56C	1.25	115/230	66	Not defined	B	K	9.6/4.8	11.4/6	56/31-28	Baldor
97678090	0.75	3	56C	1.25	208-230/460	80	Not defined	F	J	2.4-2.3/1.2	2.9-2.75/1.4	14.2-15.0/7.8	ML
84Z04529	1	1	56C	1.25	115/230	66	Not defined	B	K	12/6	14.4/7.2	77/38.5	Baldor
97568102	1	3	56C	1.25	208-230/460	80	NEMA Premium	F	K	3.25-3.35/1.68	4.0-3.9/1.95	19.2-21.8/11.0	ML
84Z04530	1.5	1	56C	1.3	115/208-230	71	Not defined	B	K	17/9.5-8.6	20.4/11.3-10.2	106/58.6-53	Baldor
97568103	1.5	3	56C	1.15	208-230/460	84	NEMA Premium	F	L	4.7-4.6/2.3	5.2-5.1/2.55	33.9-36.8/18.4	ML
84Z04531	2	1	56C	1.15	115/208-230	74	Not defined	B	K	23/12.7-11.5	25.4/12.7-12.7	156/78	Baldor
97568104	2	3	56C	1.15	208-230/460	85.5	NEMA Premium	F	M	5.7-5.4/2.7	6.55-6.1/3.05	46.2-48.6/24.3	ML
84Z04532	3	1	182TC	1.15	115/208-230	75	Not defined	F	H	29/16-14.5	31.8/18-15.9	172/95-86	Baldor
97568105	3	3	182TC	1.15	208-230/460	86.5	NEMA Premium	F	M	8.4-7.7/3.9	9.5-8.6/4.3	79.0-80.1/40.6	ML
84Z04533	5	1	213TC	1.15	230	80	Not defined	F	J	24-22	27-25	188-170	Baldor
97568106	5	3	182TC	1.15	208-230/460	88.5	NEMA Premium	F	M	13.8-13.0/6.5	15.6-14.6/7.3	124.2-128.7/64.4	ML
84Z04534	7.5	1	213TC	1.15	208-230	82	Not defined	F	F	33.8-31	35.5-33.8	244-220	Baldor
97568109	7.5	3	213TC	1.15	208-230/460	90	NEMA Premium	F	N	20.4-19.4/9.7	23-21.5/10.8	191.8-201.8/100.9	ML
84Z04535	10	1	213TC	1.15	230	85.5	Not defined	F	F	40	46	284	Baldor
97568110	10	3	213TC	1.15	208-230/460	90.2	NEMA Premium	F	M	26.5-25.5/12.8	30.5-28.5/14.5	238.5-252.5/126.8	ML
84Z04354	15	3	254TCZ	1.15	208-230/460	90.2	Energy efficient	F	K	37.5-34/17	42.5-39/19.5	336-304/152	Baldor
84Z04355	20	3	254TCZ	1.15	230/460	90.2	Energy efficient	F	K	47-46/23	53-52/26	456-412/206	Baldor
84Z04356	25	3	284TSCZ	1.15	230/460	91	Energy efficient	F	J	56/28	64/32	502-454/227	Baldor
84Z04357	30	3	286TSC	1.15	230/460	91	Energy efficient	F	G	70/35	78/39	495-448/224	Baldor
84Z04358	40	3	286TSCZ	1.15	230/460	91.7	Energy efficient	F	H	90/45	104/52	728-658/329	Baldor
84Z04359	50	3	326TSCZ	1.15	230/460	93	Energy efficient	F	F	110/55	128/64	810/405	Baldor
84Z04360	60	3	364TSCZ	1.15	230/460	93	Energy efficient	F	G	134/67	154/77	950/475	Baldor

It is recommended that you verify all electrical data for motors on the motor nameplate.

ODP Motors (open drip proof, constant speed)													
Product number	Power [hp]	Phases	Frame size	SF	Supply voltage [V]	Eff. [%]	Efficiency rating	Temp. class	KVA	FLA	SFA	LRA	Motor
84Z04540	15	3	254TCZ	1.15	208-230/460	91	Energy efficient	B	J	41-38/19	47-44/21	301-272/136	Baldor
84Z04541	20	3	254TCZ	1.15	208-230/460	90.2	Energy efficient	B	G	48/24	55/27.5	306/153	Baldor
84Z04542	25	3	284TSCZ	1.15	230/460	91	Energy efficient	B	G	59/29.5	67/33.5	374/187	Baldor
84Z04566	30	3	286TSC	1.15	230/460	91	Energy efficient	F	H	70/35	80/40	480/240	Baldor
84Z04567	40	3	286TSCZ	1.15	230/460	91.7	Energy efficient	B	F	94/97	108/111	542/271	Baldor
84Z04568	50	3	326TSCZ	1.15	230/460	91.7	Energy efficient	B	F	94/97	108/111	542/271	Baldor
84Z04569	60	3	364TSCZ	1.15	230/460	91.7	Energy efficient	B	F	94/97	108/111	542/271	Baldor

MLE Motors (integrated variable frequency drive)										
Product number	Power [hp]	Phases	Frame size	SF	Supply voltage [V]	Efficiency [%]	Insulation class	Full load current [A]	Service factor current [A]	
97666979	1/2	1	56C	1	208-230	71	F	2.8	-	
97667004	3/4	1	56C	1	208-230	74	F	3.9	-	
97667012	1	1	56C	1	208-230	76	F	5.2	-	
97667024		3	56C	1.25	460-480	70	F	1.7	2.1	
97667017	1 1/2	1	56C	1	208-230	77	F	7.5	-	
97667018		3	56C	1	208-230	77	F	4.2	-	
97667025		3	56C	1.15	460-480	80	F	2.15	2.5	
97667019	2	3	56C	1	208-230	78.3	F	5.6	-	
97667026		3	56C	1.15	460-480	82	F	2.7	3.1	
97667020	3	3	182TC	1	208-230	79.5	F	8.1	-	
97667027		3	182TC	1.15	460-480	84	F	3.7	4.3	
97667022	5	3	182TSC	1	208-230	79.7	F	13.4	-	
97667028		3	184TC	1.15	460-480	85	F	6.1	7	
97667023	7 1/2	3	182TSC	1	208-230	82.5	F	19.7	-	
97667029		3	215TC	1.15	460-480	85	F	8.9	10.3	
97667031	10	3	215TC	1.15	460-480	86	F	12	13.8	

Notes:

- 1) Motor Eff. is the total efficiency for the motor and variable frequency drive.
- 2) Some pump models run into motor service factor and cannot be run on 1.0 service factor motors. Either upsize motor or downsize pump end to keep from running into motor service factor.

Pumped liquids

We recommend CR-H pumps for thin, non-explosive liquids, not containing solid particles or fibres. The liquid must not chemically attack the pump materials. When pumping liquids with a density and/or viscosity higher than that of water, oversized motors may used, if required.

Whether a pump is suitable for a particular liquid depends on a number of factors including the chloride content, pH value, temperature and content of chemicals, oils, etc.

Please note that aggressive liquids (e.g. sea water and some acids) may attack or dissolve the protective oxide film of the stainless steel and thus cause corrosion. The CR-H, CRE-H pump type is suitable for pumping non-corrosive liquids.

List of pumped liquids

A number of typical liquids are listed on the following pages.

Other pump versions may be applicable, but those stated in the list are considered to be the best choices. The table is intended as a general guide only, and cannot replace actual testing of the pumped liquids and pump materials under specific working conditions.

The list should, however, be applied with some caution as factors such as the following may affect the chemical resistance of a specific pump version:

- concentration of the pumped liquid
- liquid temperature
- pressure.

Safety precautions must be observed when pumping dangerous liquids.

The notes in this list apply to the table on the following page.

D	Often with additives.
E	Density and/or viscosity differ from that of water. Allow for this when calculating motor output and pump performance.
F	Pump selection depends on many factors. Contact Grundfos.
H	Risk of crystallization/precipitation in shaft seal
1	The pumped liquid is highly flammable.
2	The pumped liquid is combustible.
3	Insoluble in water.
4	Low self-ignition point.

Pumped liquids

CR-H, CRE-H

Pumped liquid	Note	Liquid concentration, liquid temperature	CR-H (shaft seal materials)	
			1s, 1, 3, 5, 10, 15, 20	32, 45, 64, 90
Alkaline degreasing agent	D, F		HQQE	KUHE
Ammonium hydroxide NH ₄ OH		20 %, 104 °F (40 °C)	HQQE	KUBE
Aviation fuel	1, 3, 4, F	100 %, 68 °F (20 °C)	HQBV	KUBV
Boiler water		<248 °F (120 °C)	HQQE	KUBE
	F	248 °F - 356 °F (120 °C - 180 °C)	-	-
Calcareous water		< 194 °F (90 °C)	HQQE	KUHE
Calcium acetate (as coolant with inhibitor) Ca(CH ₃ COO) ₂	D, E	30 %, 122 °F (50 °C)	HQQE	KUHE
Calcium hydroxide Ca(OH) ₂	E	Saturated solution, 122 °F (50 °C)	HQQE	KUHE
Condensate		< 194 °F (90 °C)	HQQE	KUHE
Corn oil	D, E, 3	100 %, 176 °F (80 °C)	HQQV	KUHV
Diesel oil	2, 3, 4, F	100 %, 68 °F (20 °C)	HQBV	KUBV
Domestic hot water (potable water)		< 248 °F (120 °C)	HQQE	KUBE
Ethanol (ethyl alcohol) C ₂ H ₅ OH	1, F	100 %, 68 °F (20 °C)	HQQE	KUBE
Ethylene glycol HOCH ₂ CH ₂ OH	D, E	50 %, 122 °F (50 °C)	HQQE	KUBE
Glycerine (glycerol) OHCH ₂ CH(OH)CH ₂ OH	D, E	50 %, 122 °F (50 °C)	HQQE	KUHE
Hydraulic oil (mineral)	E, 2, 3	100 %, 212 °F (100 °C)	HQQV	KUBV
Hydraulic oil (synthetic)	E, 2, 3	100 %, 212 °F (100 °C)	HQQV	KUBV
Isopropyl alcohol CH ₃ CHOHCH ₃	1, F	100 %, 68 °F (20 °C)	HQQE	KUBE
Linoleic acid C ₁₇ H ₃₁ COOH	E, 3	100 %, 68 °F (20 °C)	HQQV	KUBV
Methanol (methyl alcohol) CH ₃ OH	1, F	100 %, 68 °F (20 °C)	HQQE	KUBE
Motor oil	E, 2, 3	100 %, 176 °F (80 °C)	HQQV	KUBV
Naphthalene C ₁₀ H ₈	E, H	100 %, 176 °F (80 °C)	HQQV	KUHV
Oil-containing water		< 212 °F (100 °C)	HQQV	KUBV
Olive oil	D, E, 3	100 %, 176 °F	HQQV	KUHV
Peanut oil	D, E, 3	100 %, 176 °F (80 °C)	HQQV	KUHV
Petrol/gasoline	1, 3, 4, F	100 %, 68 °F (20 °C)	HQBV	KUBV
Propanol C ₃ H ₇ OH	1, F	100 %, 68 °F (20 °C)	HQQV	KUBV
Propylene glycol CH ₃ CH(OH)CH ₂ OH	D, E	50 %, 194 °F (90 °C)	HQQE	KUUE
Potassium carbonate K ₂ CO ₃	E	20 %, 122 °F (50 °C)	HQQE	KUHE
Potassium formate (as coolant with inhibitor) KOOCH	D, E	30 %, 122 °F (50 °C)	HQQE	KUHE
Rape seed oil	D, E, 3	100 %, 176 °F (80 °C)	HQQV	KUHV
Silicone oil	E, 3	100 %	HQQV	KUBV
Sodium chloride (as coolant) NaCl	D, E	30 %, < 41 °F (5°C), pH>8	HQQE	KUHE
Sodium phosphate Na ₃ PO ₄	E, H	10 %, 140 °F (60°C)		
Soybean oil	D, E, 3	100 %, 176 °F (80 °C)	HQQV	KUHV
Swimming pool water (low chloride)		Approx. 2 ppm free chlorine (Cl ₂)	HQQE	KUBE

Grundfos CR-H baseplate

Grundfos CR-H baseplates can be selected by using the information on the following pages. Once you have selected your CR-H pump you can use the pump data to select the proper baseplate and motor mounting kit. You will need to know the flange connection code, motor frame size and the E4 pump length. Based on this information you can select your baseplate and motor mounting kit number.

You will need to make sure that your pump length will fit on the standard baseplate by comparing the E4 - 4" dimension to the maximum pump length. If it will not, you can select the long baseplate (XLBP). The XLBP baseplates are longer than ANSI B73.1 baseplates but have floor mounting holes at the standard lengths.

XLBP baseplates also have additional holes near the end as shown in the dimensional table.

Baseplate dimensional sketch - CR, CRE 1s, 1, 3, 5 H

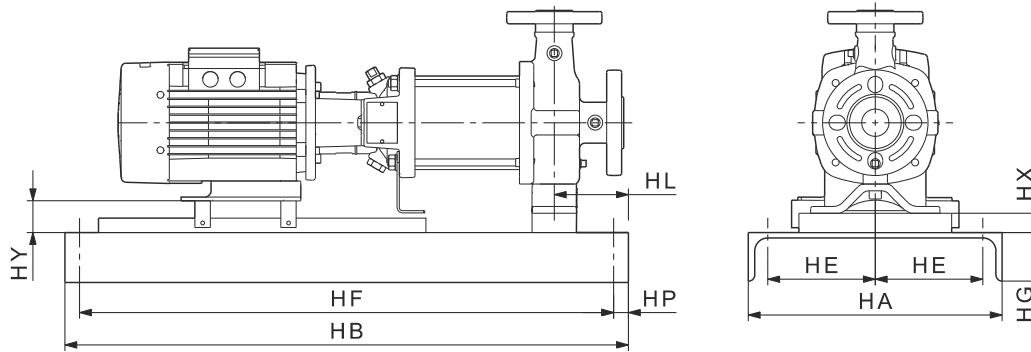

TM04 4639 1809

Baseplate dimensional sketch - CR, CRE 10, 15, 20 H

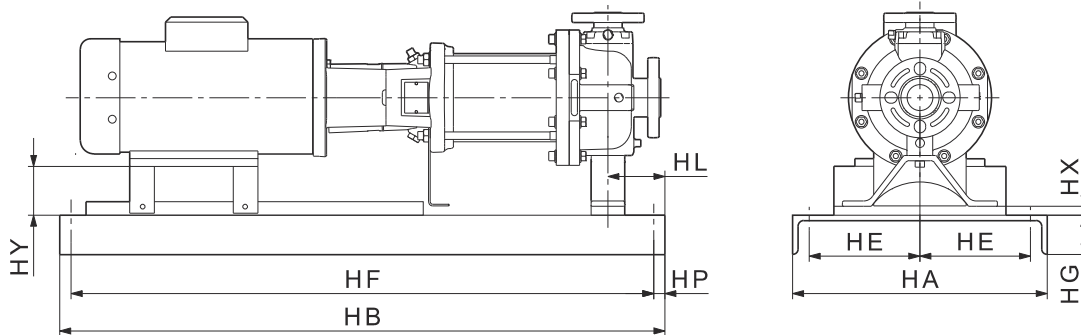

TM04 4640 1809

Baseplate dimensional sketch - CR, CRE 32, 45, 64, 90 H

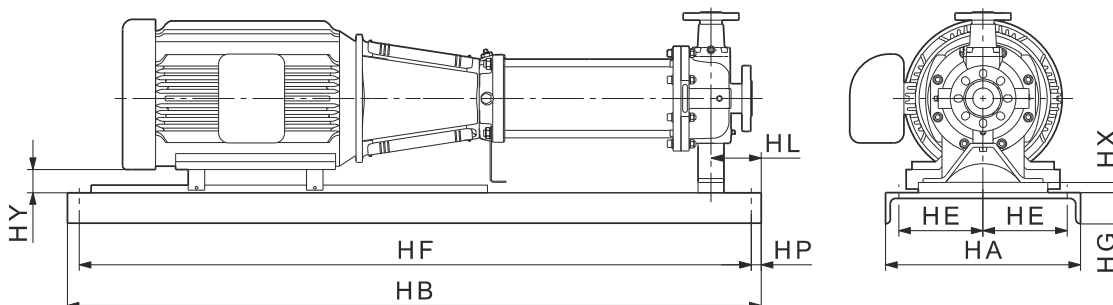

TM04 4641 1809

Baseplate selection

Baseplate number	NEMA frame	Flange size	CR 1s H to CR 20 H max. pump length (foot to rear motor hole) ¹⁾ [inches]	CR 32 to CR 90 H max. pump length (foot to rear motor hole) ¹⁾ [inches]
139	56T-182T	GA, GB, GC	27.5	23.5
148	213T-256T	GA, GB, GC	37	33
153	286T-364T	GA, GB, GC	42	38
245	56T-182T	G05-G70	34.5	30.5
252	213T	G05-G70	40.5	36.5
258	254T-286T	G05-G70	46.5	42.5
264	324T-364T	G05-G70	53	49
XLBP1 ²⁾	56T-182T	139, 245 BP	4)	4)
XLBP2 ²⁾	213T-254T	148, 252 BP	4)	4)
XLBP3 ²⁾	254T-364T	258, 264 BP	4)	4)
XLBP4 ²⁾	286T-364T	153 BP	4)	4)

Notes

1. If E4 - 4" > max. pump length, select XLBP (dimensions are in inches).
2. XLBP1 = longer version of 139 and 245 baseplate
XLBP2 = longer version of 145 and 252 baseplate
XLBP3 = longer version of 258 and 264 baseplate
XLBP4 = longer version of 153 baseplate
3. HF on long baseplate versions has bolt holes to use existing ANSI foundation bolts as well as additional bolt holes 1 1/4" from the end.
4. These long baseplates will accommodate all oversize pumps as listed.

Baseplate dimensions and weight

Base-plate number	NEMA	Flange size	HA	HB	HE	HF 3)	HG	Bolt hole diameter	HL	HP	HX NEMA	HY NEMA
139	56T	GA, GB, GC	12	39	4.5	36.5	3	0.75	4.5	1.25	0.75	2.50
	182T	GA, GB, GC	12	39	4.5	36.5	3	0.75	4.5	1.25	0.75	1.50
148	213T	GA, GB, GC	15	48	6	45.5	3.5	0.75	4.5	1.25	0.88	0.88
	256T	GA, GB, GC	15	48	6	45.5	3.5	0.75	4.5	1.25	1.88	0.88
153	286T	GA, GB, GC	18	53	7.5	50.5	4	0.75	4.5	1.25	3.63	1.88
	324T	GA, GB, GC	18	53	7.5	50.5	4	0.75	4.5	1.25	3.63	0.88
	364T	GA, GB, GC	18	53	7.5	50.5	4	0.75	4.5	1.25	5.06	1.31
245	56T	G05, G10, G50, G60, G70, G22, G33, G44	12	45	4.5	42.5	3	0.75	4.5	1.25	0.75	5.50
	56T	G20, G30, G40	12	45	4.5	42.5	3	0.75	4.5	1.25	0.75	7.25
	182T	G05, G10, G50, G60, G70, G22, G33, G44	12	45	4.5	42.5	3	0.75	4.5	1.25	0.75	4.50
	182T	G20, G30, G40	12	45	4.5	42.5	3	0.75	4.5	1.25	0.75	6.25
252	213T	G05, G10, G50, G60, G70, G22, G33, G44	15	52	6	49.5	3.5	0.75	4.5	1.25	0.88	3.88
	213T	G20, G30, G40	15	52	6	49.5	3.5	0.75	4.5	1.25	0.88	5.63
258	254T	G05, G10, G50, G60, G70, G22, G33, G44	18	58	7.5	55.5	4	1	4.5	1.25	0.69	2.69
	254T	G20, G30, G40	18	58	7.5	55.5	4	1	4.5	1.25	0.69	4.44
	286T	G05, G10, G50, G60, G70, G22, G33, G44	18	58	7.5	55.5	4	1	4.5	1.25	0.69	1.94
	286T	G20, G30, G40	18	58	7.5	55.5	4	1	4.5	1.25	0.69	3.69
264	324T	G05, G10, G50, G60, G70, G22, G33, G44	18	64	7.5	61.5	4	1	4.5	1.25	1.31	1.56
	324T	G20, G30, G40	18	64	7.5	61.5	4	1	4.5	1.25	1.31	3.31
	364T	G05, G10, G50, G60, G70, G22, G33, G44	18	64	7.5	61.5	4	1	4.5	1.25	2.31	2.56
	364T	G20, G30, G40	18	64	7.5	61.5	4	1	4.5	1.25	1.31	2.31
XLBP1	56 - 182T	139, 245 BP	12	59	These dimensions will be the same as the baseplate number they are replacing above.							
XLBP2	213 - 256T	148, 252 BP	15	70	The overall length is longer to accommodate longer pumps.							
XLBP3	254T - 364T	258, 264 BP	18	94.75	See notes 1 to 4 below.							
XLBP4	286T - 364T	153 BP	18	94.75								

All dimensions are in inches.

Notes

- If E4 - 4" > max. pump length, select XLBP (dimensions are in inches)
- XLBP1 = longer version of 139 and 245 baseplate
XLBP2 = longer version of 145 and 252 baseplate
XLBP3 = longer version of 258 and 264 baseplate
XLBP4 = longer version of 153 baseplate
- HF on long baseplate versions has bolt holes to use existing ANSI foundation bolts as well as additional bolt holes 1 1/4" from the end.
- These long baseplates will accommodate all oversize pumps as listed.

Baseplate and motor mounting kits

Baseplate	Kit description	Product number	Ship weight [lbs]
BP 139	Kit, BP139 56T GA/B/C	97534517	122
	Kit, BP139 182T GA/B/C	97534518	118
BP 148	Kit, BP148 213T GA/B/C	97534520	190
	Kit, BP148 254T GA/B/C	97534531	200
BP 153	Kit, BP153 284T GA/B/C	97534532	272
	Kit, BP153 324T GA/B/C	97534533	264
	Kit, BP153 364T GA/B/C	97534534	284
BP 245	Kit, BP245 56T G05/10/50/60/70/22/33/44	97534535	152
	Kit, BP245 182T G05/10/50/60/70/22/33/44	97534536	150
	Kit, BP245 56T G20/30/40	97534537	162
	Kit, BP245 182T G20/30/40	97534538	160
BP 252	Kit, BP252 213T G05/10/50/60/70/22/33/44	97534539	222
	Kit, BP252 213T G20/30/40	97534540	228
BP 258	Kit, BP258 254T G05/10/50/60/70/22/33/44	97534543	299
	Kit, BP258 284T G05/10/50/60/70/22/33/44	97534544	287
	Kit, BP258 254T G20/30/40	97534545	307
BP 264	Kit, BP258 284T G20/30/40	97534546	307
	Kit, BP264 324T G05/10/50/60/70/22/33/44	97534548	332
	Kit, BP258 364T G05/10/50/60/70/22/33/44	97534550	356
XLBP1	Kit, BP258 324T G20/30/40	97534571	332
	Kit, BP258 364T G20/30/40	97534572	334
XLBP2	Kit, BP139 56T GA/B/C	97534573	167
	Kit, BP139 182T GA/B/C	97534574	163
	Kit, BP245 56T G05/10/50/60/70/22/33/44	97534575	180
	Kit, BP245 182T G05/10/50/60/70/22/33/44	97534576	178
	Kit, BP245 56T G20/30/40	97534577	190
	Kit, BP245 182T G20/30/40	97534578	188
	Kit, BP148 213T GA/B/C	97573875	262
	Kit, BP148/252 254T GA/B/C	97534579	275
	Kit, BP252 213T G05/10/50/60/70/22/33/44	97573873	278
	Kit, BP252 213T G20/30/40	97573874	284
XLBP3	Kit, BP258/264 254T G05/10/50/60/70/22/33/44	97573876	461
	Kit, BP258/264 284T G05/10/50/60/70/22/33/44	97573877	449
	Kit, BP258/264 254T G20/30/40	97573878	469
	Kit, BP258/264 284T G20/30/40	97573879	469
	Kit, BP258/264 324T G05/10/50/60/70/22/33/44	97534580	461
	Kit, BP258/264 364T G05/10/50/60/70/22/33/44	97534591	470
	Kit, BP258/264 324T G20/30/40	97534592	476
XLBP4	Kit, BP258/264 364T G20/30/40	97534593	463
	Kit, BP153 284T GA/B/C	97534594	453
	Kit, BP153 324T GA/B/C	97534595	445
	Kit, BP153 364T GA/B/C	97534596	465

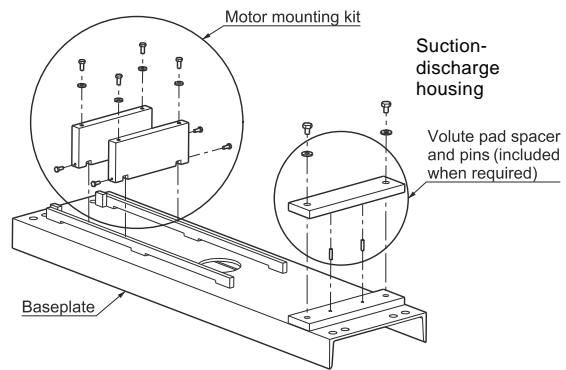

TM04 4805 2108

Pipework connection

Various sets of counter flanges are available for pipework connection.

Counter flanges for CR, CRE

A set consists of two counter flanges, two gaskets, bolts and nuts.

Pump type	Description	Press. class	Pipework connection (suction and discharge)	Product number
GA	Threaded	ANSI 125 lb.	1.5" x 1" NPT	97642565
G05			2" x 1" NPT	97642567
GB, G50, G20			3" x 1.5" NPT	97642571
GC, G10, G60, G30			3" x 2" NPT	97642574
G70, G40			4" x 3" NPT	97642576
G22			2" x 2" NPT	97642568
G33			3" x 3" NPT	559601
G44			4" x 4" NPT	579801
GA			Threaded	ANSI 250 lb.
G05	2" x 1" NPT	96967595		
GB, G50, G20	3" x 1.5" NPT	97658571		
GC, G10, G60, G30	3" x 2" NPT	97658572		
G70, G40	4" x 3" NPT	97658574		
G22	2" x 2" NPT	335021		
G33	3" x 3" NPT	97658573		
G44	4" x 4" NPT	360028		

The 3" and 4" 125 lb. flanges and the 4" 250 flanges on the pumps are standard through-hole ANSI flanges. All other CR-H pump flanges are threaded and will require shorter than standard bolts. Recommended bolt sizes are shown below.

Press. class	Flange size	Qty. bolts	Required bolts	Standard hardware
125	1"	4	1/2-13 x 2	
	1.5"	4	1/2-13 x 2	
	2"	4	5/8-11 x 2.5	
	3"	4	5/8-11 x 3	●
	4"	8	5/8-11 x 3	●
250	1"	4	5/8-11 x 2.25	
	1.5"	4	3/4-10 x 2.5	
	2"	8	5/8x11 x 2.5	
	3"	8	3/4-10 x 3.25	
	4"	8	3/4-10 x 3.75	●

Potentiometer for CRE-H

Potentiometer for setpoint setting and start/stop of the CRE-H pump.

Product	Product number
External potentiometer with cabinet for wall mounting	625468

G10-LON interface for CRE-H

The G10-LON interface is used in connection with data transmission between a locally operating network (LON) and electronically controlled Grundfos pumps applying the Grundfos bus-protocol GENIbus.

Product	Product number
G10-LON interface	00605726

Remote control, R100

R100 is used for wireless communication with the CRE-H pump. The communication takes place by means of infrared light.

Product	Product number
R100	625333

EMC filter for CRE-H

The EMC filter is required for installation of 15 to 30 hp E-pumps in residential areas.

Product	Product number
EMC filter (11 kW)	96478309
EMC filter (15 kW)	
EMC filter (18.5 kW)	
EMC filter (22 kW)	

Sensors for CRE-H

Accessory	Measuring range	Product number
Pressure sensor • Connection: 1/4" NPT Includes a 6 ft cable with removable potted plug in addition to a standard plug for remote mounting.	0-87 psi (0-6 bar)	91136169
	0-145 psi (0-10 bar)	91136170
	0-232 psi (0-16 bar)	91136171
	0-362 psi (0-25 bar)	91136172
	0-580 psi (0-4 bar)	91136173
	0-200 psi	91120777

Note: For accurate pressure readings, the sensor must be installed in the discharge piping and not in the CRE-H volute.

Gauges for CR-H, CRE-H

Accessory	Measuring range [psi (bar)]	Product number
Liquid-filled pressure gauge • AISI 304/copper	30" Hg - 30 psi (2 bar)	91123566
	0-60 (0-4)	00ID8562
	0-100 ps(0-4)	00ID8563
	0-100 (0-4)	00ID8564
	0-200 (0-14)	00ID8565
	0-300 psi (0-21)	00ID8566
	0-400 (0-28)	00ID8567
	0-600 (0-41)	00ID8568
	30" Hg - 30 (2)	91130835
	0-60 (0-4)	00ID8569
Liquid-filled pressure gauge • AISI 316	0-100 (0-4)	00ID8570
	0-160 (0-11)	00ID8571
	0-200 (0-14)	00ID8572
	0-300 (0-21)	00ID8573
	0-400 (0-28)	00ID8574
	0-600 (0-41)	00ID8575
	0-200 (0-14)	00ID8576

Note: For accurate pressure readings, the gauges must be installed in the suction and discharge piping and not in the CR(E)-H volute.

MP 204 motor protector



TM03 1471 2205

Fig. 31 MP 204

The MP 204 is an electronic motor protector and data collecting unit. Apart from protecting the motor, it can also send information to a control unit via GENIbus, like for instance:

- trip
- warning
- energy consumption
- input power
- motor temperature.

The MP 204 protects the motor primarily by measuring the motor current by means of a true RMS measurement.

The pump is protected secondarily by measuring the temperature with a Tempcon sensor, a Pt100/Pt1000 sensor and a PTC sensor/thermal switch.

The MP 204 is designed for single- and three-phase motors.

Note: The MP 204 must not be used together with frequency converters.

Features

- Phase-sequence monitoring
- indication of current or temperature
- input for PTC sensor/thermal switch
- indication of temperature in ° C or ° F
- 4-digit, 7-segment display
- setting and status reading with the Grundfos R100

remote control

- setting and status reading via the Grundfos GENIbus fieldbus.

Tripping conditions

- Overload
- underload (dry running)
- temperature
- missing phase
- phase sequence
- overvoltage
- undervoltage
- power factor ($\cos \varphi$)
- current unbalance.

Warnings

- Overload
- underload
- temperature
- overvoltage
- undervoltage
- power factor ($\cos \varphi$)
- run capacitor (single-phase operation)
- starting capacitor (single-phase operation)
- loss of communication in network
- harmonic distortion.

Learning function

- Phase sequence (three-phase operation)
- run capacitor (single-phase operation)
- starting capacitor (single-phase operation)
- identification and measurement of Pt100/Pt1000 sensor circuit.

Product number

Description	Product number
MP 204 motor protection	96079927

Submittal data

Client information

Project title:	Client name:
Reference number:	Client number:
Client contact:	Client phone number: ()

Location information

For:	Unit:		
Site:	Service:		
Address:	City:	State:	Zip code:

Application information

Operating conditions				Pumped liquid			
Max.	Norm.	Min.		Liquid type:	Rated	Max.	Norm.
Flow (gpm)				Liquid temperature (°F)			
Suction pressure (psig)				at designated temperature			
Discharge pressure (psig)				Specific gravity			
Differential head (ft)				Vapour pressure (psia)			
Hydraulic power (hp) at designated capacity				Viscosity (cp)			
NPSH available (ft)				Liquid ph:		Chlorides (ppm):	
				Hazardous:		CorrosioneErosion caused by:	
				Flammable:			
				Other:			

Service

Continuous	
Intermittent (starts/day):	

Pump information

Model Information from type key and codes:	----> (Example: CR 5-10 H-GA-A-E-HQQE)
Quantity required:	
Minimum required flow:	NPSH required at duty point:

Product guide additional information pages

Materials page number:	Performance curve page number:
Technical data page number:	Motor data page number:

Motor information

Hp:	Phases:	Voltage:	Enclosure class:
-----	---------	----------	------------------

Custom-built pump information (optional):

Additional Information

CR-H, CRE-H

Horizontal, non-self-priming, multistage, end suction, centrifugal pump for installation in pipe systems and mounting on a foundation.

The pump has the following characteristics:

- impellers and intermediate chambers are made of AISI _____ stainless steel
 - pump head and volute are made of _____
 - power transmission is via cast iron split coupling.
 - pipework connection is via _____
- The motor is a _____ -phase AC motor.

Technical

Rated flow: _____ gpm
 Rated head: _____ ft
 Minimum liquid temperature: _____ °F
 Maximum liquid temperature: _____ °F
 Type of shaft seal: _____

Materials

Material, pump housing: _____
 Material, shaft: AISI _____ stainless steel
 Material, impeller: AISI _____ stainless steel
 Material, sleeve: AISI _____ stainless steel
 Material, seal metal: AISI _____ stainless steel
 - seal face: _____
 - seal face: _____
 - seal elastomer: _____

Installation

Maximum ambient temperature: _____ °F
 Max. pressure at stated temp.: _____ psi / °F
 Standard, pipe connection: _____
 Size, pipe connection: _____
 Rated pressure, pipe connection: _____ psi
 Frame size for motor: _____ NEMA

Electrical data

Motor type: _____
 Rated power (P2): _____ hp
 Frequency: _____ Hz
 Rated voltage: _____ V
 Rated current: _____ A
 Service factor: _____
 Starting current: _____ A
 Rated speed: _____ rpm
 Full load motor efficiency: _____ %
 Insulation class: _____

Additional

Gross weight: _____ lbs.
 Shipping volume: _____ ft³
 Model: _____

WebCAPS

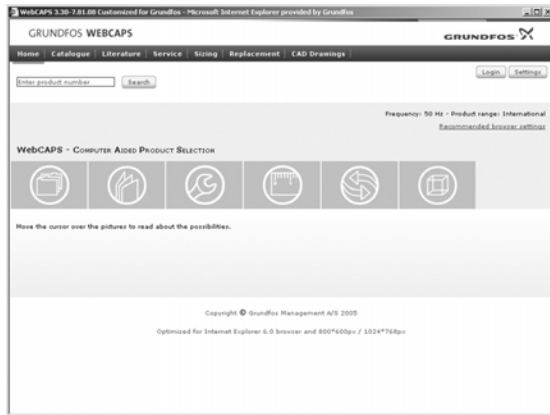

WebCAPS is a **Web-based Computer Aided Product Selection** program available on www.grundfos.com.

WebCAPS contains detailed information on more than 185,000 Grundfos products in more than 20 languages.

In WebCAPS, all information is divided into 6 sections:

- Catalog
- Literature
- Service
- Sizing
- Replacement
- CAD drawings.

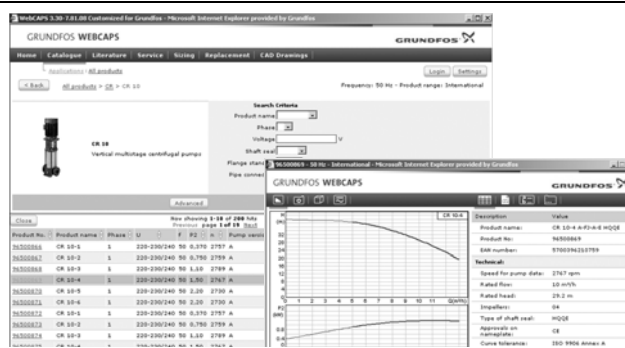

Catalog

This section is based on fields of application and pump types, and contains

- technical data
- curves (QH, Eta, P1, P2, etc) which can be adapted to the density and viscosity of the pumped liquid and show the number of pumps in operation
- product photos
- dimensional drawings
- wiring diagrams
- quotation texts, etc.

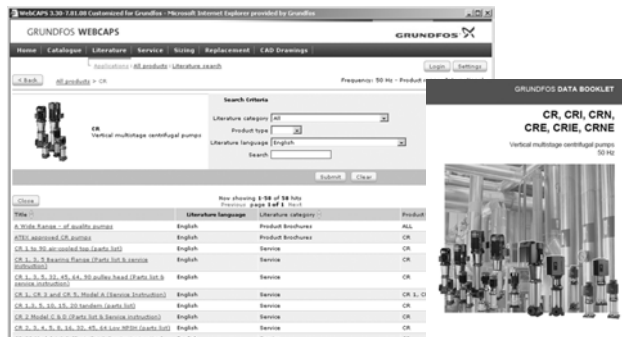

Literature

In this section you can access all the latest documents of a given pump, such as

- product guides
- installation and operating instructions
- service documentation, such as Service kit catalog and Service kit instructions
- quick guides
- product brochures, etc.



Service

This section contains an easy-to-use interactive service catalog. Here you can find and identify service parts of both existing and discontinued Grundfos pumps.

Furthermore, this section contains service videos showing you how to replace service parts.



Sizing

This section is based on different fields of application and installation examples, and gives easy step-by-step instructions in how to

- select the most suitable and efficient pump for your installation
- carry out advanced calculations based on energy consumption, payback periods, load profiles, life cycle costs, etc.
- analyse your selected pump via the built-in life cycle cost tool
- determine the flow velocity in wastewater applications, etc.



Replacement

In this section you find a guide to selecting and comparing replacement data of an installed pump in order to replace the pump with a more efficient Grundfos pump. The section contains replacement data of a wide range of pumps produced by other manufacturers than Grundfos.

Based on an easy step-by-step guide, you can compare Grundfos pumps with the one you have installed on your site. When you have specified the installed pump, the guide will suggest a number of Grundfos pumps which can improve both comfort and efficiency.

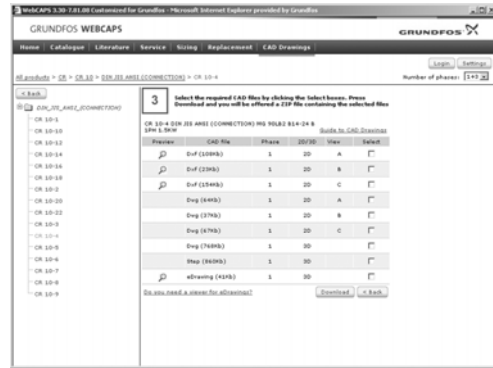

CAD drawings

In this section it is possible to download 2-dimensional (2D) and 3-dimensional (3D) CAD drawings of most Grundfos pumps.

These formats are available in WebCAPS:

2-dimensional drawings:

- .dxf, wireframe drawings
- .dwg, wireframe drawings.

3-dimensional drawings:

- .dwg, wireframe drawings (without surfaces)
- .stp, solid drawings (with surfaces)
- .eprt, E-drawings.

WinCAPS



Fig. 32 WinCAPS CD-ROM

WinCAPS is a **Windows-based Computer Aided Product Selection** program containing detailed information on more than 185,000 Grundfos products in more than 20 languages.

The program contains the same features and functions as WebCAPS, but is an ideal solution if no Internet connection is available.

WinCAPS is available on CD-ROM and updated once a year.

Subject to alterations.

L-CRH-PG-01 Rev. 0310

US

© 2009, 2010 Grundfos Pumps Corp.

The name Grundfos, the Grundfos logo, and the payoff Be-Think-Innovate are registered trademarks owned by Grundfos Management A/S or Grundfos A/S, Denmark. All rights reserved worldwide.

GRUNDFOS Pumps Corporation
17100 West 118th Terrace
Olathe, Kansas 66061
Phone: +1-913-227-3400
Telefax: +1-913-227-3500

GRUNDFOS Canada Inc.
2941 Brighton Road
Oakville, Ontario L6H 6C9 Canada
Phone: +1-905 829 9533
Telefax: +1-905 829 9512

Bombas GRUNDFOS de Mexico S.A. de C.V.
Boulevard TLC No. 15
Parque Industrial Stiva Aeropuerto
Apodaca, N.L. Mexico 66600
Phone: +52-81-8144 4000
Telefax: +52-81-8144 4010

www.grundfos.com

GRUNDFOS 