

JPC COST-EFFICIENT WATER TRANSFER BUILT ON PROVEN QUALITY



The Grundfos JPC is a self-priming, single-stage jet-pump, covering a wide variety of domestic water transfer and supply jobs. The pump is especially ideal wherever self-priming operation is necessary as it features a built-in ejector with guide vanes for

optimum self-priming properties. The body and internal components of the JPC are made of technopolymer to make the pump resistant to corrosion. Installation of the JPC is simple plug-and-pump.

BENEFITS AND TECHNICAL FEATURES

Self-priming water transfer pump

Featuring a suction-lift up to 8m, the JPC pump is ideal for transferring water from wells or ground tanks in a large variety of installations.

Robust design

The lightweight materials ensure excellent corrosion resistance to offer a very robust pump.

Thermal overload protection

JPC is effectively protected against any accidental overload by means of built-in thermal and current protection. This means that no additional motor protection is required.

Stable operation

The pump ensures stable operation with excellent suction capacity even when there are air bubbles and small sandy impurities in the water.

PERFORMANCE RANGE

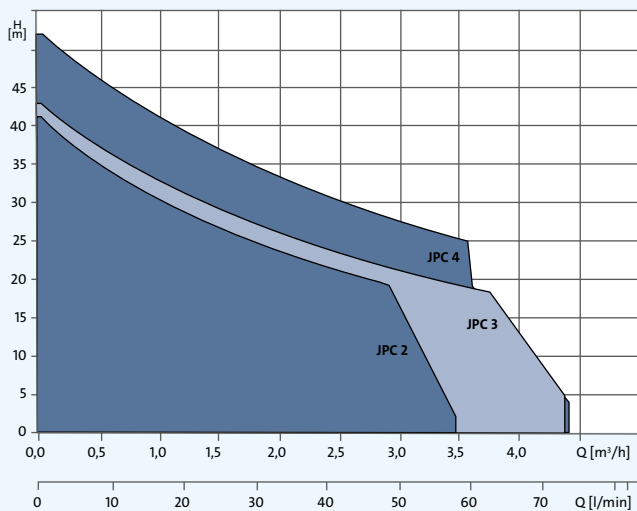

APPLICATION – WATER TRANSFER

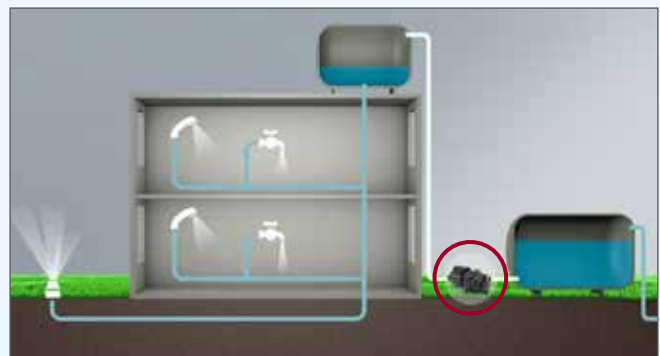

ACCESSORIES FOR BOOSTER SOLUTIONS

- Pressure Switch (PS)
- Pressure Manager 1 (PM1)
- Pressure Manager 2 (PM2)
- Pressure tank (PT)

TECHNICAL DATA

Mains voltage	1 x 115 V, 60 Hz 1 x 220-240 V, 50/60 Hz
Enclosure class	IP44
Insulation class	F
Start/stop frequency	Max. 20 per hour

Pump type	P1	
	HP	KW
JPC 2	1.0	0.72
JPC 3	1.15	0.85
JPC 4	1.5	1.1

DIMENSIONS

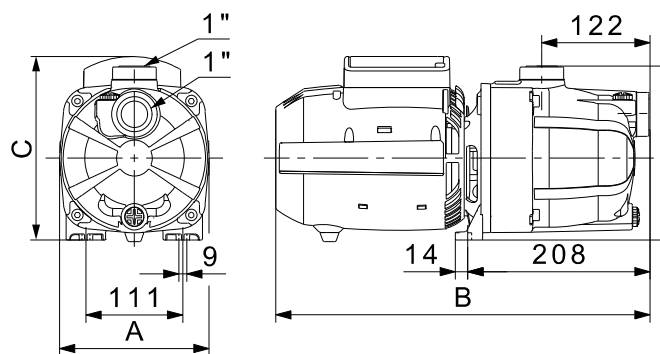

Pump type	Dimensions [mm]			Weight [kg]
	A	B	C	
JPC 2	171	410	200	8.0
JPC 3	171	410	200	8.3
JPC 4	171	430	210	10.3

OPERATING CONDITIONS

System pressure	Max. 6 bar
Suction lift	Max: 8m, including suction pipe pressure loss at a liquid temperature of +20 °C
Liquid temperature	0 °C to +35 °C
Ambient temperature	Max. 40 °C
Relative air humidity	Max. 95 %